

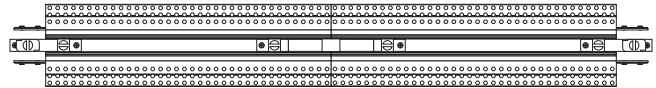

1718 W. Fullerton Chicago, IL 60614
 Ph: 773.770.1195 • Fax: 773.935.5613
 www.PureEdgeLighting.com • info@PureEdgeLighting.com
 © 2016 PureEdge Lighting. All Rights Reserved.

Installation Instructions for TruTrack Magnetic Two Circuit, Recessed 24VDC - Center Power Feed

TR24M-2C-CP



IMPORTANT INFORMATION

- Read all of these installation instructions before installing the track system and refer to them when additions to or changes in the track configuration are made.
- **DO NOT** install this track in damp or wet locations.
- **DO NOT** install any part of a track system less than 5 feet above the floor. **DO NOT** install any luminaire assembly closer than 6 inches from any curtain or similar combustible material.
- Disconnect the electrical power before adding to or changing the configuration of the track.
- Only install luminaires identified with Pure Edge Lighting track systems. **DO NOT** attempt to connect any power tools and equipments to the track system.
- **DO NOT** overload each branch of track connected to the Track Power Feed Connectors resulting in a risk of fire.
- The system is "ETL" listed for USA and Canada only when all the products used are supplied by Pure Edge Lighting.
- **DO NOT** field modify this component.

GENERAL INFORMATION

- This instruction shows a typical installation.
- Before beginning any electrical work, ensure that the power to the electrical box is **OFF**.
- This product must be installed by a qualified electrician and in accordance with local electrical codes.



Scan with your mobile device for more information or visit www.pureedgelighting.com/pureedge/products/trustrack_magnetic.php?bc=Products|Recessed|Recessed%20Track

SAVE THESE INSTRUCTIONS!

Section One: Install the Junction Box

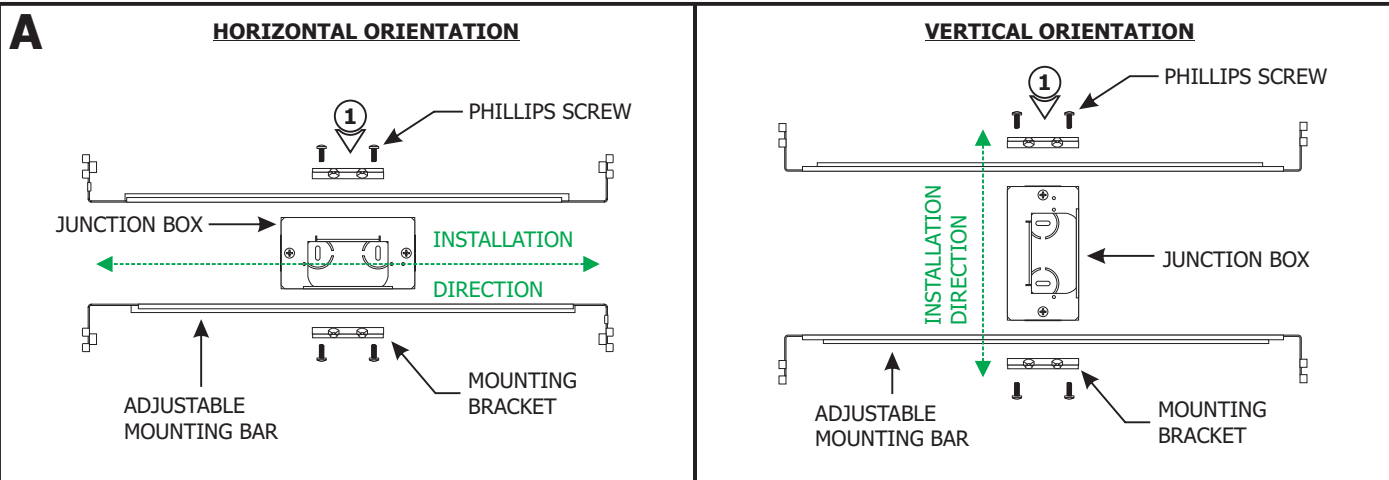

1: Mount each adjustable mounting bar to one side of the junction box and secure them with the mounting brackets and Phillips screws provided.

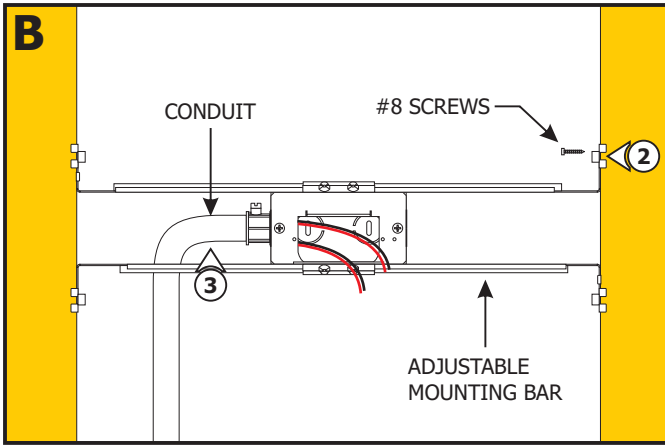

NOTE: Adjustable mounting bars mount to studs that are spaced 15" to 24" apart. If the span needs to be shorter than 15", then break the bar arms from dedicated lines.

2: Place the adjustable mounting bar tabs against the ceiling joists. Secure the adjustable bars to the joists with the #8 screws.

3: Run the Class 2 24VDC low voltage wires coming from the remote power supplies to the junction box. Only install conduit if required by local electrical codes.

NOTE: Only use 0-10V and Uni power supplies with this product. See the wiring diagram provided with the power supply instructions.

Section Two: Install Center Power Feed

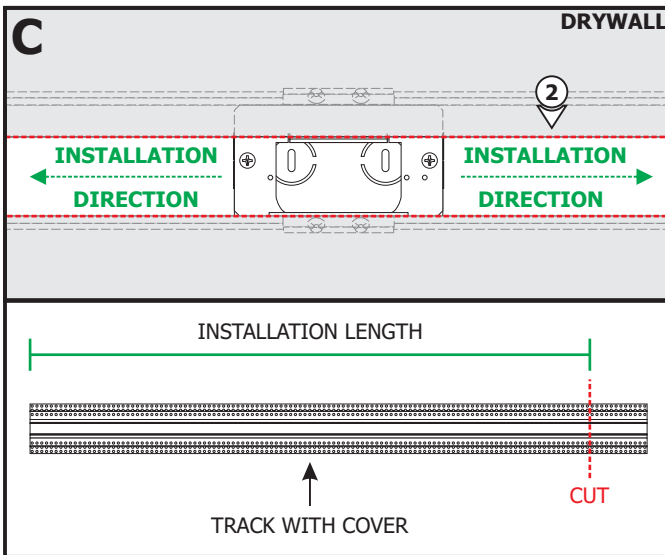

1: Cut a section of drywall to expose the junction box area. Install the drywall.

2: Mark and cut out the area where the installation will be located using the junction box opening as a guide.

NOTE: Refer to the TruTrack Recessed Channel instructions to measure and cut the track and cover before continuing.

NOTE: Ensure both ends of the connector are supported with either a joist or mounting strap. To install the track without standard-spaced joists, install perforated mounting straps.

- 3:** For each mounting strap (**MBAR**), thread a drywall screw into the perforated material. Use the screw to hold and place the mounting strap behind the drywall, and then rotate it in place.
- 4:** Secure the mounting straps to the drywall on each side of the junction box using two drywall screws. Mark the location of the mounting strap on the drywall.

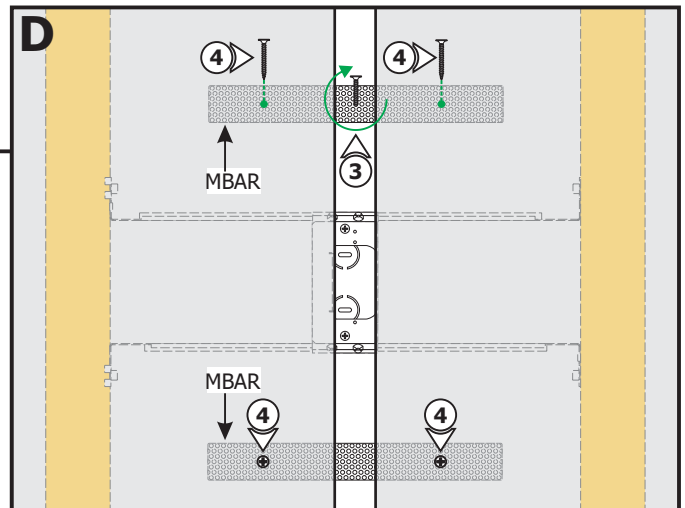

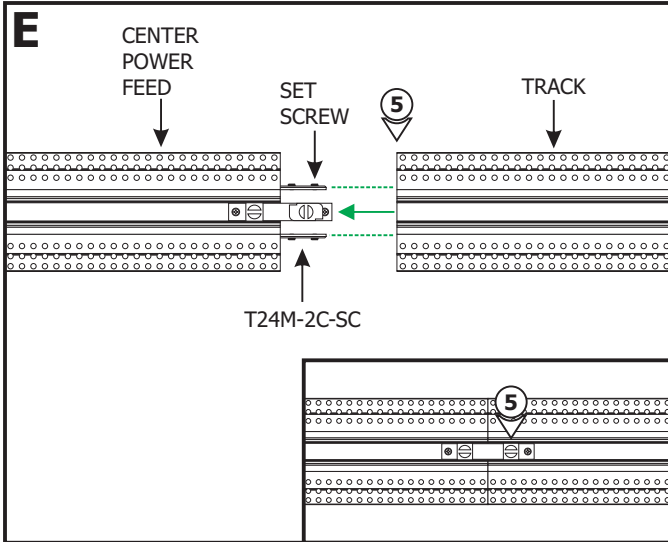

5: Align and slide tracks over the straight connectors (**T24M-2C-SC**) on the ends of the Center Power Feed. Tighten the set screws using an Allen wrench and the slotted screw on the straight connector using a flat-head screw driver.

6: Place the assembled channel in the drywall cutout. Using the marked joist and mounting strap locations on the drywall, drill and countersink the channel using the provided square drill with countersink bit.

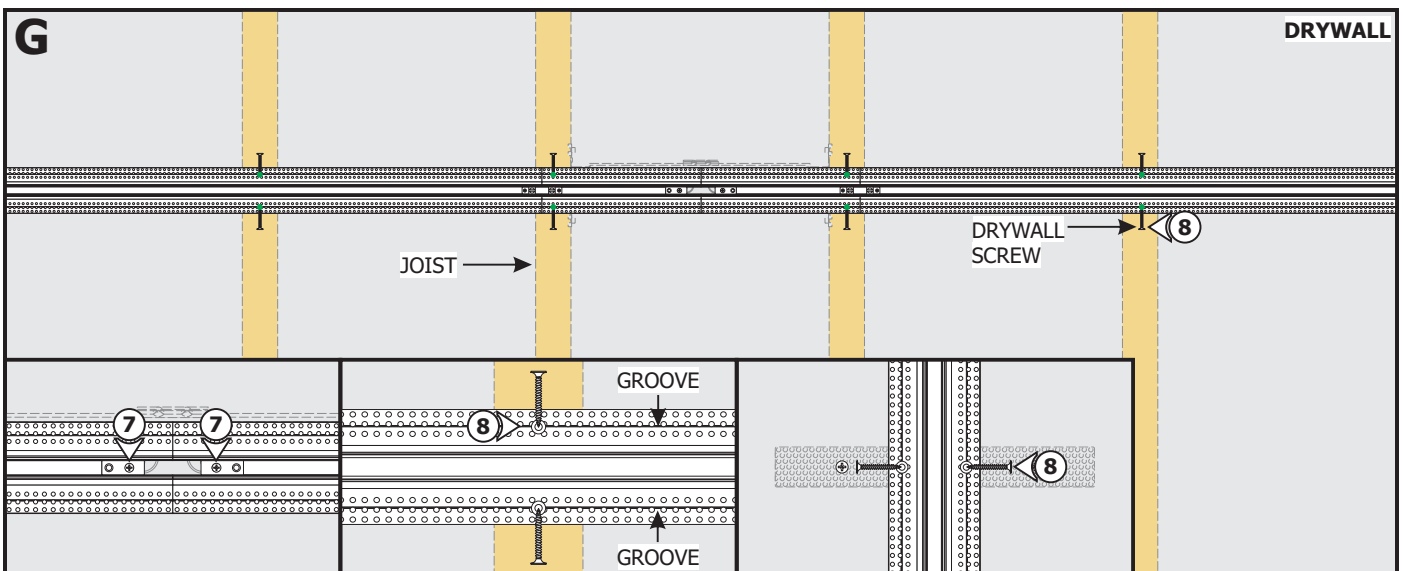
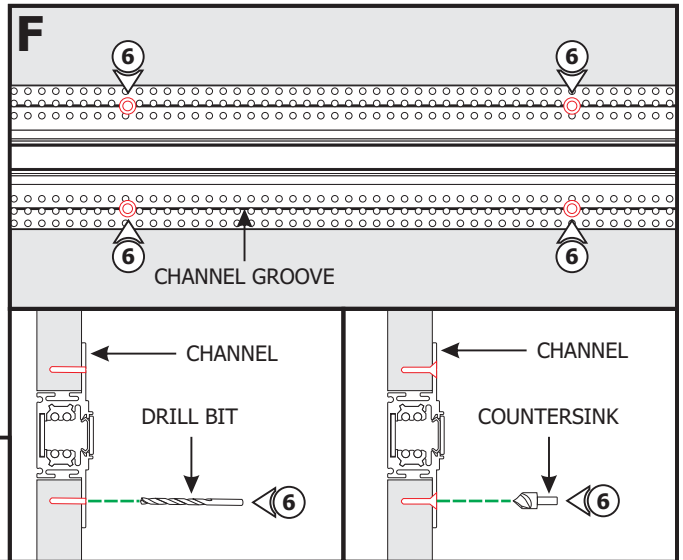

7: Secure the Center Power Feed to the junction box with the two Phillips screws.

8: Properly secure the channel to the marked joists and mounting straps using drywall screws (**DO NOT over tighten**). Ensure all screw heads are flush with the channel surface.

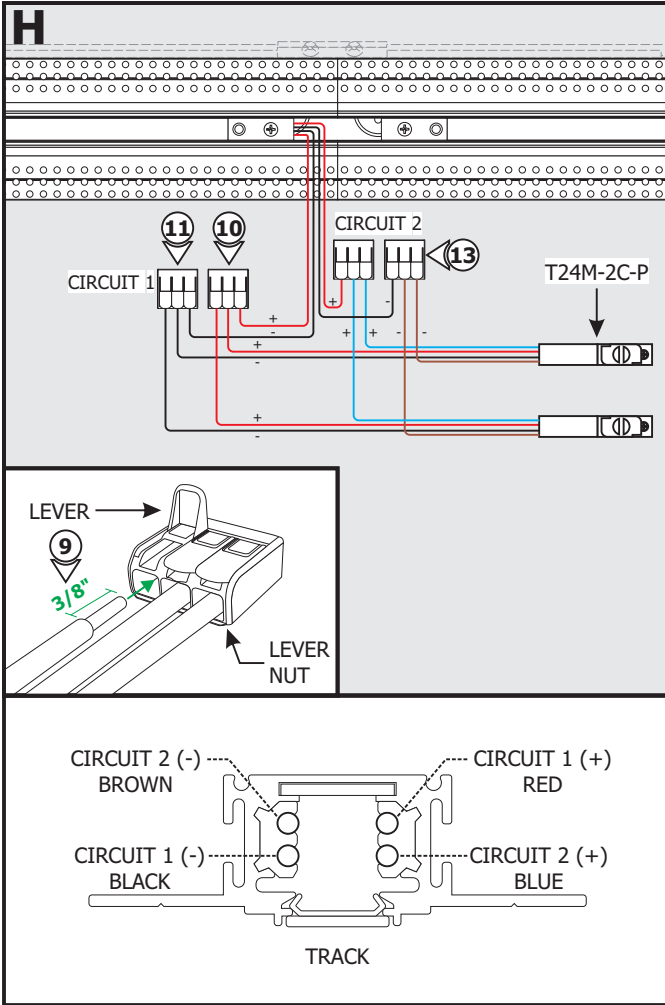

NOTE: Follow steps 9 through 15 for connecting the Center Power Feed as a single two circuit center feed. Omit steps 16 through 23 on page 5.

9: Strip 3/8" off of the Power Feed Connector (T24M-2C-P) wires and the low voltage power supply wires.

10: On the lever nut that the Circuit 1 POSITIVE red Power Feed Connector wires are connected, pull up the available lever and insert the low voltage +24VDC power supply wire. Push the lever down to connect and lock into place.

11: On the lever nut that the Circuit 1 NEGATIVE black Power Feed Connector wires are connected, pull up the available lever and insert the low voltage -24VDC power supply wire. Push the lever down to connect and lock into place.

12: Lightly tug on the wires to ensure they are secured in place.

13: Repeat steps 9 through 12 to connect the Circuit 2 POSITIVE blue wires and NEGATIVE brown wires to the +24VDC wire and -24VDC wire of the other power supply respectively.

14: Place the lever nut connections inside the junction box.

15: Place the Power Feed Connectors inside the Center Power Feed and tighten the slotted screw with a flat-head screw driver to secure in place.

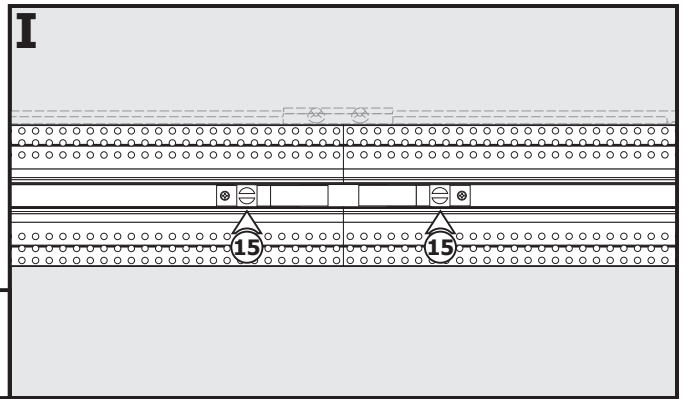

CAUTION: Test the circuits using a track head before plastering.

NOTE: Refer to the TruTrack Recessed Channel instructions to plaster and complete the installation.

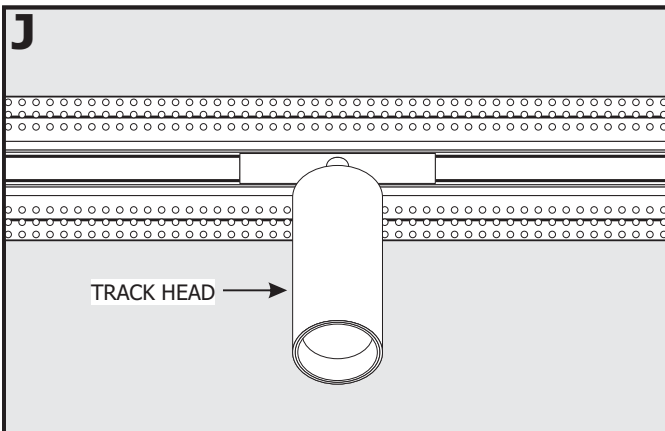

General Wiring Diagram for Single Two Circuit Center Feed

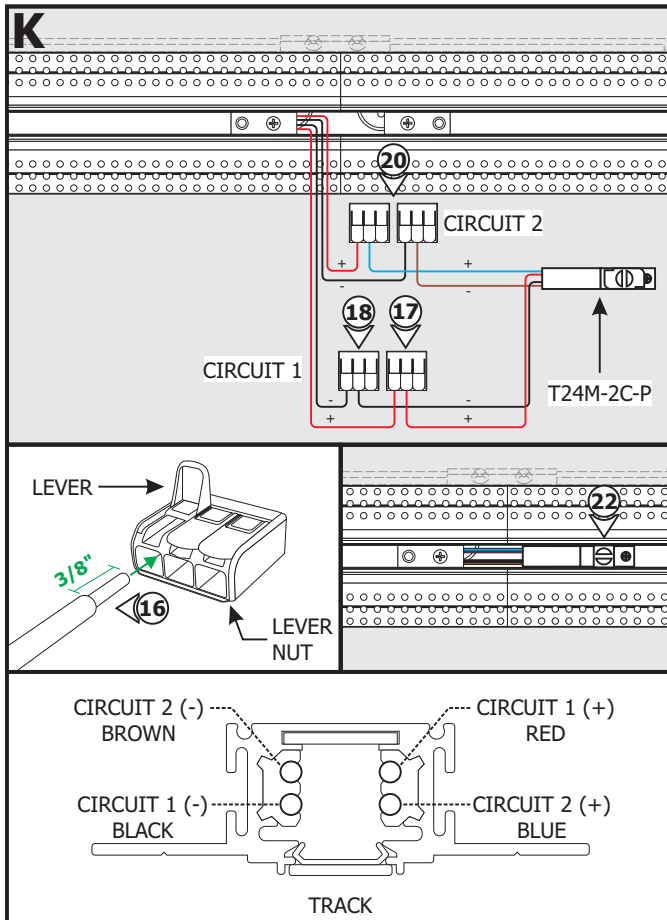
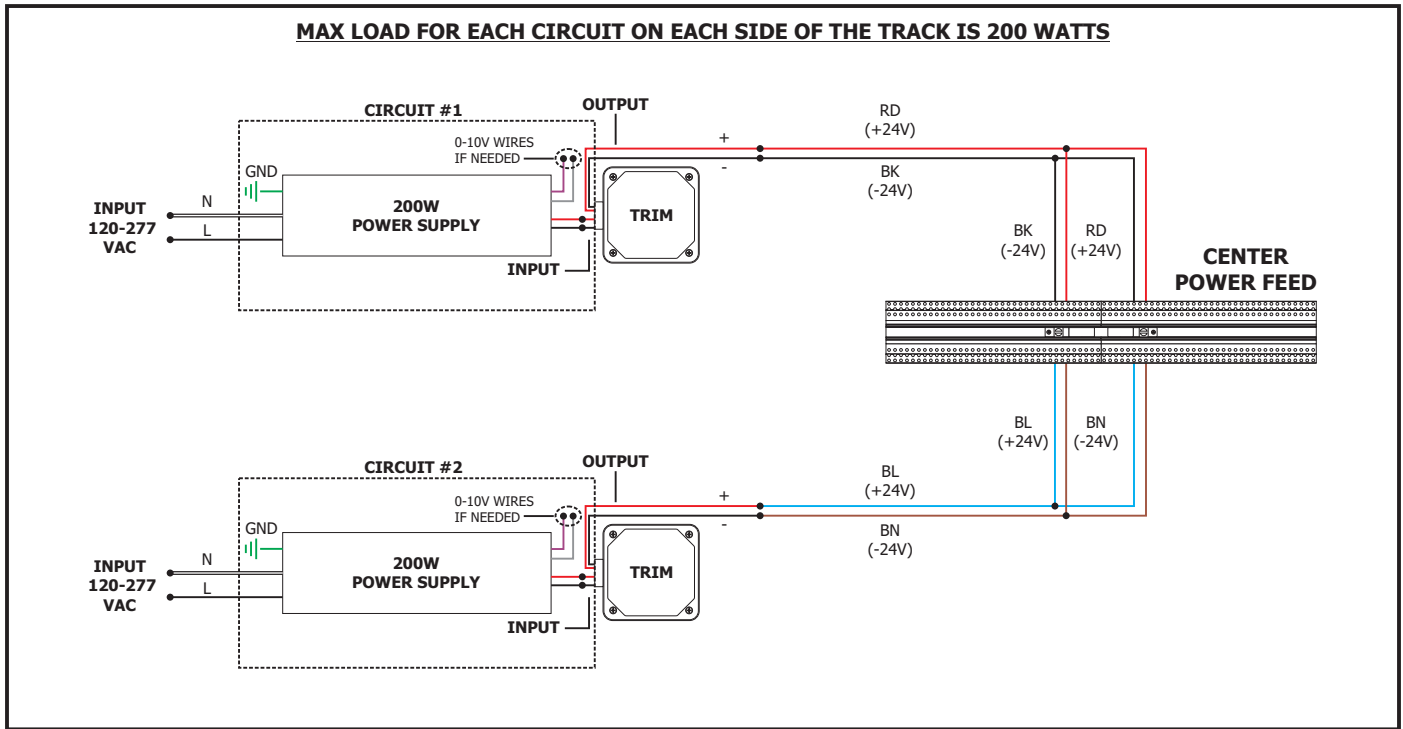

NOTE: Follow steps 16 through 23 for connecting the Center Power Feed as a dual two circuit center feed.

- 16:** Strip 3/8" off of the Power Feed Connector (T24M-2C-P) wires and the low voltage power supply wires.
- 17:** On the lever nut that the Circuit 1 POSITIVE red Power Feed Connector wire is connected, pull up the available lever and insert the low voltage +24VDC wire from one power supply. Push the lever down to connect and lock into place.
- 18:** On the lever nut that the Circuit 1 NEGATIVE black wire from the same Power Feed Connector is connected, pull up the available lever and insert the low voltage -24VDC wire from the same power supply. Push the lever down to connect and lock into place.
- 19:** Lightly tug on the wires to ensure they are secured in place.
- 20:** Repeat steps 16 through 19 to connect the Circuit 2 POSITIVE blue wire and NEGATIVE brown wire from the same Power Feed Connector to the +24VDC wire and -24VDC wire of the other power supply respectively.
- 21:** Place the lever nut connections inside the junction box.
- 22:** Place the Power Feed Connector inside the Center Power Feed and tighten the slotted screw with a flat-head screw driver to secure in place.

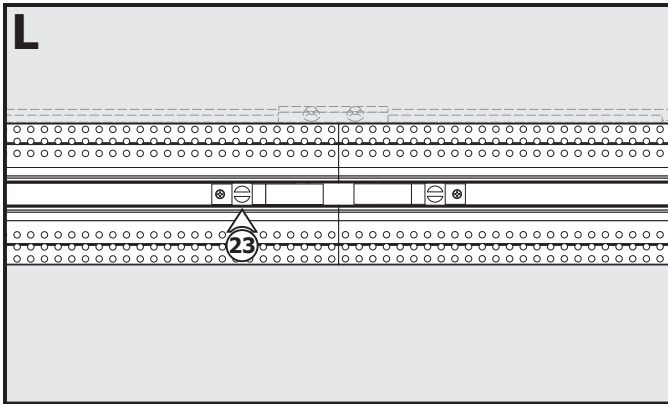

23: Repeat steps 16 through 22 to connect the second Power Feed Connector to two other power supplies.

CAUTION: Test the circuits using a track head before plastering.

NOTE: Refer to the TruTrack Recessed Channel instructions to plaster and complete the installation.

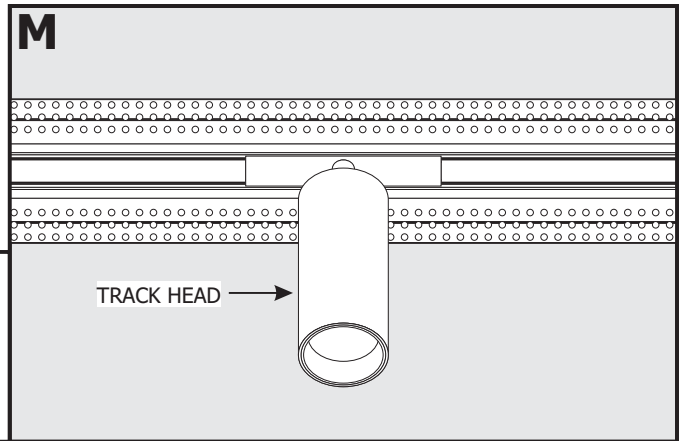

General Wiring Diagram for Dual Two Circuit Center Feed

