

## Installation Instructions for **Fast Jack Crossroads Pendant**

### IMPORTANT SAFETY INSTRUCTIONS

To reduce the risk of fire, electrical shock, exposure to excessive UV radiation, or injury to persons:

- Use this fixture indoors only.
- Do not look directly at the lamp while the fixture is on.
- **RISK OF FIRE:** Use only the type of lamp and maximum wattage indicated in this instruction manual.
- Never cover the halogen lamp with anything other than a lamp shield provided by Edge Lighting and never place flammable material close to the fixture.
- Never turn the fixture on and off by connecting and disconnecting the halogen lamp.
- Do not touch the fixture head, shade or lamp shield while the fixture is on. These surfaces may be **VERY HOT**.
- Do not touch lamp at anytime. Use a soft cloth instead as oil from skin may damage lamp.
- It is normal for a new halogen lamp to produce minor smoke when first turned on.
- Do not operate the luminaire with a missing or damaged shield.
- Turn power off and allow to cool before replacing lamp.

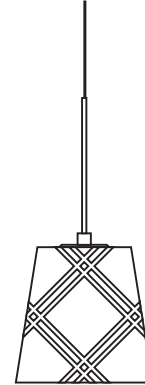

### IMPORTANT INFORMATION

- This product is ETL listed for indoor dry locations and approved to be used at any height above the finished floor.

**SAVE THESE INSTRUCTIONS!**

## Install the Lamp

**A**

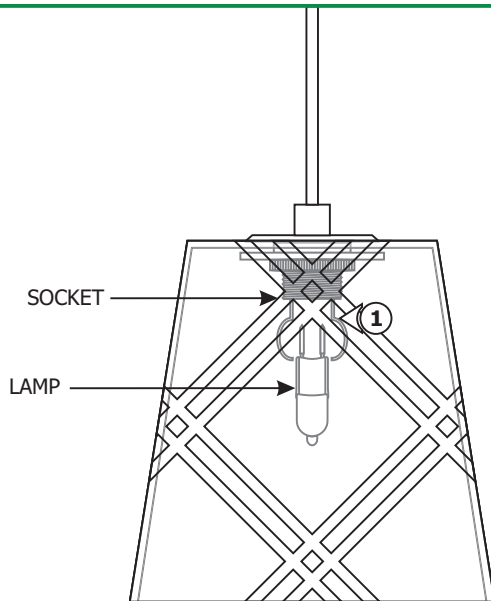

**CAUTION:** To reduce risk of a burn or electrical shock during lamping, disconnect the power to the fixture.

Use **MAX 50** Watt, Type Bi-Pin Halogen Lamp.



**NOTE:** Use a soft cloth and fingers to install the lamp.

**1:** Push the lamp pins completely into the socket holes.

**B**

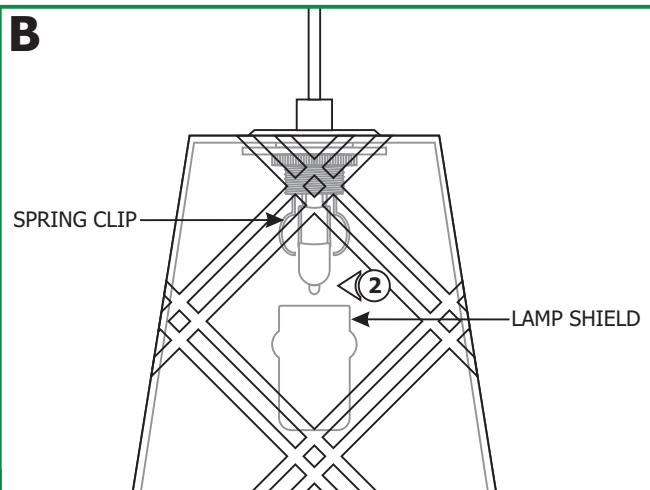

**2:** Push the lamp shield onto the spring clips.

# Adjust the Fixture Height

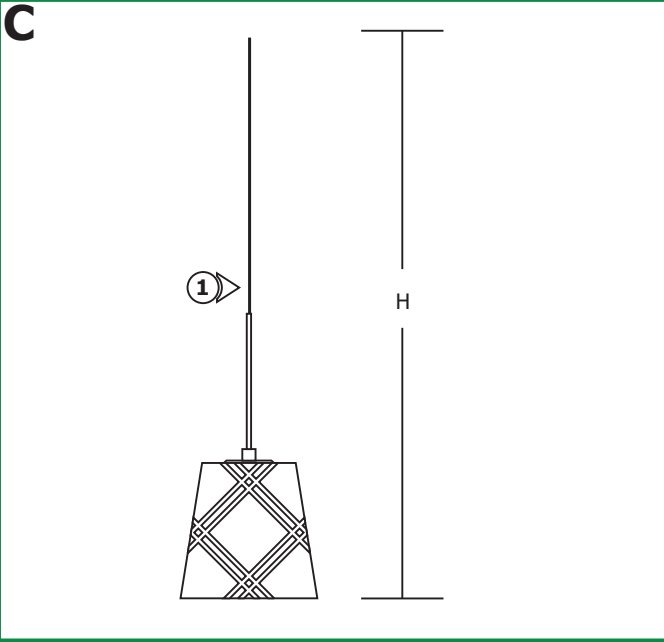

**1:** Cut the coaxial cable to the desired height (H) with a sharp cutter. The overall fixture height is measured from the bottom of the glass shade to the end of the coaxial cable.

**2:** Loosen the M4 set screw on base of the coaxial fixture connector with the 2mm Allen wrench provided. **Do not remove this set screw.**

**3:** Remove the M3 set screw on tip of the connector with the 1.5mm Allen wrench provided.

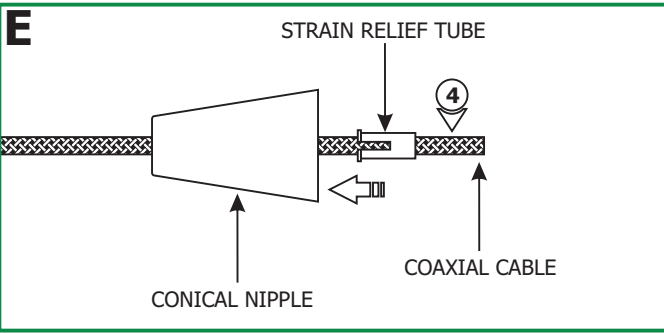
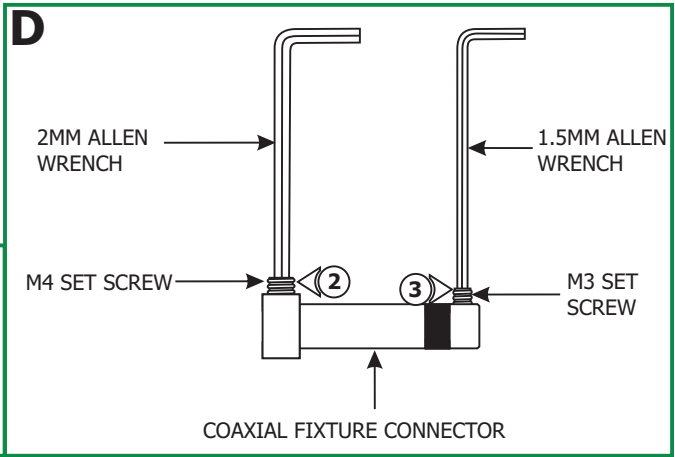

**4:** Feed the coaxial cable through the conical nipple and flared side of the strain relief tube. Slide the conical nipple and strain relief tube down the coaxial cable.

**5:** Feed the coaxial cable into the coaxial fixture connector. The coaxial cable will come to a stop point.

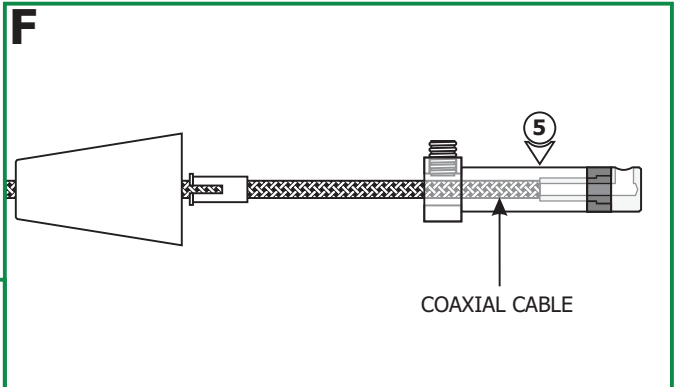

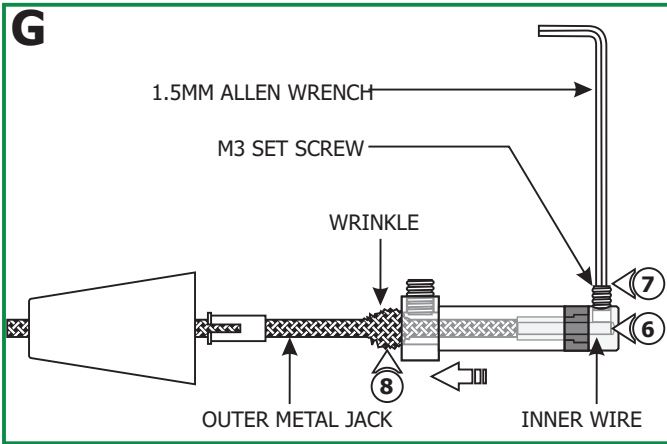

- 6:** Keep feeding the coaxial cable in until the inner wire is visible in the screw hole of the fixture connector tip. The outer metal jacket will start to wrinkle.
- 7:** Hold the fixture connector in place. Replace and tighten the M3 set screw on fixture connector tip with the 1.5mm Allen wrench.
- 8:** Pull down the outer metal jacket to smooth the wrinkles.

- 9:** Push the strain relief tube completely into the coaxial fixture connector. Make sure the slot on the strain relief tube is not inline with the M4 set screw.
- 10:** Tighten the M4 set screw with the 2mm Allen wrench.

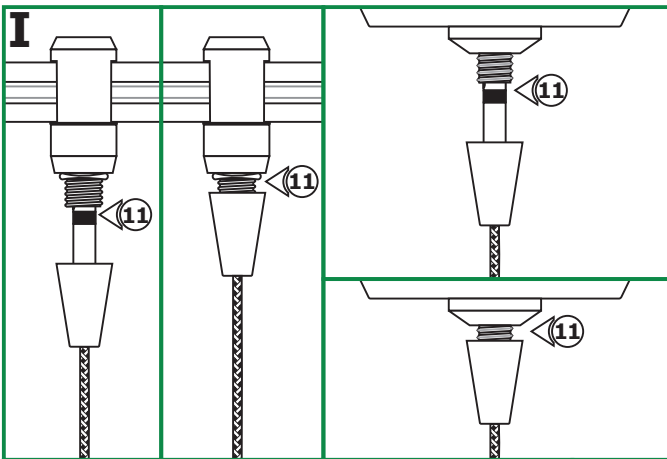
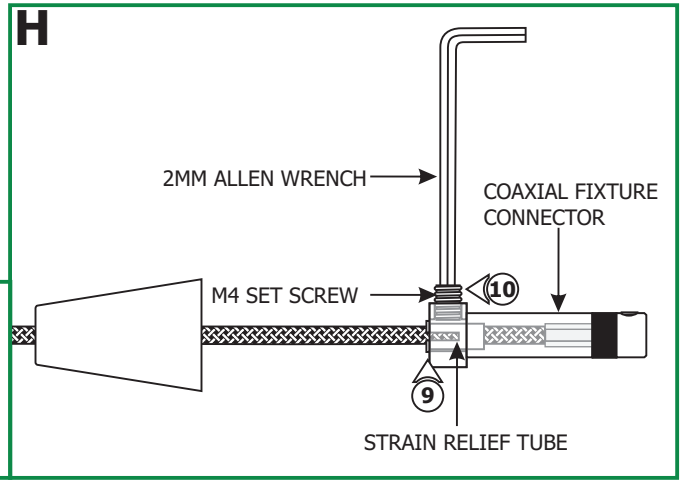

- 11:** Use fingers to tighten the Fast Jack fixture connector into the Fast Jack system connector (Monorail, Monorail 2 Circuit, or canopy connector - Refer to the instructions provided with the system connector or canopy).
- 12:** Refer to the instructions provided with the Monorail 2 Circuit fixture connector to choose Circuit #1 or Circuit #2.

