

## Installation Instructions for 20 or 24 Port Square Fast Jack Canopy

### IMPORTANT INFORMATION

- This product is dimmable with a low voltage electronic dimmer.
- This product can be installed to a 4" electrical box with round plaster ring, or to an octagon electrical box.

**SAVE THESE INSTRUCTIONS!**

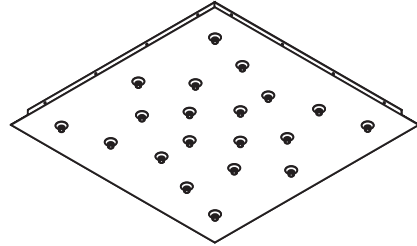

### Install the Canopy

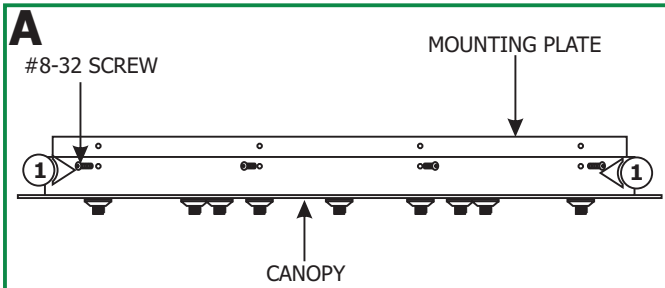

- 1:** Remove the sixteen #8-32 screws around the canopy to remove the mounting plate.

**NOTE:** It is recommended that a person to hold the mounting plate while the electrician installs it.

- 2:** Feed the power wires through mounting plate center hole.
- 3:** Align the mounting plate slots with the electrical box holes and secure it to the electrical box holes with the provided two #8-32 screws.

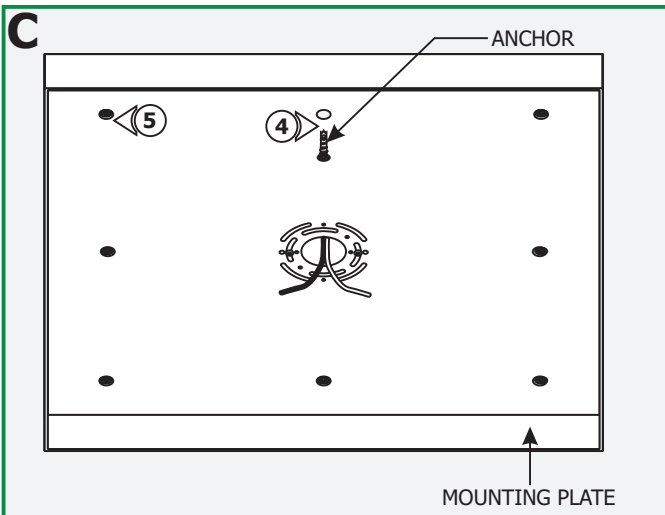
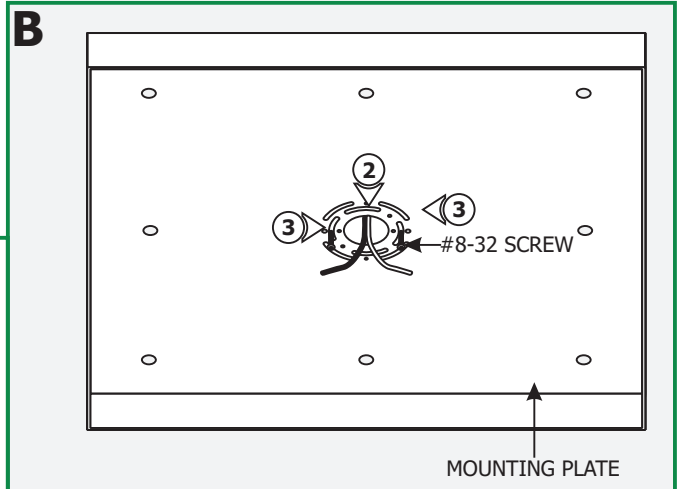

- 4:** Tap the anchors through the mounting plate holes onto the marked point up to the threaded portion with a hammer.

- 5:** Screw in the threaded portion of the anchors with a Phillips screwdriver.

**NOTE:** All 8 anchors must be installed to balance the pendants weight.

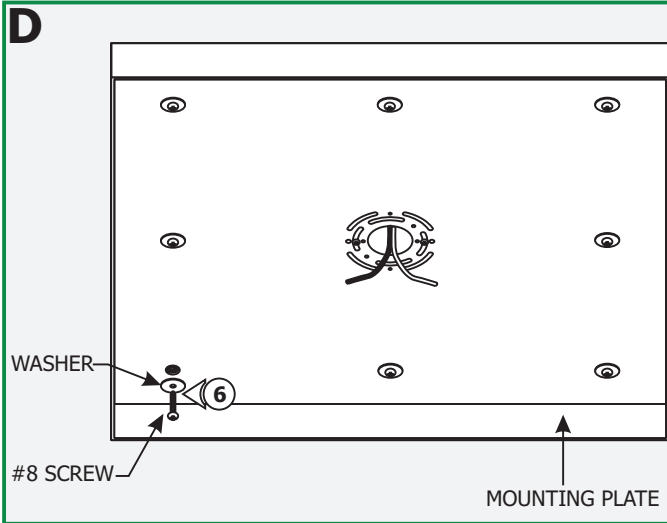

**6:** Secure the mounting plate to the anchors with the provided #8 screws and washers.

- 7:** Make sure that the mounting plate is grounded in accordance with local electrical codes.
- NOTE:** Make sure a person holds the Fast Jack canopy while the electrician connects the wires and completes the installation.
- 8:** Connect the Fast Jack white canopy wire to the neutral power wire with a wire nut.
- 9:** Connect the Fast Jack black canopy wire to the hot power wire with a wire nut.

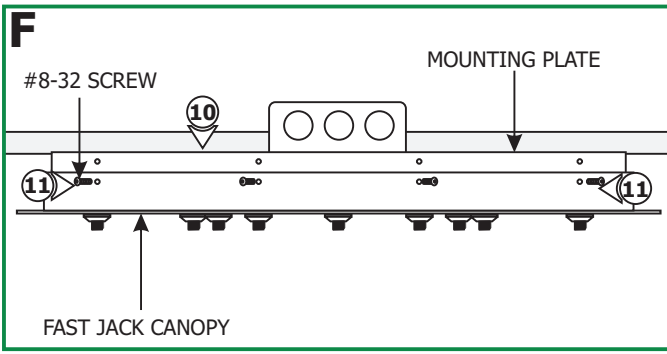
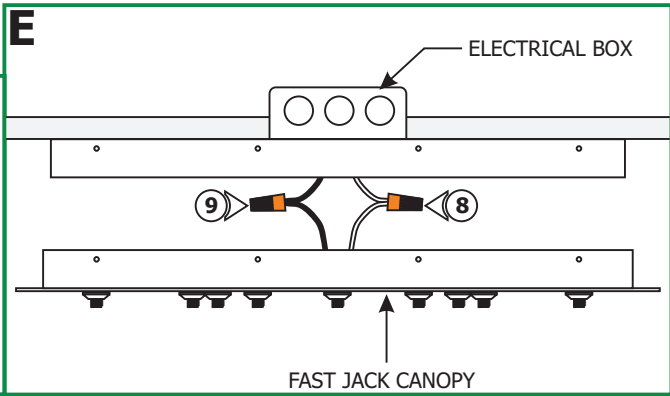

- 10:** Place all wires and wire nut connections inside the canopy.
- 11:** Place the canopy onto the mounting plate and tighten the sixteen #8-32 screws.

- CAUTION:** Maximum load of each port is 20 watt. Use only fixtures that are rated 20 Watt or less, or relamp each fixture with a Maximum 20 watt lamp.
- 12:** Use fingers to tighten each Fast Jack fixture connector into one Fast Jack canopy port.

