

Installation Instructions for Monorail 4" Round Single Power Feed Canopy With 12' Adjustable Power Feed Wires

IMPORTANT INFORMATION

- This product is ETL listed for indoor dry locations.
- This product can be installed to a 4" electrical box with round plaster ring, or to an octagon electrical box.
- Minimum electrical box volume must be 6 cubic inches (98 cubic centimeters).
- This product should be installed by a qualified electrician.

SAVE THESE INSTRUCTIONS!

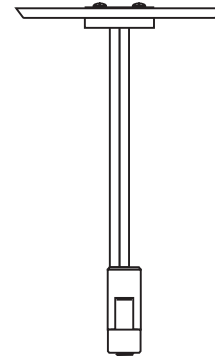

Install the Canopy

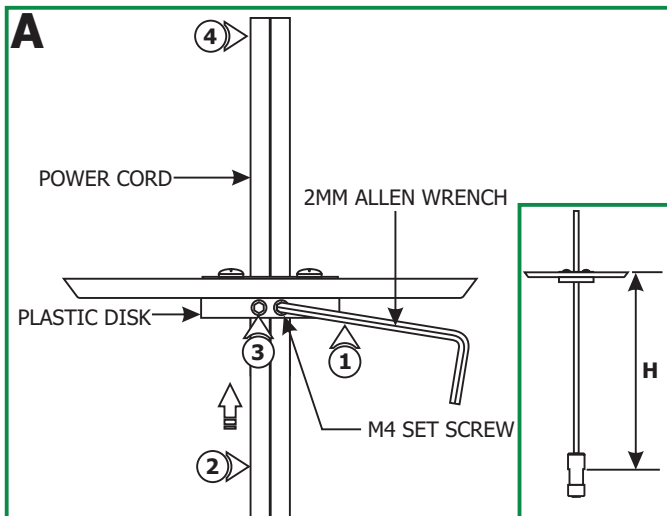

- 1: Loosen the two M4 set screws on the plastic disk with the 2mm Allen wrench provided.
- 2: Adjust the power feed wires to the desired height (from top of the canopy to top of the Monorail - illustrated as "H" in diagram A) by pushing the power feed wires into the canopy.
- 3: Tighten the two M4 set screws firmly with the 2mm Allen wrench.
- 4: Leave at least 6" of the power feed wires behind the canopy. Trim off the excess power feed wires with a sharp cutter.

NOTE: Use the universal round crossbar (provided) if the electrical box holes are not spaced 2-3/4" apart.

NOTE: The low voltage wires should be present in the electrical box. Refer to the instructions provided with the remote transformer to install the transformer and the low voltage wires before proceeding with the steps below.

5: Turn the power to electrical box off.

6: Strip 1/4" of insulation off of the power feed wires and connect each low voltage wire coming from the remote transformer to one power feed wire with a wire nut.

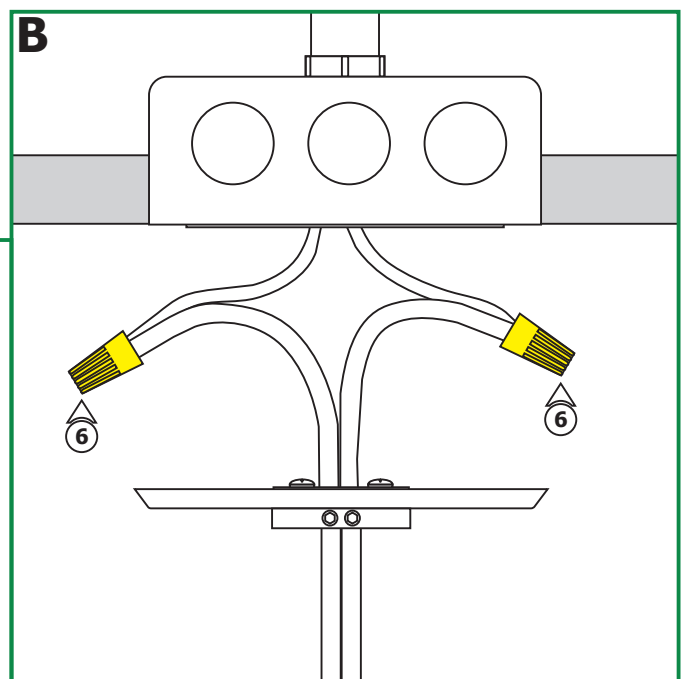

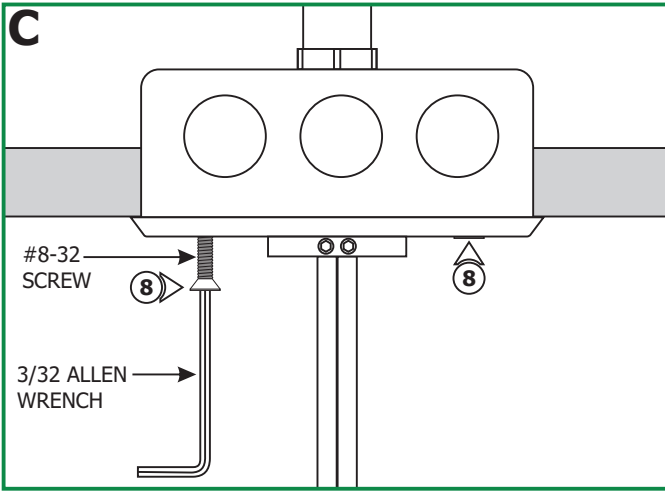

7: Place all wires inside the electrical box.

8: Secure the power feed canopy to the electrical box by tightening the two provided #8-32 screws with the 3/32 Allen wrench.

Install the Power Feed Canopy Wires to Monorail

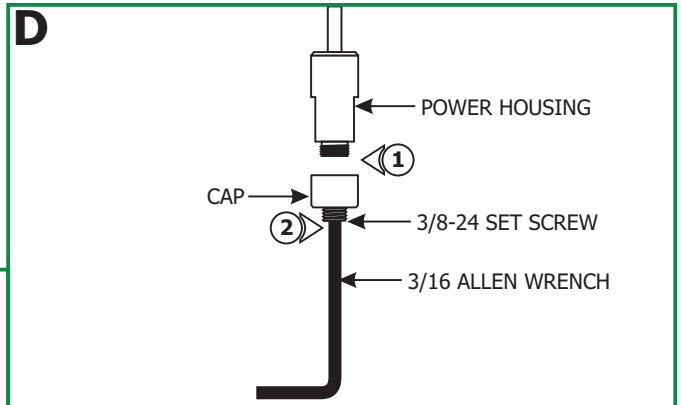

1: Unscrew the cap from power housing.

2: Slightly loosen the 3/8-24 set screw on the cap with the 3/16 Allen wrench provided, **DO NOT REMOVE THEM**

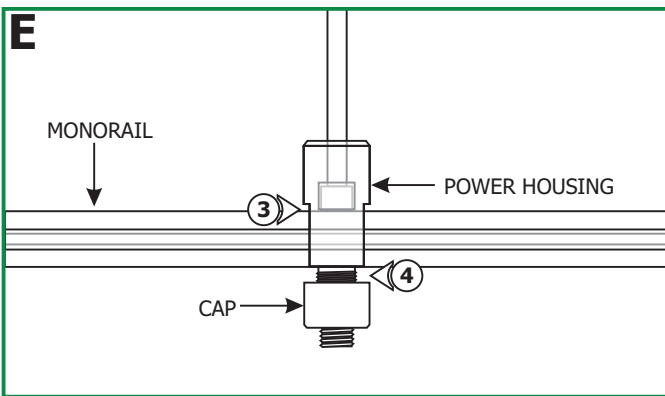

3: Place the Monorail into the power housing. Make sure that the Monorail is supported by the standoffs. Refer to the instructions provided with the standoffs.

4: Tighten the cap to the power housing. **Make sure the cap is not cross threaded.**

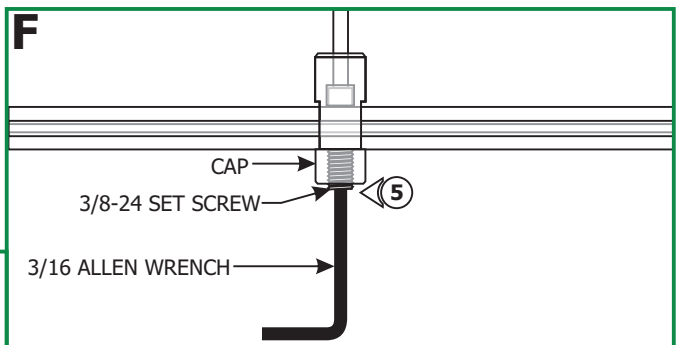

5: Tighten the 3/8-24 set screw on the cap firmly with the 3/16 Allen wrench for proper power connection.

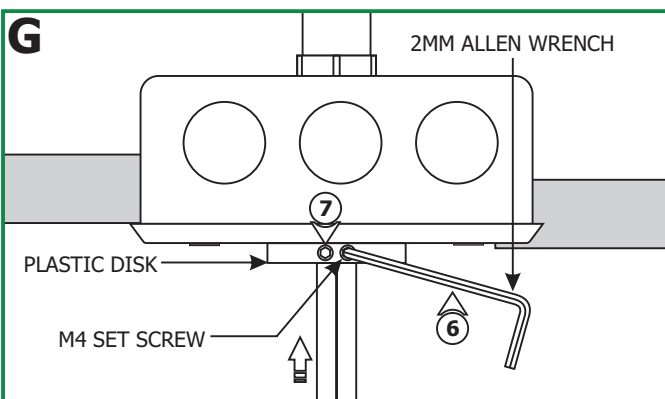

6: If the power feed wires are sagging, loosen the two M4 set screws on the plastic disk with the 2 mm Allen wrench.

7: Push the power feed wires into the canopy and tighten the two M4 set screws with the 2mm Allen wrench.