

## Installation Instructions for Glass Back Shade MR16

### IMPORTANT INFORMATION

- This product is ETL listed for indoor dry locations.

**SAVE THESE INSTRUCTIONS!**

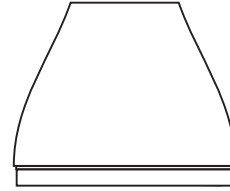

## Install the Accessory Shade in Low Rider Type Fixtures

**A**

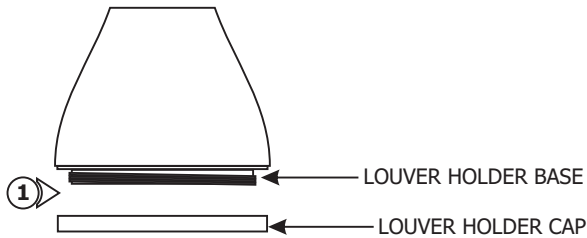

**1:** Unscrew and remove the louver holder cap from the louver holder base.

**2:** Insert the lamp into the glass shade and push the lamp pins completely into the socket holes; simultaneously push the glass shade onto the slotted shade holder.

**3:** The glass shade must fit snugly onto the slotted shade holder. If adjustment is necessary, carefully bend the slotted shade holder tabs slightly in or out with needle-nose pliers.

**B**

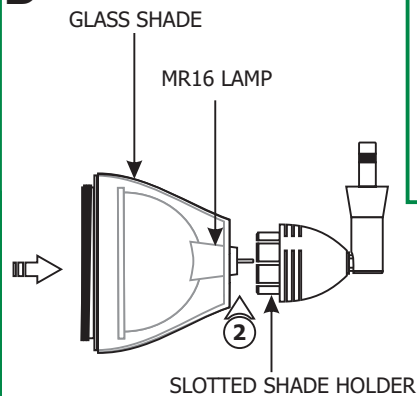

**C**

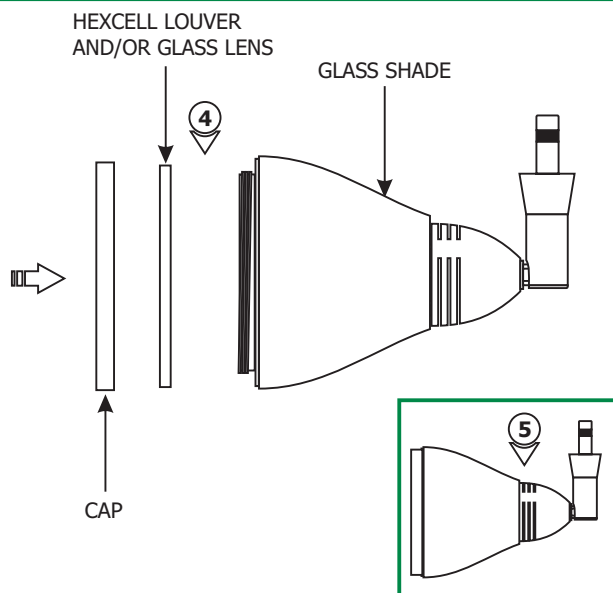

**4:** Place a hexcell louver (Optional) or a glass lens (Optional) or a combination of a hexcell louver and a glass lens on the front of MR16 lamp.

**5:** Replace and tighten the louver holder cap to the louver holder base.

# Install the Accessory shade in Vespa Type MR16 Sockets

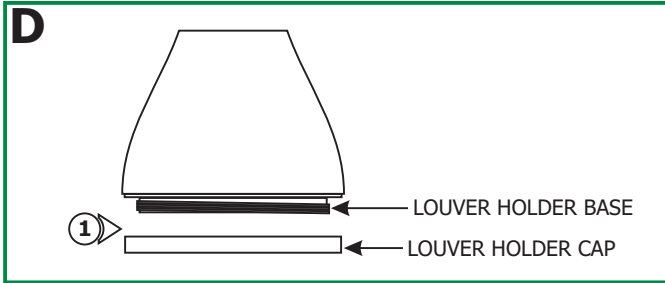

**1:** Unscrew and remove the louver holder cap from the louver holder base.

**2:** Push the spring clip completely onto the center of the socket groove until it snaps in place.

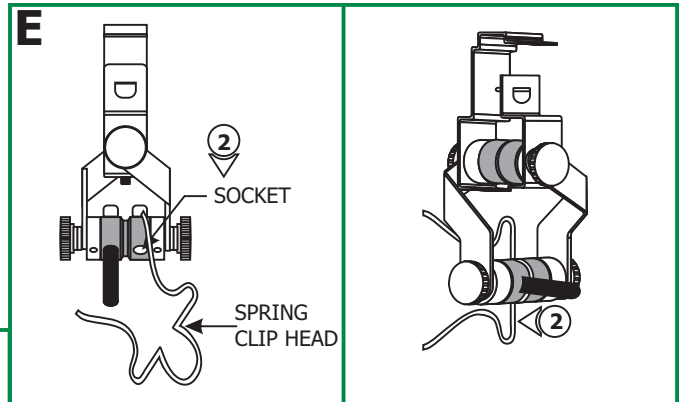

**3:** Squeeze the spring clip ends while inserting it into the glass shade.

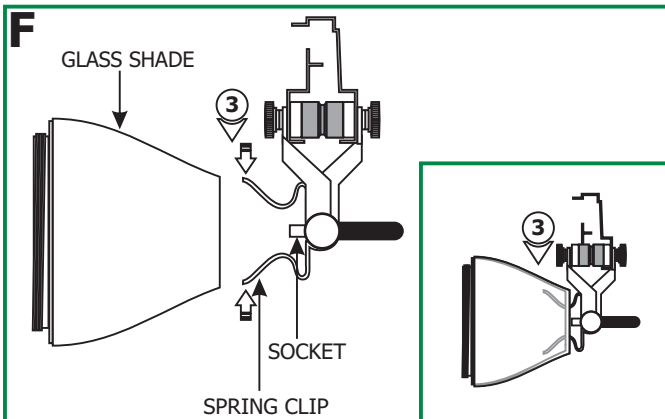

- 4:** Place the lamp into the glass shade, align and push the lamp pins completely into the socket holes.
- 5:** Place a hexcell louver (Optional) or a glass lens (Optional) or a combination of a hexcell louver and a glass lens on front of the MR16 lamp.
- 6:** Replace and tighten the louver holder cap to the louver holder base.

