



1718 W. Fullerton Chicago, IL 60614  
 Ph: 773.770.1195 • Fax: 773.935.5613  
 www.PureEdgeLighting.com • info@PureEdgeLighting.com  
 © 2016 PureEdge Lighting. All Rights Reserved.

# Installation Instructions for Flex Neon LRF5 24VDC Outdoor Wet Location

**FN-LRF5-\_\_**

## IMPORTANT INFORMATION

- This instruction shows a typical installation.
- The Outdoor Flex Neon is an IP67 rated wet location fixture featuring water tight barrel connections.
- This product bends right to left or left to right.

**SAVE THESE INSTRUCTIONS!**

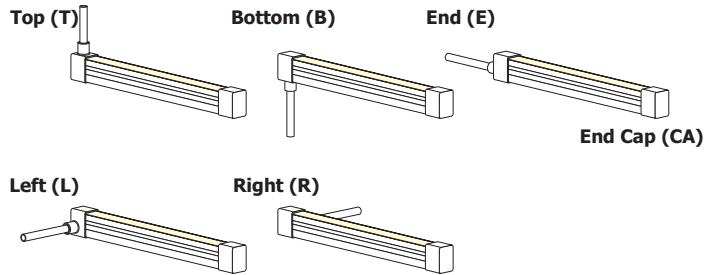

## Section One: Install the Flex Neon



**NOTE:** Omit this Section if using the Flexible Aluminum Channel. Refer to Section Three.

- 1: Determine the location for the Flex Neon.
- 2: Mark the location of the mounting clips. Mounting clips must be maximum 12" apart from each other (measure from the center of the mounting clip).

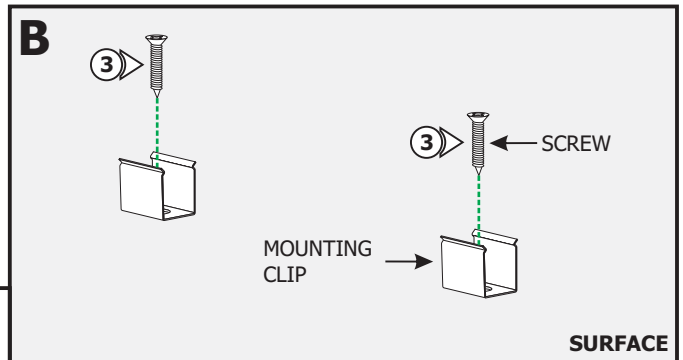

- 3: Secure the mounting clips to a wood surface by tightening the screws to each clip.

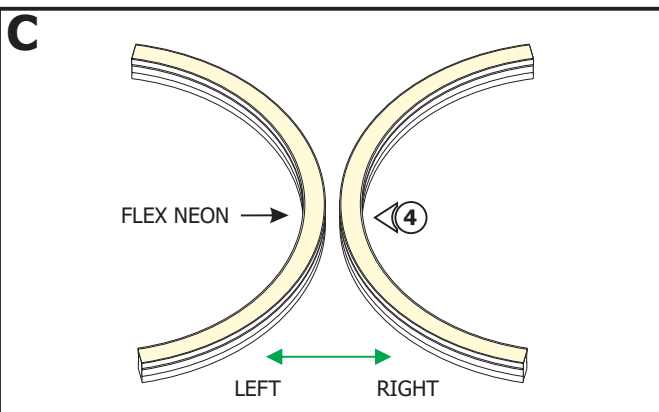

- 4: If necessary, bend the Flex Neon **ONLY** right to left or left to right.

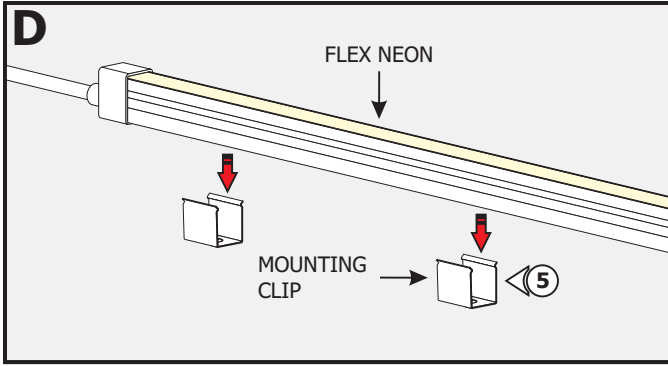

**5:** Insert the Flex Neon into each mounting clip.

## Section Two: Connect to Power

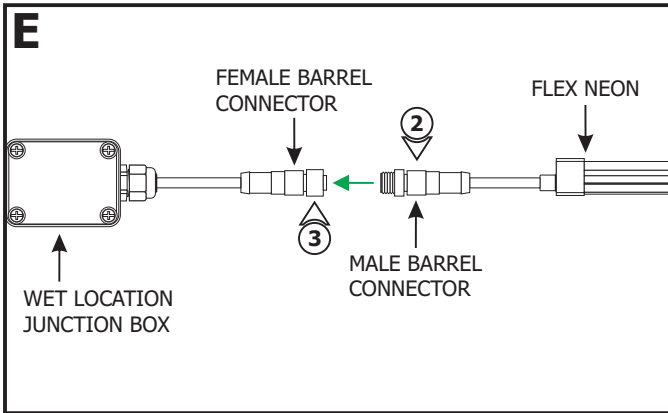

**NOTE:** Outdoor electrical connections must be made inside a waterproof junction box or using waterproof wire nut connections.

**NOTE:** Steps 1 through 3 are for the Wet Location Junction Box with Power Cable.

- 1:** Refer to the instructions provided with the wet location junction box to connect to the power supply.
- 2:** Align and push the male barrel connector of the Flex Neon into the female barrel connector going to the power supply.
- 3:** Twist the connector nut to lock in place.

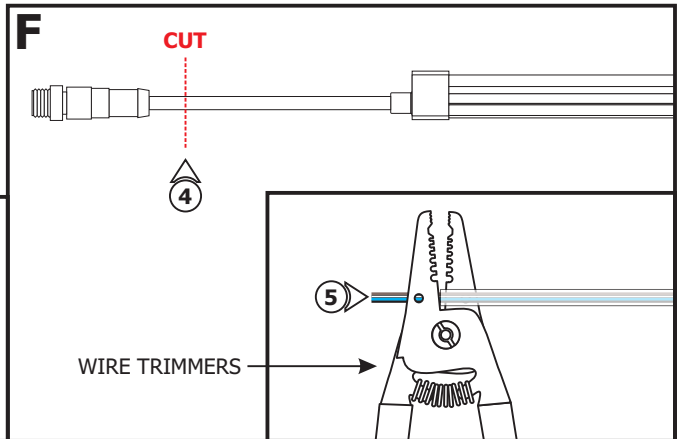

**NOTE:** Omit steps 4 through 7 if using wet location junction box.

**4:** Cut the end of the power cord that is going to be connected to power and discard the unused connector.

**5:** Use AWG wire trimmers to remove the outer insulation from wire harness where electrical connection will be made.

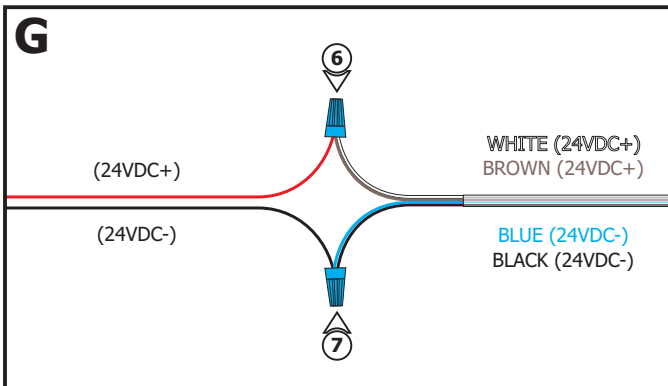

**6:** Connect the white and brown wires of the power cable to the +24VDC wire of the power supply using a wire nut.

**7:** Connect the blue and black wires of the power cable to the -24VDC wire of the power supply using a wire nut.

**8:** Refer to the wiring diagram on page 5 and the instructions provided with the power supply to complete the installation.

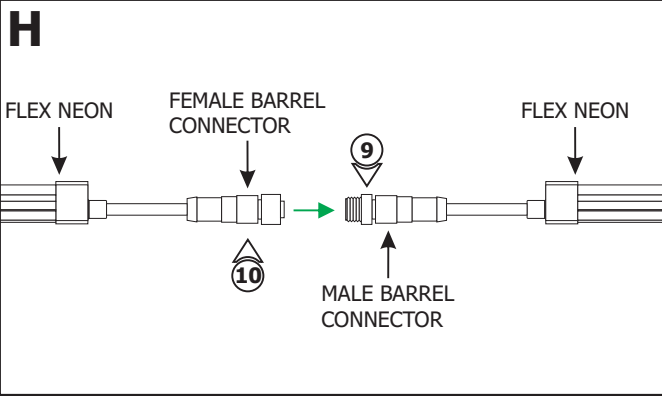

**9:** To connect additional Flex Neon, align and push the female barrel connector of one Flex Neon into the male barrel connector of the next one.

**10:** Twist the connector nut to lock in place. Repeat for any additional sections.

**NOTE:** Ensure that additional Flex Neon are properly supported and powered.

### Section Three: Install the Flex Neon with Flexible Aluminum Channel

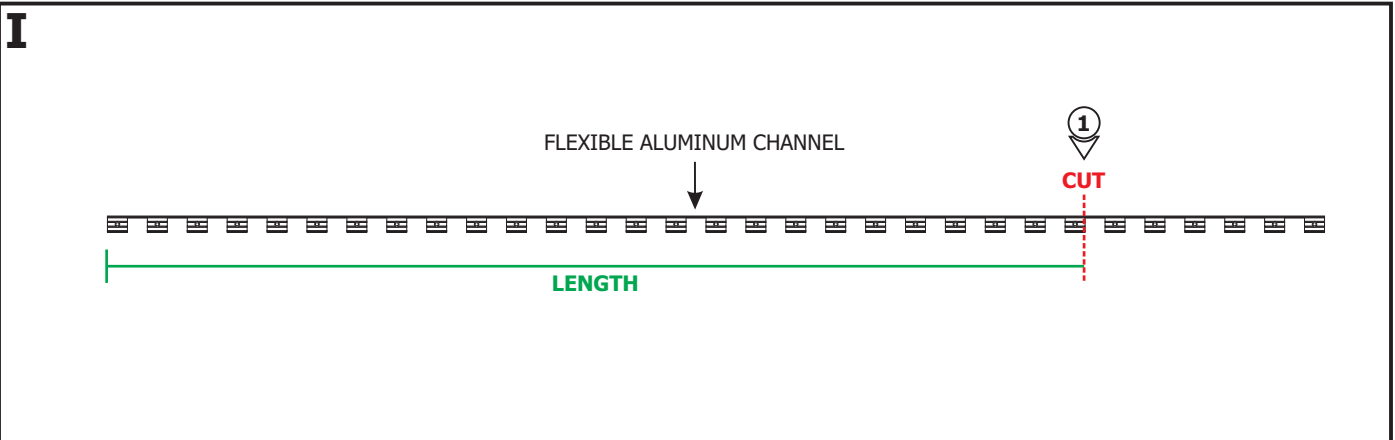

**1:** If necessary measure and cut **ONLY** the Flexible Aluminum Channel to length.

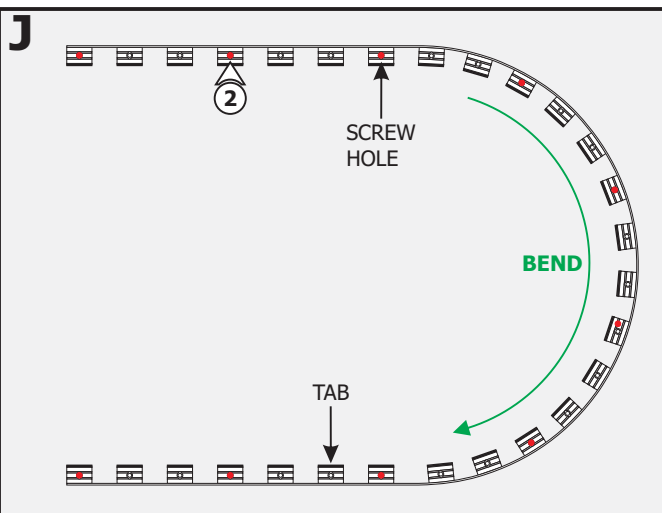

**2:** Determine the location of the Flexible Aluminum Channel and mark every fourth tab screw holes.

**NOTE:** The Flexible Aluminum channel bends in both directions. For simple curves or circles, it is recommended to bend the channel toward the tabs.

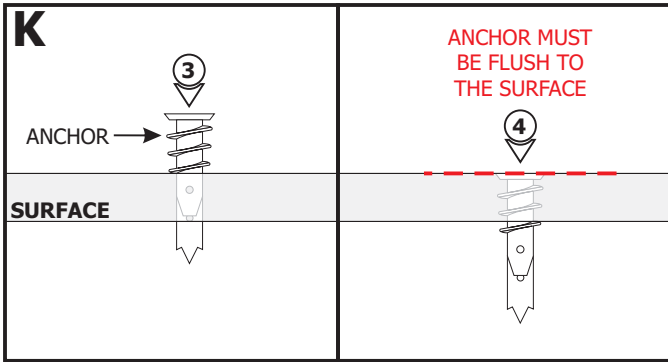

**NOTE:** Step 3 and 4 are for drywall mounting. Omit these steps if mounting to a wood surface directly.

**3:** Anchors are not provided. Tap the anchors onto the marked points up to the threaded portion with a hammer.

**4:** Screw in the threaded portion of the anchors with a Phillips screwdriver.

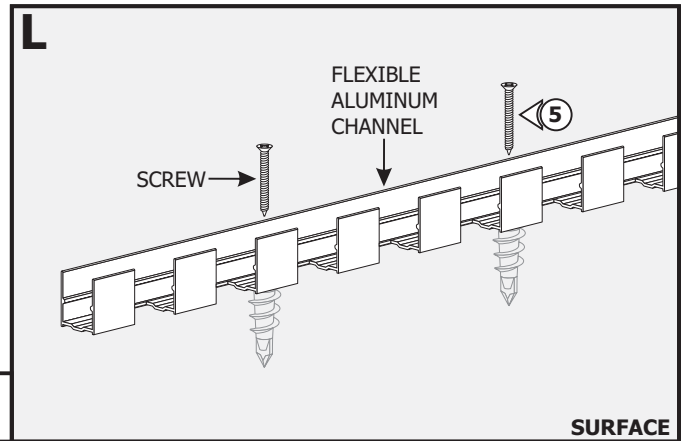

**5:** Secure the Flexible Aluminum Channel to the anchors using screws.

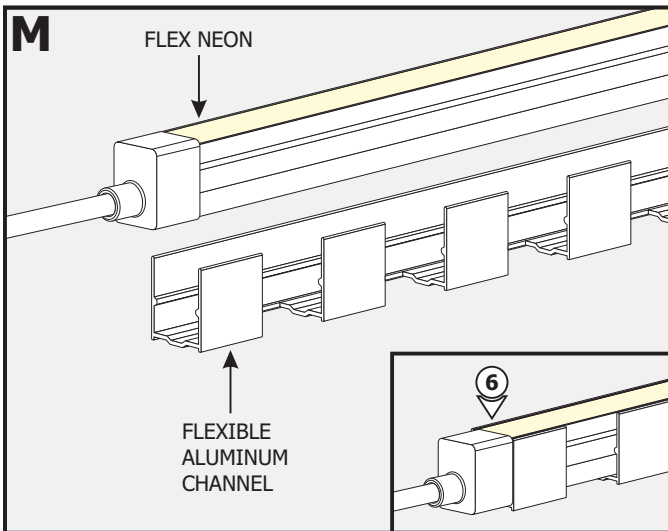

**6:** Carefully push the Flex Neon completely inside the Flexible Aluminum Channel, leaving the end cap outside of the channel.

**7:** Remove the backing from the channel cover. Firmly press down on the Flexible Aluminum Channel tabs while removing the rest of the backing.

**8:** Refer to Section Two to connect to power.

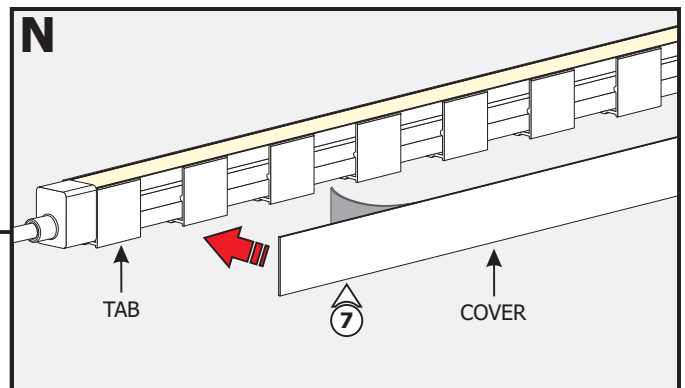

# General Wiring Diagram

