



1718 W. Fullerton Chicago, IL 60614  
 Ph: 773.770.1195 • Fax: 773.935.5613  
 www.PureEdgeLighting.com • info@PureEdgeLighting.com  
 © 2016 PureEdge Lighting. All Rights Reserved.

# Installation Instructions for Completed Channel .3 Surface Mount with Lazer Strip

LCS.3-\_\_



## IMPORTANT INFORMATION

- This instruction shows a typical installation.

**SAVE THESE INSTRUCTIONS!**

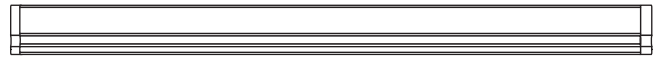

## Section One: Install the Light Channel

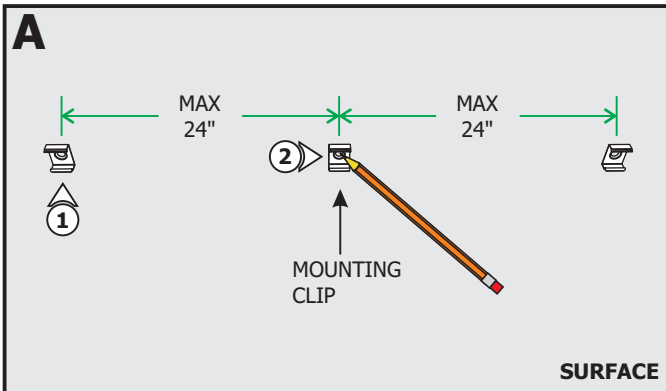

- 1: Determine the location of the Light Channel .3 Surface Mount.
- 2: Mark the location of the mounting clips evenly on a straight line. Mounting clips must be maximum 24" apart from each other.

- NOTE:** Steps 3 and 4 are for drywall mounting. Omit these steps if mounting to a wood surface directly.
- 3: Tap the anchors onto the marked locations up to the threaded portion with a hammer.
  - 4: Screw in the threaded portion of the anchors with a Phillips screwdriver.

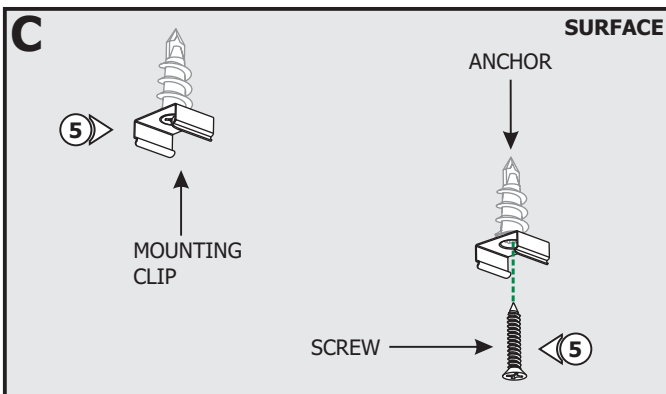
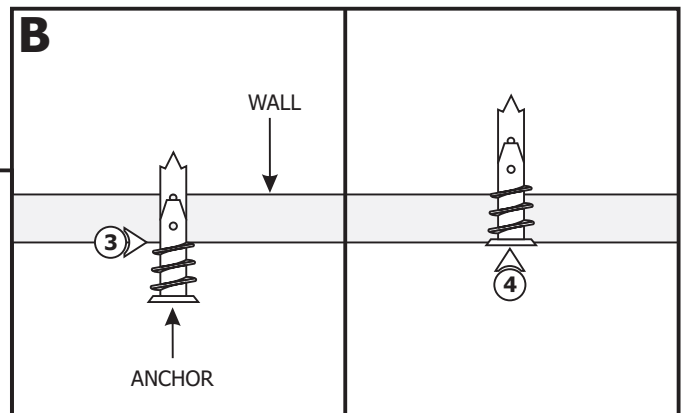

- 5: Align the mounting clips to the anchors and secure each clip to each anchor by tightening the #8 screws.

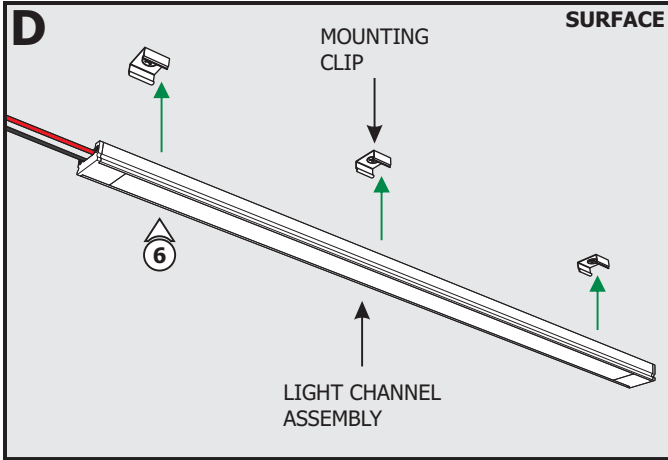

**6:** Snap the light channel assembly to the mounting clips.

**7:** Cut the end of the power cord that is going to be connected to power and discard the unused connector. Strip the ends of the wires.

**NOTE:** Follow the instructions provided with the power supply to power the light channel.

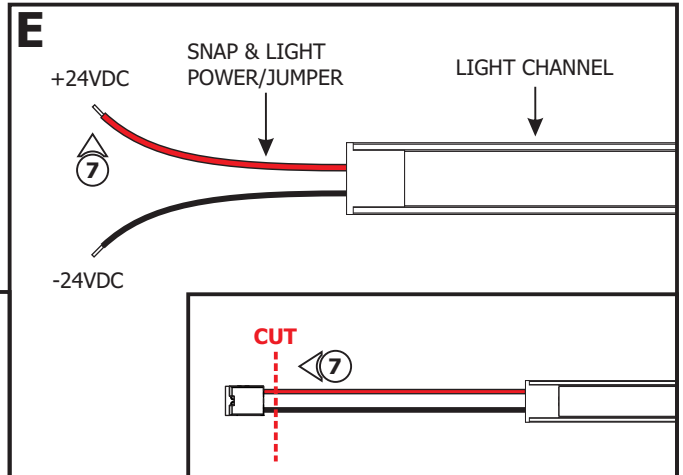

## General Wiring Diagram

