



1718 W. Fullerton Chicago, IL 60614
 Ph: 773.770.1195 • Fax: 773.935.5613
 www.PureEdgeLighting.com • info@PureEdgeLighting.com
 © 2016 PureEdge Lighting. All Rights Reserved.

Installation Instructions for Wet Location Junction Box with 6" Power Cable

OC-2RE-_CON-6IN-W

IMPORTANT INFORMATION

- This instruction shows a typical installation.

SAVE THESE INSTRUCTIONS!

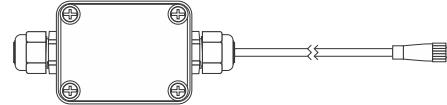

Install the Wet Location Junction Box

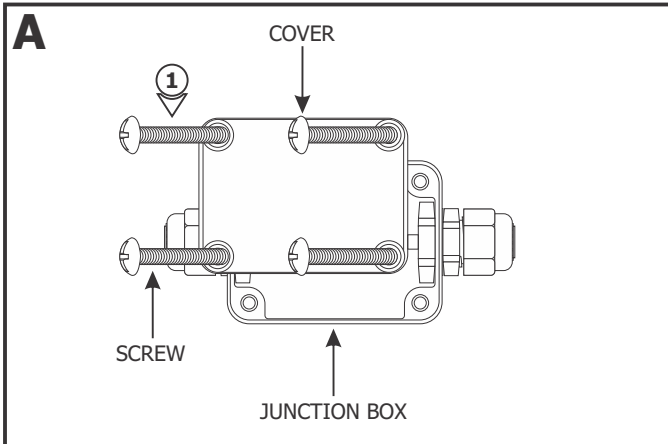

1: Remove the four Phillips screws on the wet location junction box to remove the cover.

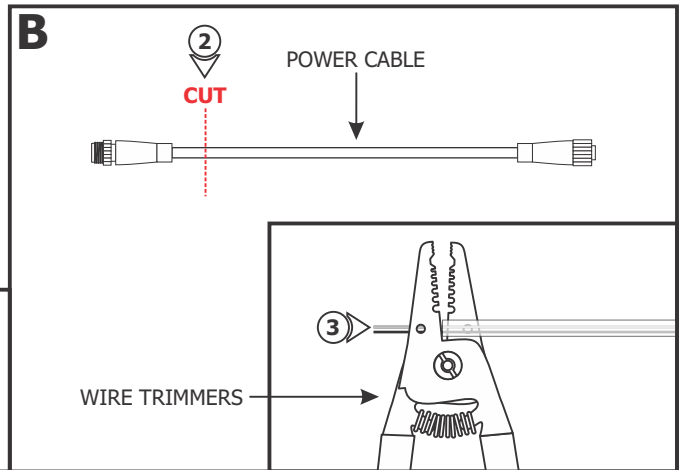

2: Keep one end of the connector (either the male or female end) that is going to be connected to the first fixture. Cut and discard the other end connector.

3: Use AWG wire trimmers to remove the outer insulation from the wire harness where electrical connection will be made.

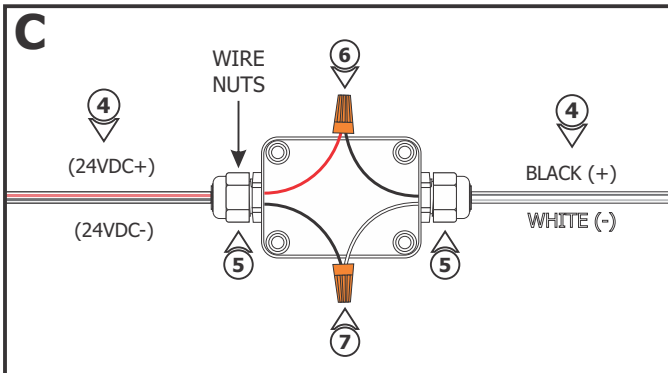

Static White Configurations:

- 4:** Insert the low voltage cable coming from the power supply and the power cable into the wet location junction box.
- 5:** Tighten the waterproof wire nuts on the wet location junction box to lock in place.
- 6:** Connect the black wire of the power cable to the +24VDC wire of the power supply using a wire nut.
- 7:** Connect the white wire of the power cable to the -24VDC wire of the power supply using a wire nut.

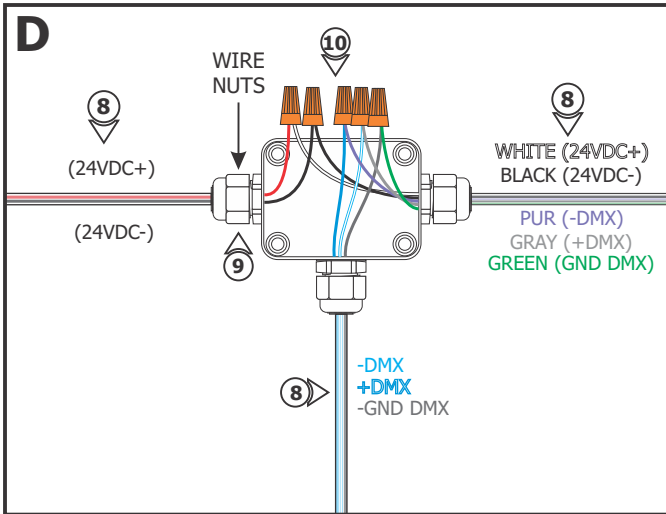

RGB/RGBW Configurations:

8: Insert the low voltage cable coming from the power supply, the DMX cable coming from the controller, and the power cable into the wet location junction box.

9: Tighten the waterproof wire nuts on the wet location junction box to lock in place.

NOTE: The color of the power cord wires are represented as:

- White for +24VDC
- Black for -24VDC
- Purple for -DMX
- Gray for +DMX
- Green for GND DMX

10: Refer to the wiring diagram on Page 4 and the instructions provided with the power supply and controller to complete the installation.

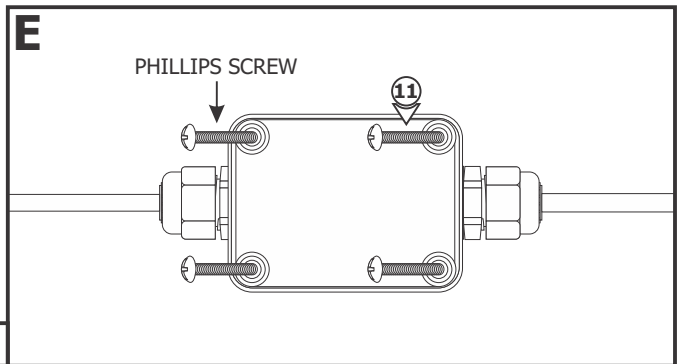

11: Replace the junction box cover with the Phillips screws.

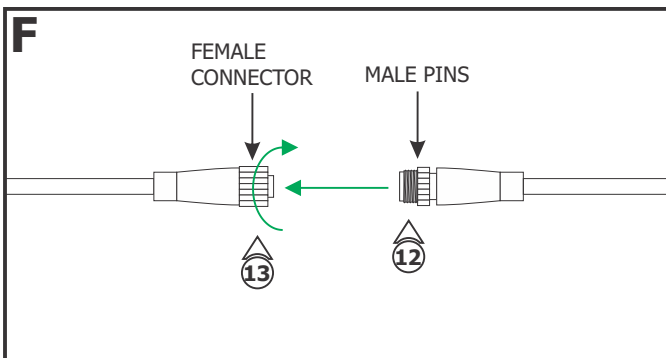

12: Align the power cables from the wet location junction box and fixture and push into place, ensuring that the female connector and male pins mate properly.

13: Twist the connector nut to lock in place.

General Wiring for Static White

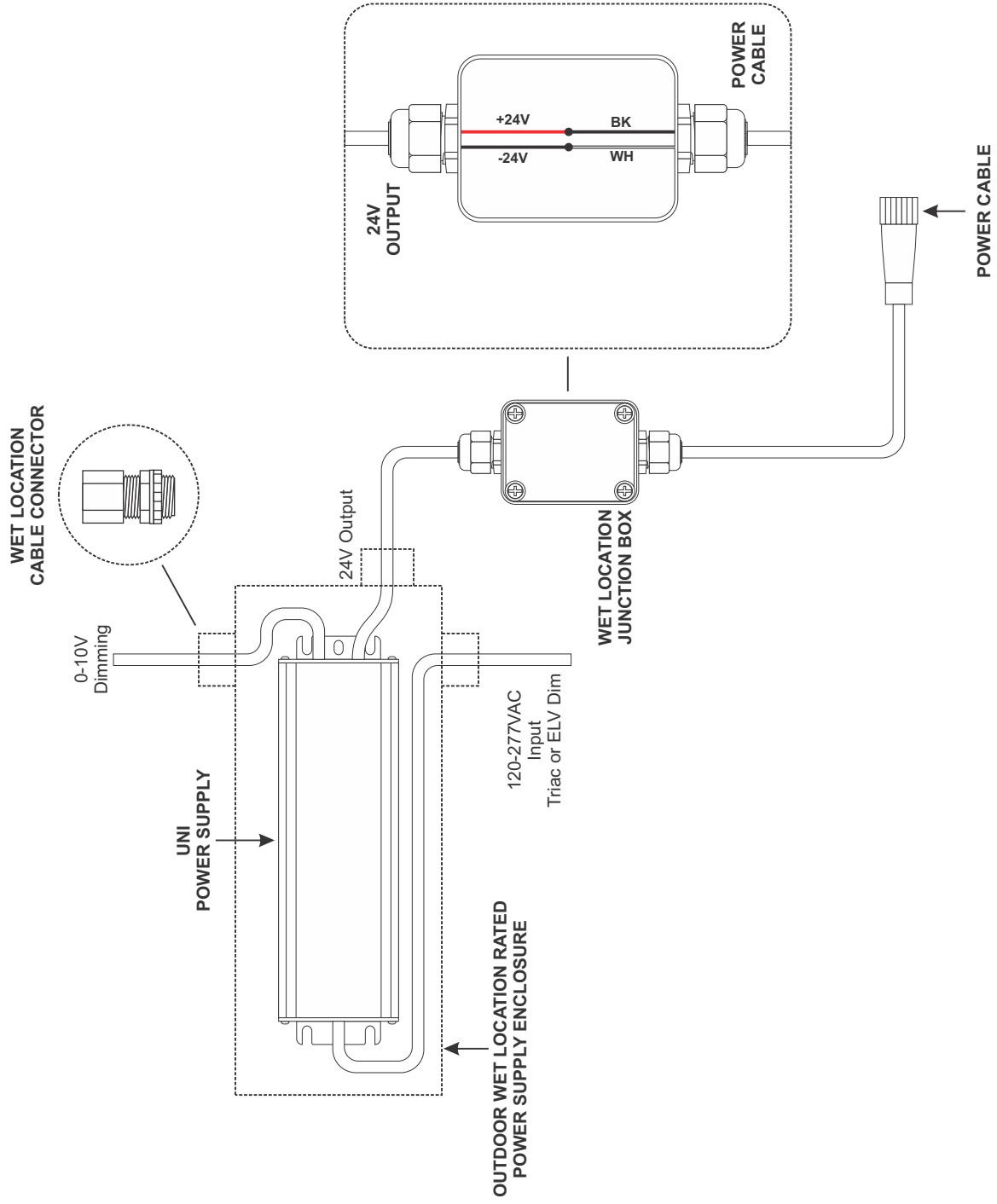

General Wiring for RGB & RGBW

