



1718 W. Fullerton Chicago, IL 60614
 Ph: 773.770.1195 • Fax: 773.935.5613
 www.PureEdgeLighting.com • info@PureEdgeLighting.com
 © 2016 PureEdge Lighting. All Rights Reserved.

Installation Instructions for Pipeline 2 Suspension Downlight with Power - Center Feed

P2SD_P-C_ _

IMPORTANT INFORMATION

- This product is suitable for indoor locations.
- This instruction shows a typical installation.
- Additional aircraft cables are included for support when fixture lengths are 72" and longer.

SAVE THESE INSTRUCTIONS!

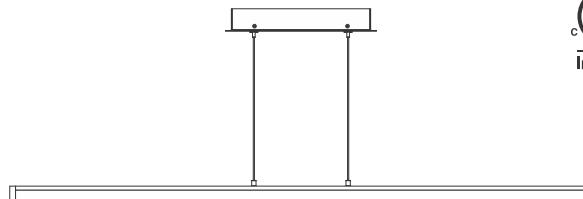

Section One: Install the Canopy

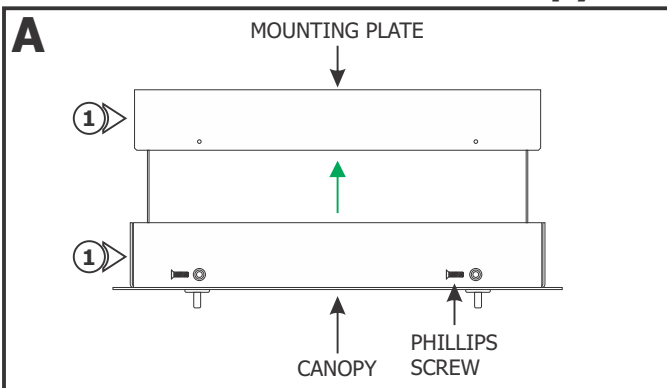

1: Remove the four Phillips screws from the canopy to remove the mounting plate.

NOTE: It is recommended more than one person to assist in this installation.

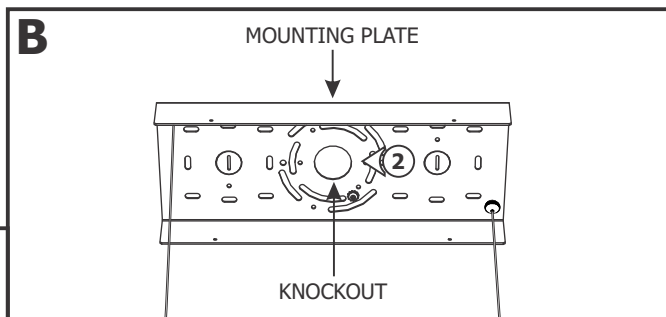

2: Select the appropriate knockout on the mounting plate and remove it using a flathead screwdriver or other appropriate tool.

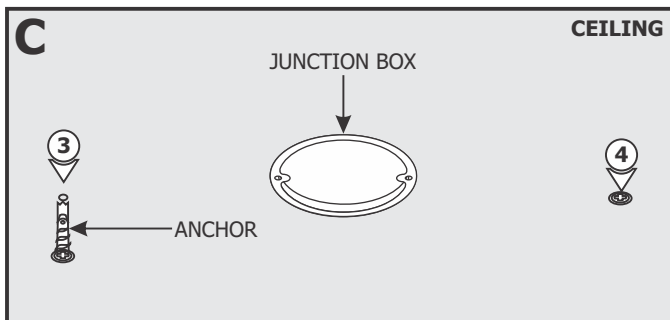

3: Align the mounting plate holes with the junction box. Mark one point on each side of the junction box onto the ceiling.

NOTE: Omit step 4 if mounting directly onto a wood surface.

4: Tap the anchors onto the marked points up to the threaded portion with a hammer. Then screw in the threaded portion with a Phillips screw driver.

5: Make sure the mounting plate is grounded in accordance with local electrical codes.

6: Feed the line voltage power wires through the mounting plate knockout.

7: Secure the mounting plate to the junction box and anchors using the provided screws and washers.

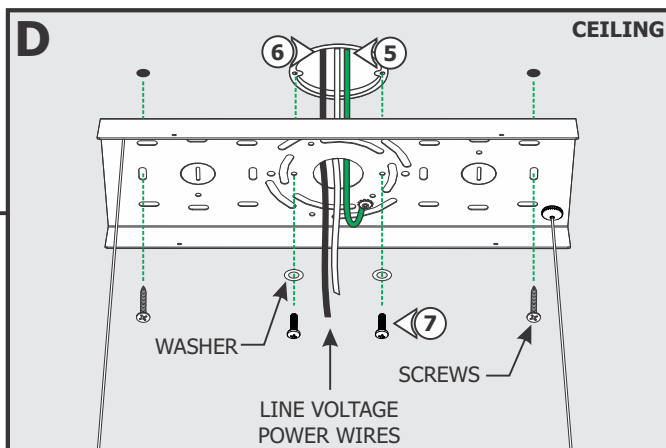

Section Two: Power the Fixture

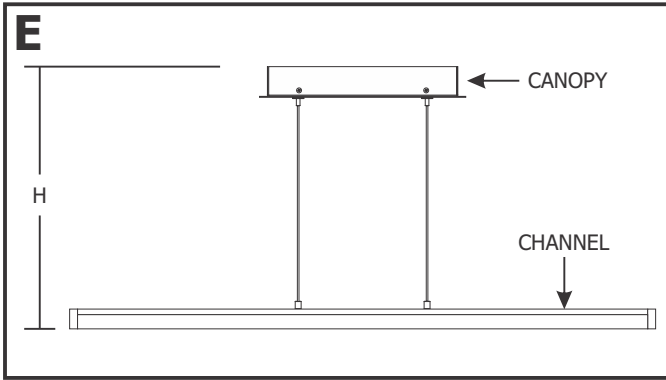

1: Determine the fixture height (H), from the bottom of the channel to the top of the canopy.

NOTE: Cord grips hold the fixture weight only. **DO NOT** pull on the fixture during installation or cleaning which may cause the power wires to nick and short.

NOTE: If cable is curled or kinked, straighten by holding between the shaft of a screwdriver and thumb and pulling the cable through.

2: Push each cable through the cord grips on the canopy. Adjust the fixture height by pushing the cord grip tab to slide the fixture up and down. Release the cord grip tab to lock the cable in place.

3: Identify the power cable which is marked with a "POWER" label.

NOTE: The cable with a "SUPPORT" label is for support only. **DO NOT** strip and power the support cable.

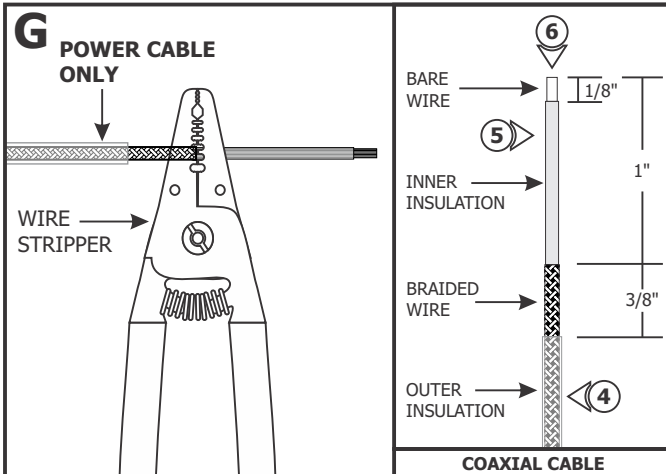
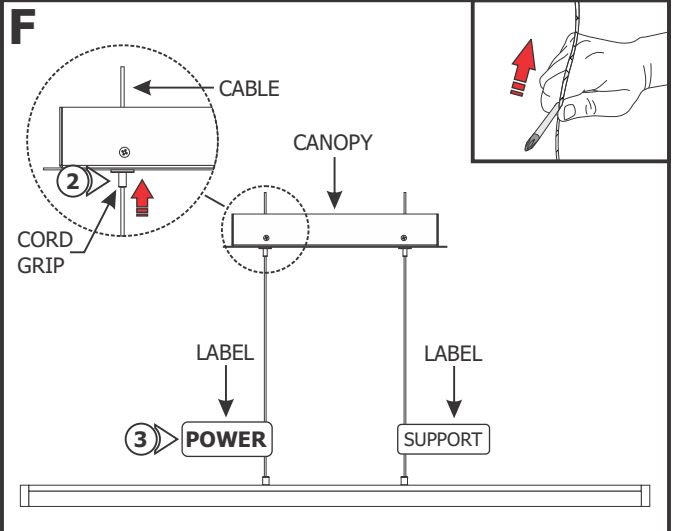

NOTE: Scan the QR Code to watch the video clip of the following steps or visit www.PureEdgeLighting.com/video_feed/installation_cxc_connector

NOTE: Steps 4 through 15 are for the "POWER" cable only.

4: Use the 18AWG hole of the wire stripper to remove 1-3/8" of the outer insulation to expose the braided wire.

5: Use the 18AWG hole of the wire stripper to remove 1" of the braided wire making sure not to nick the inner wire insulation.

6: Use the 20AWG hole of the wire stripper to remove 1/8" of the inner insulated wire.

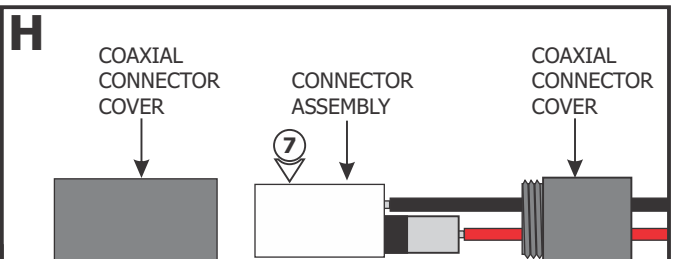

7: Unscrew the coaxial connector covers and remove from the connector assembly.

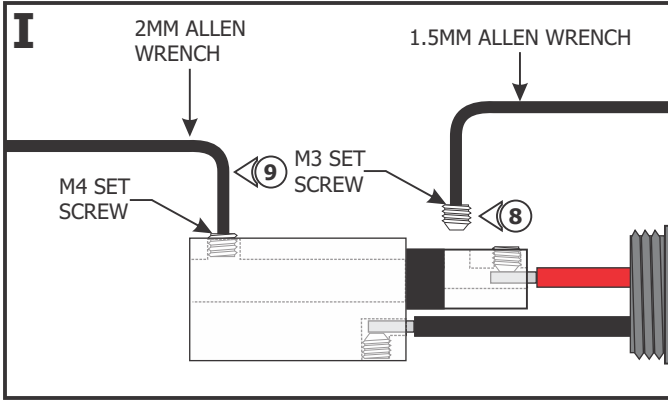

8: Using the provided 1.5mm Allen wrench, remove the M3 set screw from the coaxial connector assembly.

9: Using the provided 2mm Allen wrench to loosen (do not remove) the M4 set screw.

10: Slide the connector cover over the coaxial cable.

11: Place the ferrule over the 3/8" braided wire of the coaxial cable.

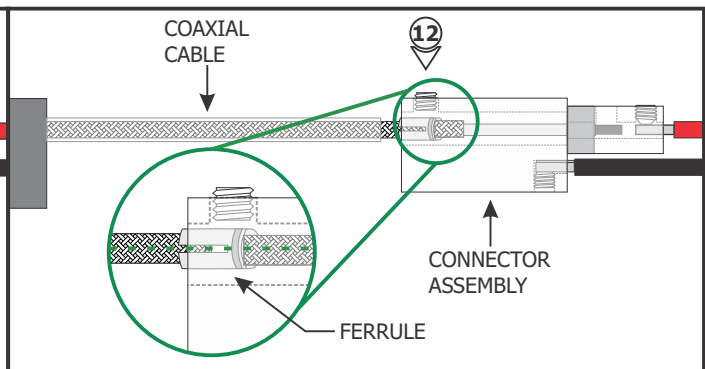
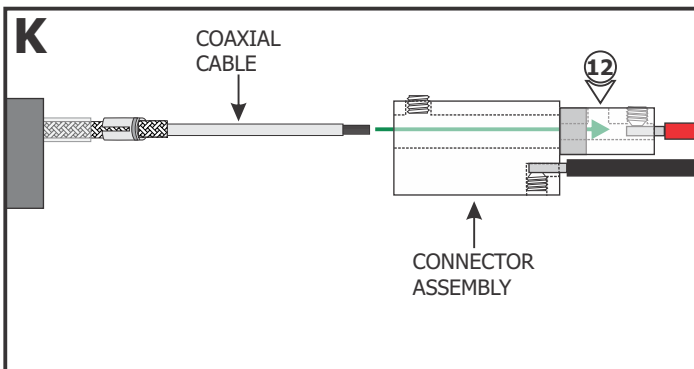
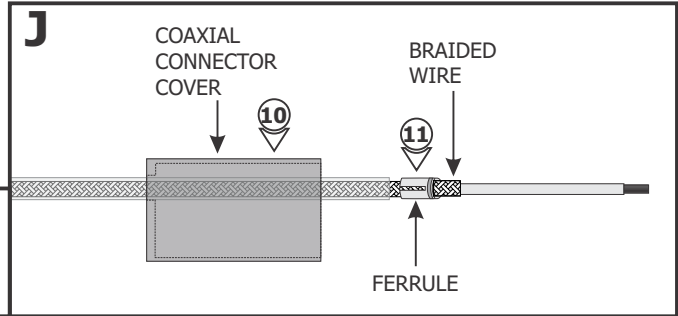

12: Insert the coaxial cable into the coaxial connector until the wires of the center conductor are visible through the M3 set screw hole.

NOTE: Ensure that the split in the ferrule is aligned 90° from the M4 set screw (see inset).

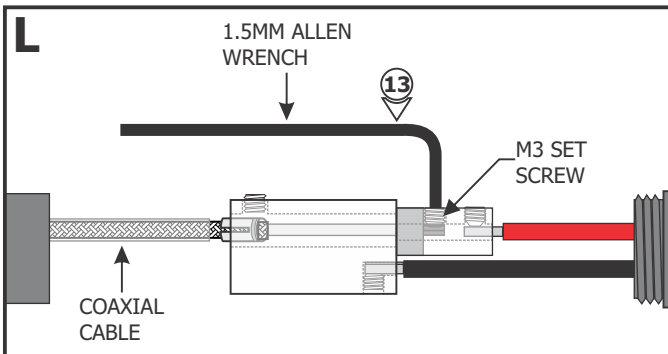

13: Use the provided 1.5mm Allen wrench to replace and securely tighten the M3 set screw.

14: Use the provided 2mm Allen wrench to securely tighten the M4 set screw until it squeezes the wire ferrule tightly to the coaxial cable.

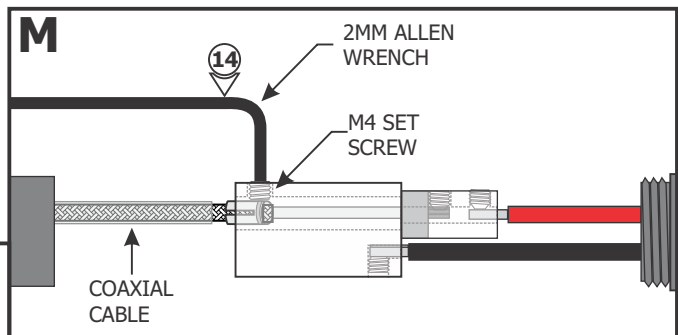

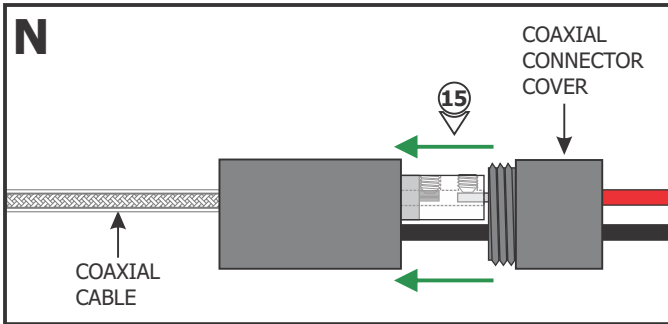

15: Replace the coaxial connector cover and tighten into place.

16: Connect the red wire of the coaxial connector to the +24VDC power supply wire using a wire nut.

17: Connect the black wire of the coaxial connector to the -24VDC power supply wire using a wire nut.

18: Connect the white wire of the power supply to the neutral wire using a wire nut.

19: Connect the black wire of the power supply to the line wire using a wire nut.

CAUTION: Test the fixture before continuing.

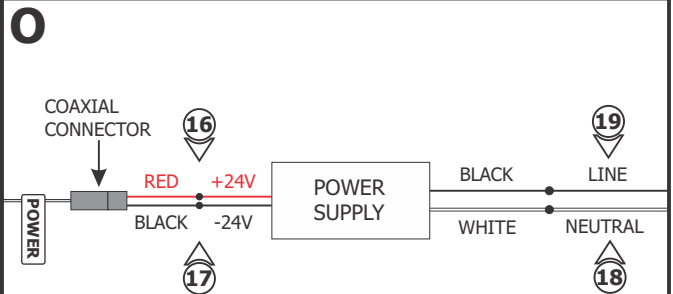

DO NOT USE SUPPORT WIRE FOR POWER

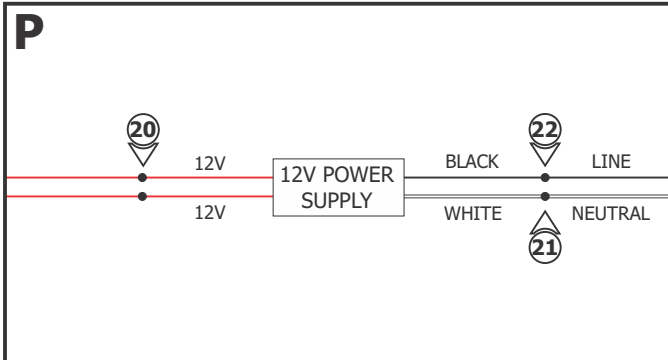

For Models Configured with Fast Jack Port:

20: Connect each low voltage red wire from the power supply to each red wire of the Fast Jack connector using a wire nut.

21: Connect the neutral power wire from another 120VAC circuit to the white wire of the power supply with a wire nut.

22: Connect the line wire from the same 120VAC circuit to the black wire of the same power supply with a wire nut.

23: Place all the wires and wire nut connections inside the canopy.

24: Align and secure the canopy to the mounting plate by tightening the four screws.

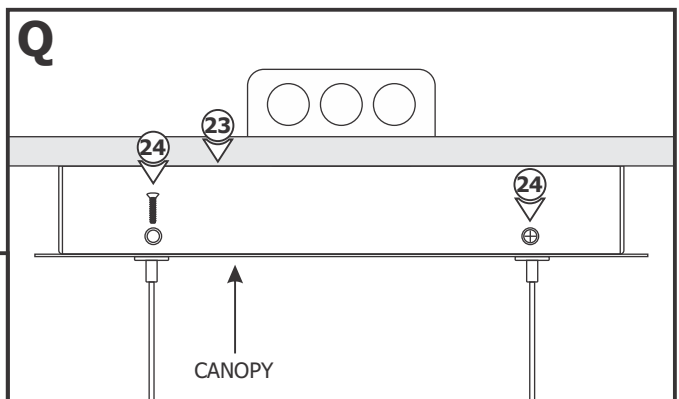

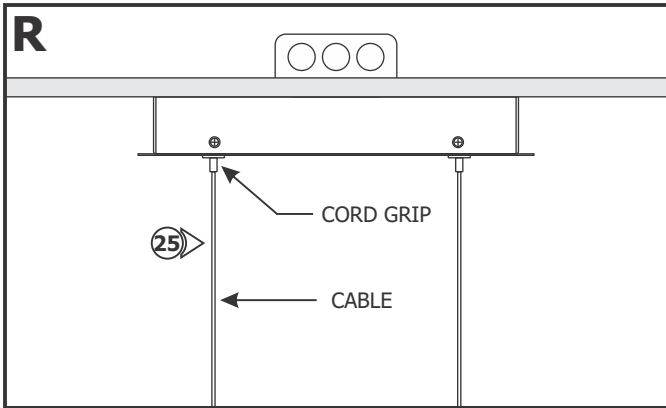

25: To make any adjustments to the fixture height, push the cord grips to slide the fixture up and down until the desired height is achieved. Release the cord grips to lock the cables in place.

Section Three: Install Additional Support

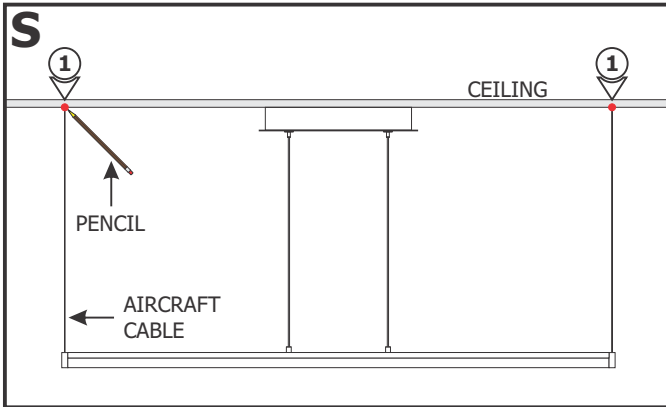

NOTE: Follow these steps if the Pipeline Fixture (72 inches and longer) is provided with additional supports.

1: Lift the ends of the aircraft cables against the ceiling to mark the locations of the standoffs.

NOTE: Steps 2 and 3 are for drywall mounting. Omit these steps if mounting to a wood surface directly.

2: Tap the anchors onto the marked points up to the threaded portion with a hammer.

3: Screw in the threaded portion of the anchors with a Phillips screwdriver.

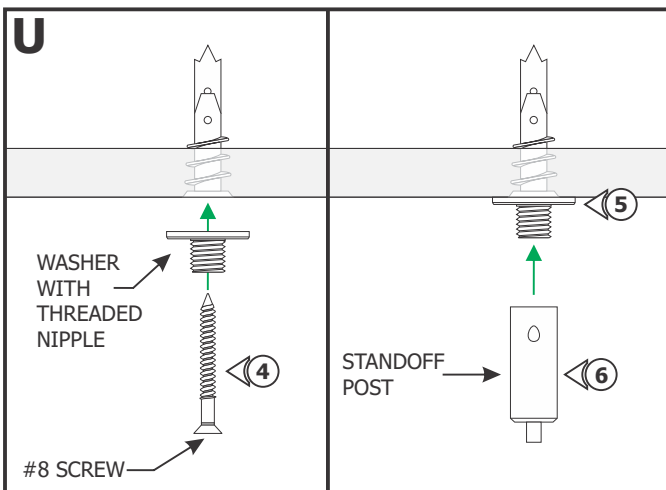
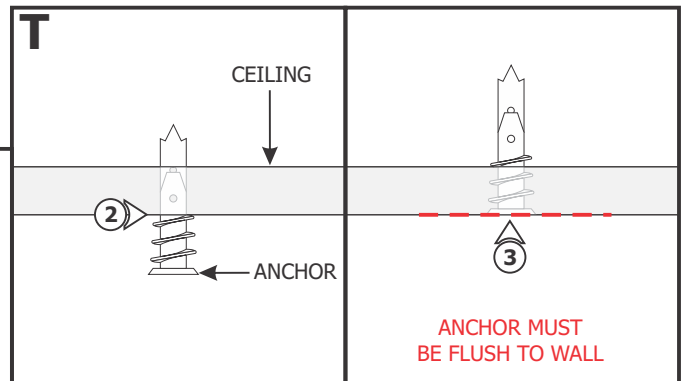

4: Feed the #8 screw through the washer with threaded nipple into the anchor.

5: Tighten the #8 screw completely into the anchor.

6: Tighten the standoff post completely onto the threaded nipple.

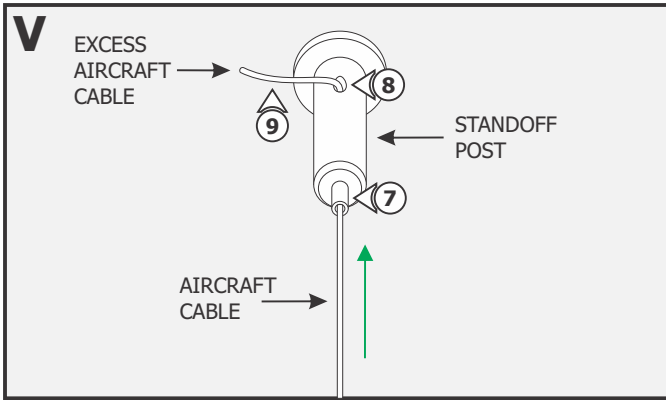

7: Feed the aircraft cable coming from the channel through the standoff post.

8: Adjust the fixture height by pushing the tab and pulling the aircraft cable out of the side of the standoff post. Release the tab to secure the cable in place.

9: If necessary, trim excess aircraft cable using sharp cutters.

General Wiring Diagram

