



1718 W. Fullerton Chicago, IL 60614
 Ph: 773.770.1195 • Fax: 773.935.5613
 www.PureEdgeLighting.com • info@PureEdgeLighting.com
 © 2016 PureEdge Lighting. All Rights Reserved.

Installation Instructions for **ST5A Stomp Strip Warm Dim 5W/ft 24VDC with 6' Soldered Leads**

ST5A-24V-_-_D

IMPORTANT INFORMATION

ETL LISTED



Intertek
3028534

- Conforms to UL STD 1598 & UL STD 2108 Certified to CAN/CSA STD C22.2 NO 250.0
- Suitable for Under-Cabinet Mount
- Dry Location Only
- Use Only With Class 2 Power Unit
- Peut être fixé Sous Une Armoire
- Pour Emplacements Secs Seulement
- Utiliser Seulement Avec Classe 2 Unité d'alimentation électrique



SAVE THESE INSTRUCTIONS!

Section One: Prepare the Stomp Strip

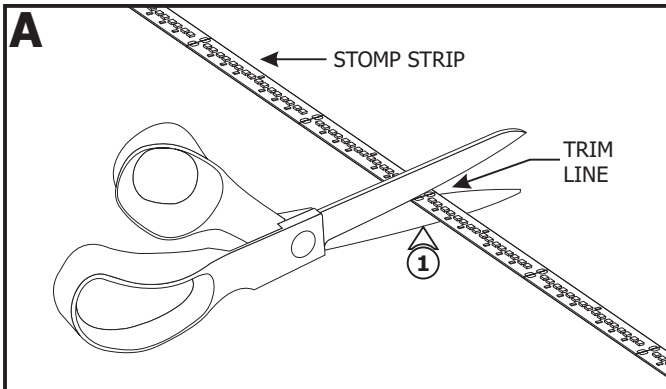

- 1:** Determine the amount of LED strip needed.
- 2:** If necessary trim the LED strip at the marked line above the contact (every 3" apart) with a sharp scissor to fit the design.

NOTE: Do not trim the strip at unmarked sections which may cause that section of the strip not to light up.

- 3:** Carefully remove the backing from the LED strip, make sure not to remove the tape. Firmly press down the adhesive portion of the LED strip onto the mounting surface while removing the rest of the backing, making sure there are no air bubbles that can cause surface irregularities.

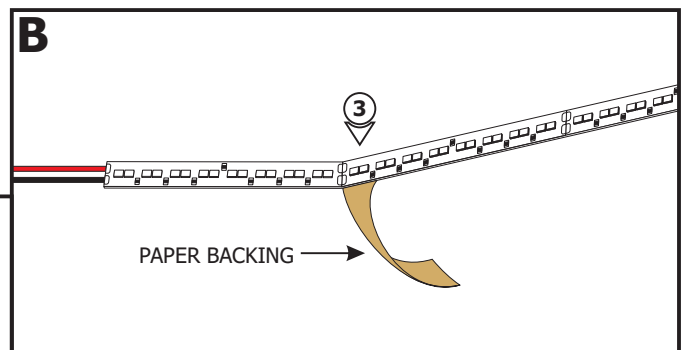

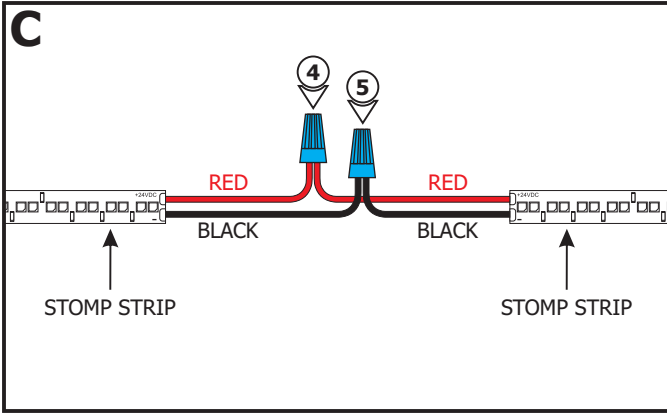

Soldered Leads, 2 ends (SE2)

- 4:** To join multiple LED strips, connect the +24VDC red wires from one end of both LED strips together using a wire nut.
- 5:** Connect the -24VDC black wires from the same ends of both LED strips together using a wire nut.
- 6:** Repeat steps 4 and 5 for additional sections.

7: Route the wires on the other end of the LED strip that are going to be connected to power to the power supply. Refer to the wiring diagrams and the instructions provided with the power supply to complete the installation.

NOTE: ST5A Stomp Strip consume on average 5 Watt per foot.

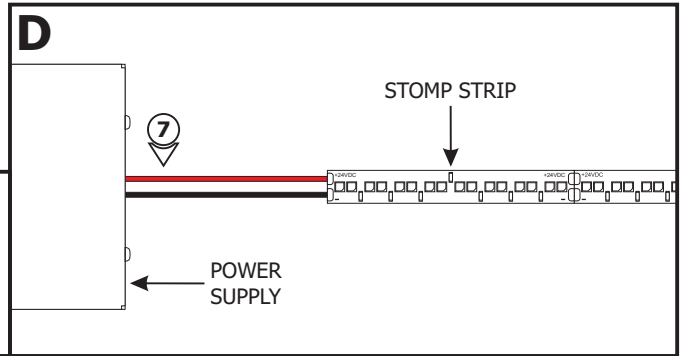

General Wiring Diagram

ELV WIRING

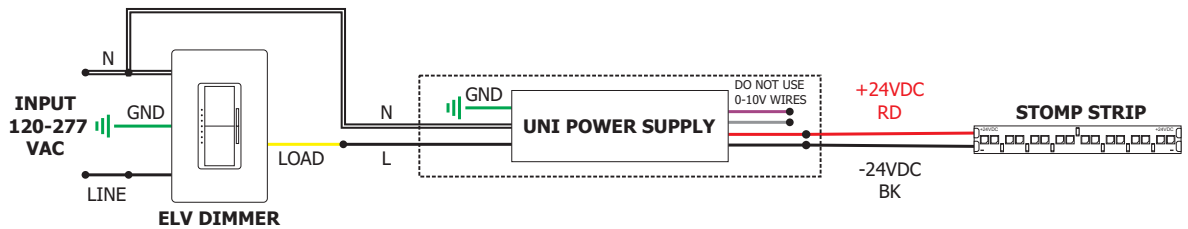

0-10V WIRING

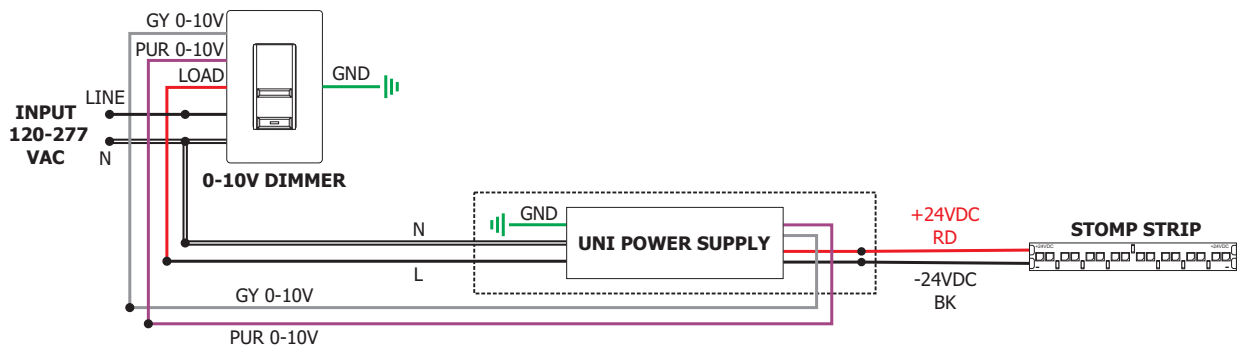

IMPORTANT INFORMATION REGARDING INSTALLATION AND REWORK OF SOFT STRIP LED

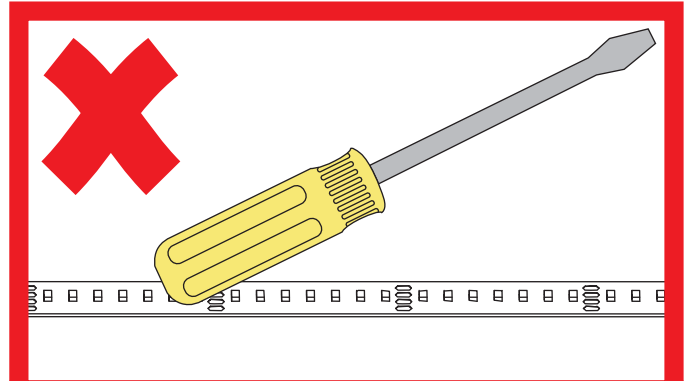
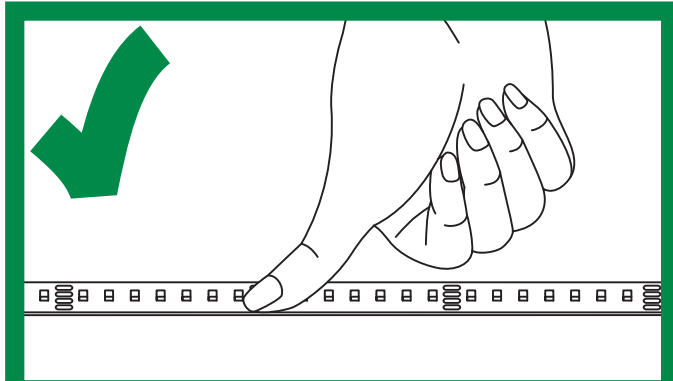
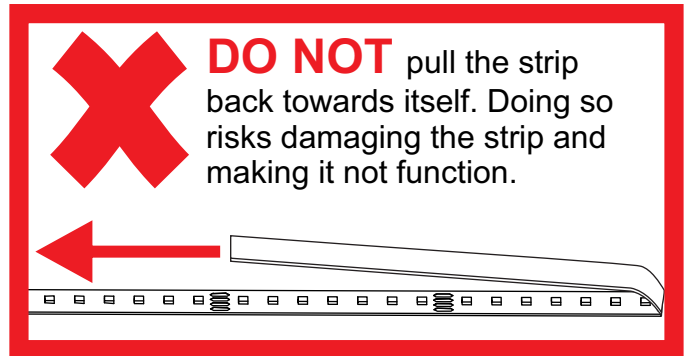
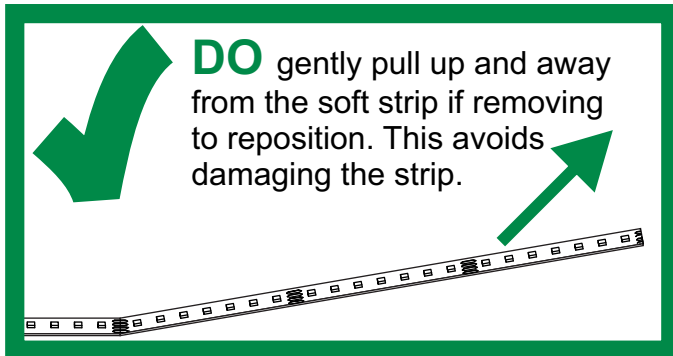

Relocating Soft Strip (Optional)

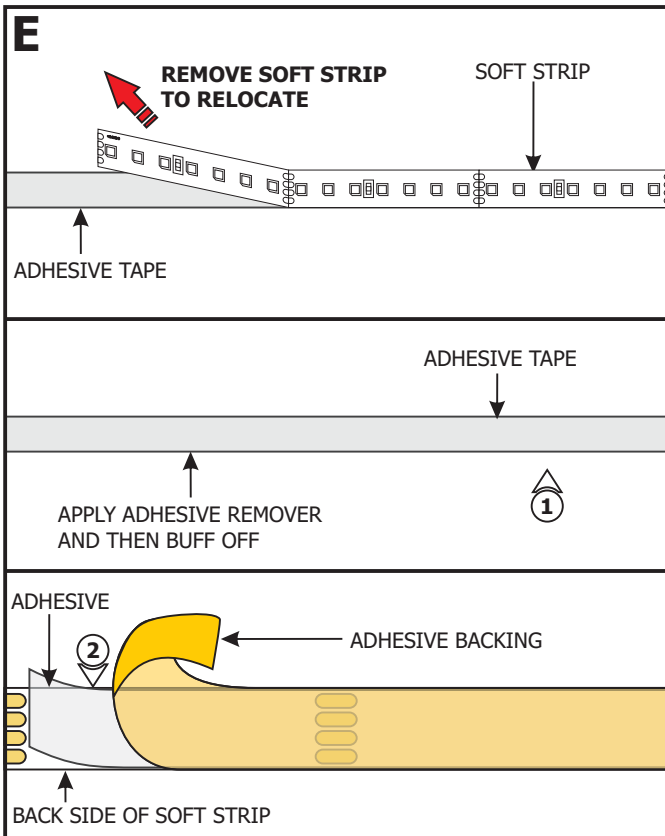

NOTE: If relocating the installed soft strip, make sure that the adhesive tape on back of the soft strip covers the entire strip. The adhesive tape isolates the strip from the installation surface. Damaged or inconsistent adhesive tape may cause the contacts on the back of the strip to come in contact with the conductive heat sink which will cause the strip to short and burn. Call PureEdge Lighting to get replacement adhesive tape and/or optional aluminum heat sink tape (SS-HR-F).

- 1:** To remove tape residue from back of the strip, apply WD-40, Goo Gone, or a mixture of warm water and lemon oil to the corner of a clean, dry towel. Gently buff the area containing the adhesive residue until it is completely removed.
- 2:** Gently remove a few inches from one side of the tape backing. Attach the adhesive tape to the back of the soft strip and apply moderate pressure to affix the tape. Continue this step a few inches at a time until the entire adhesive tape is attached to the back of the soft strip.
- 3:** Refer to step 3 to reinstall the LED strip.