



1718 W. Fullerton Chicago, IL 60614  
 Ph: 773.770.1195 • Fax: 773.935.5613  
 www.PureEdgeLighting.com • info@PureEdgeLighting.com  
 © 2016 PureEdge Lighting. All Rights Reserved.

## Installation Instructions for TruTrack End Power Feed

**TR24-1C-EP**

### IMPORTANT INFORMATION

- This product is for indoor dry locations only.
- This instructions shows a typical installation.
- Before beginning any electrical work, ensure that the power to the electrical box is off.

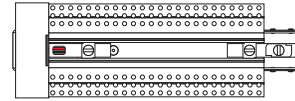
**SAVE THESE INSTRUCTIONS!**

## Section One: Install the Junction Box

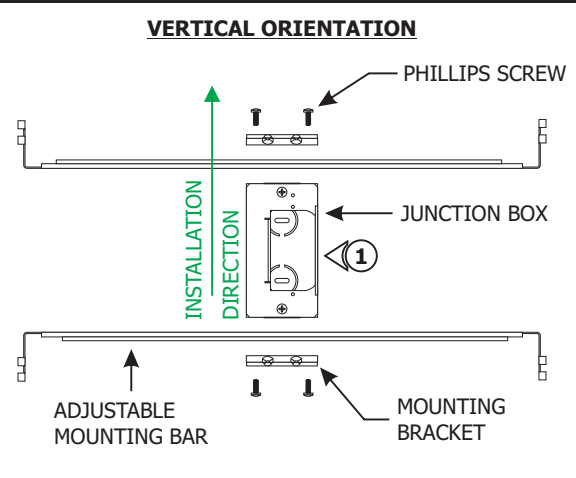
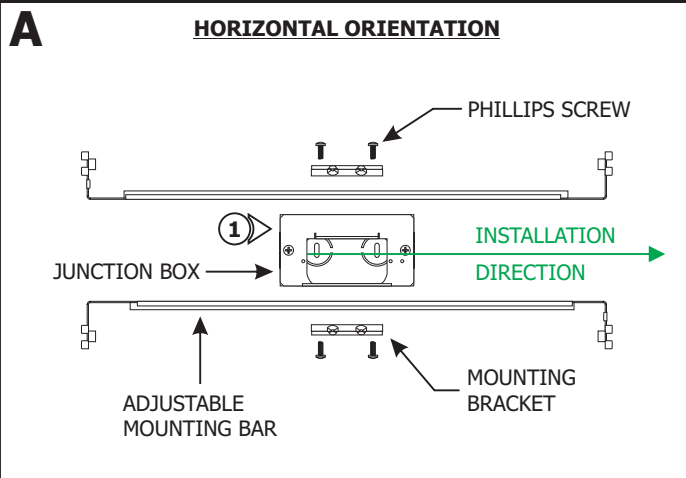

- 1:** Mount each adjustable mounting bar to one side of the junction box and secure them with the mounting brackets and Phillips screws provided.

**NOTE:** Adjustable mounting bars mount to studs that are spaced 15" to 24" apart. If the span needs to be shorter than 15", then break the bar arms from dedicated lines.

- 2:** Place the adjustable mounting bar tabs against the ceiling joists. Secure the adjustable bars to the joists with the #8 screws.

- 3:** Install conduit (if required by local electrical code) and run the 24VDC low voltage wires coming from the remote power supply to the junction box.

**NOTE:** Only use 0-10V and Uni power supplies with this product. See the wiring diagram provided with the power supply instructions.

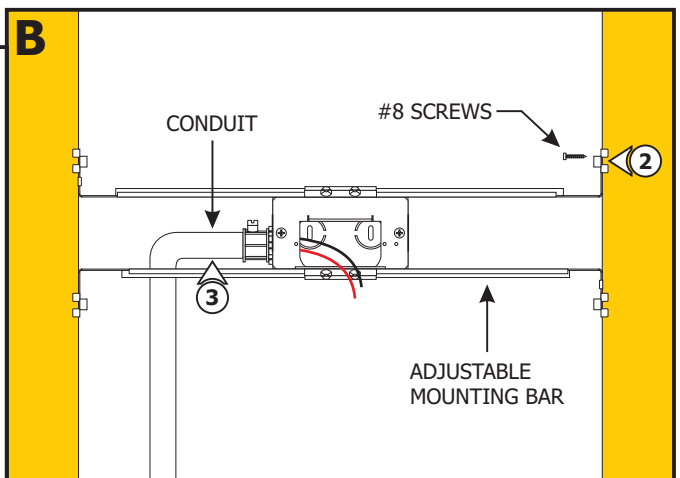

## Section Two: Install End Power Feed

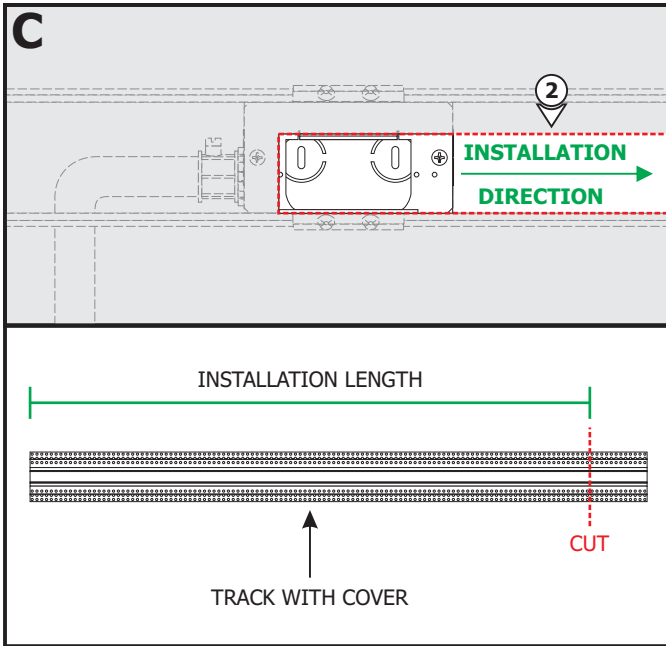

- 1: Cut a section of drywall to expose the junction box area.
- 2: Mark and cut out the area where the installation will be located using the junction box opening as a guide. Install the drywall aligning it with the junction box.

**NOTE:** Refer to the TruTrack Recessed Channel instructions to measure and cut the track and cover before continuing.

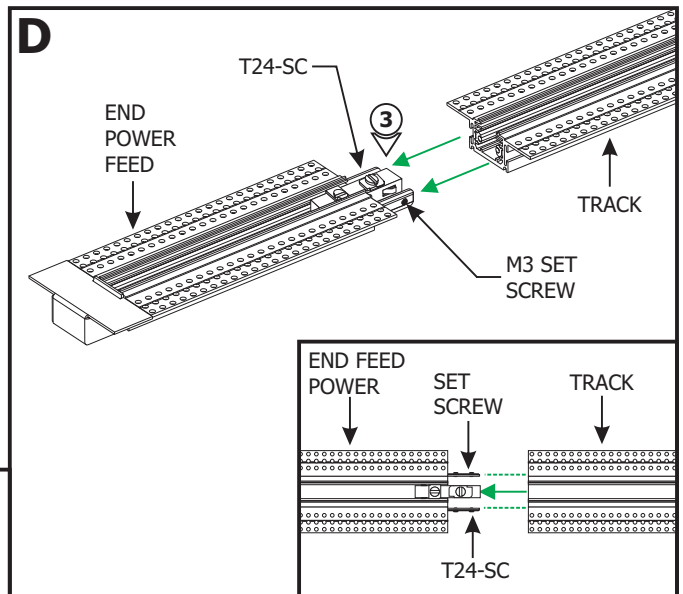

- 3: Align and slide a track over the straight connector (T24-SC) on the End Power Feed. Tighten the set screws using an Allen wrench and the slotted screw on the straight connector using a flat-head screw driver.

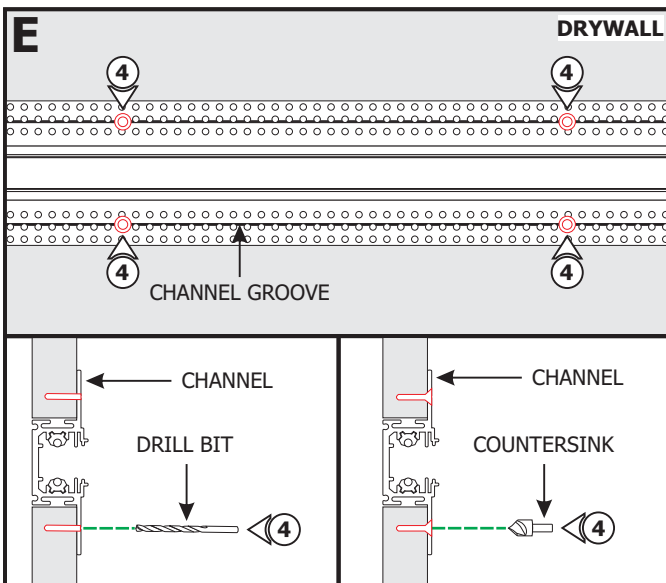

- 4: Place the assembled channel in the drywall cutout. Using the marked joist and mounting strap locations on the drywall, drill and countersink the channel along the groove lines using the provided square drill with countersink bit.

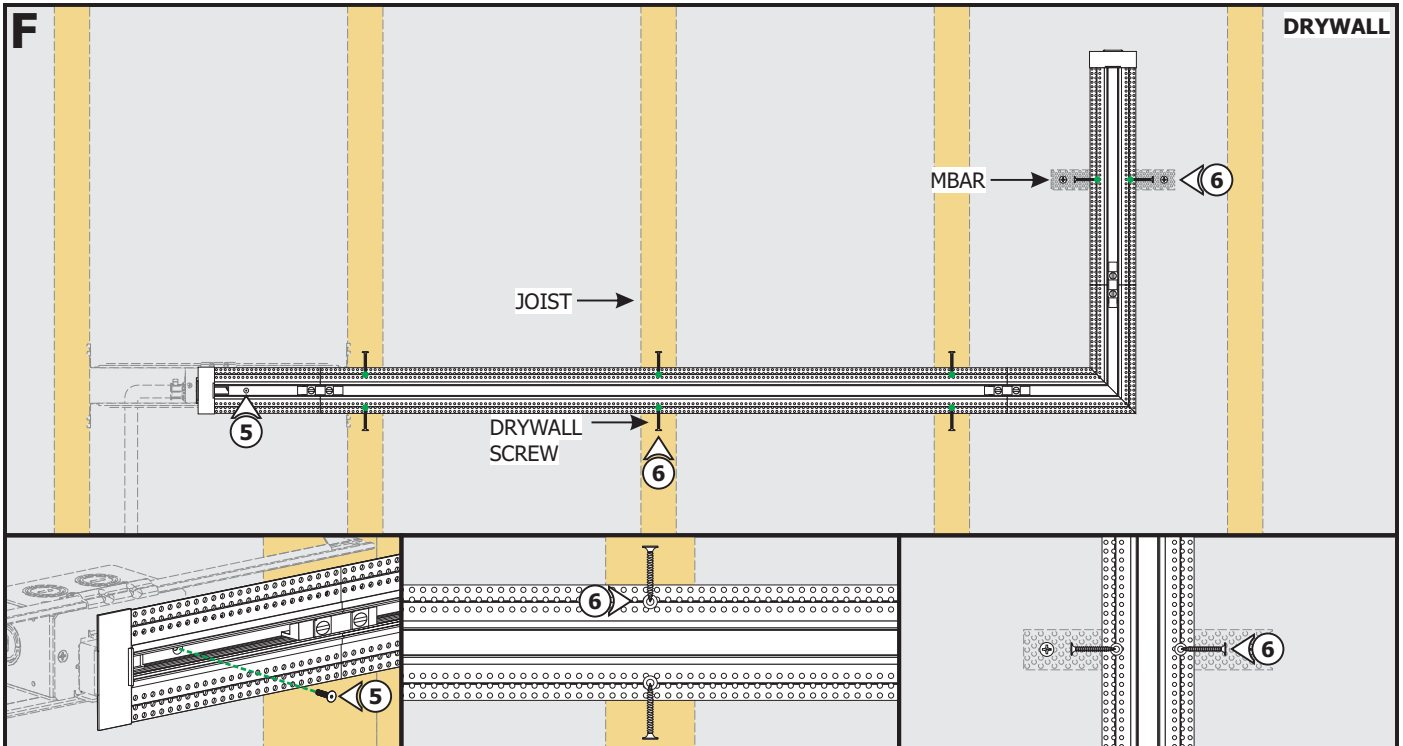

**5:** Secure the End Power Feed to the junction box with the #4-40 screw using a 1/16" Allen wrench.

**6:** Properly secure the channel to the marked joists and mounting straps using drywall screws (**DO NOT over tighten**). Ensure all screw heads are flush with the channel surface.

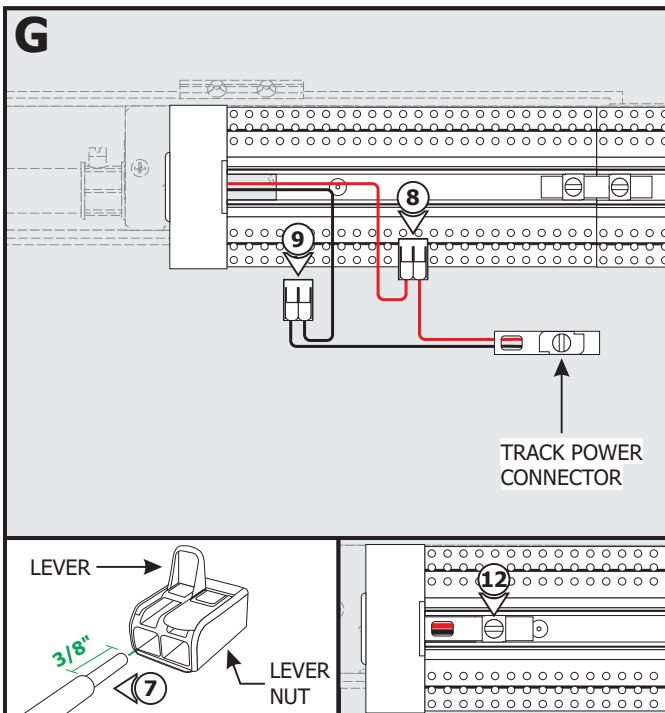

**7:** Strip 3/8" off of the Track Power Connector wires and the low voltage power supply wires.

**8:** Pull up the levers of one lever nut, and insert the red low voltage +24VDC power supply wire and the red wire of the Track Power connector. Push the levers down to connect and lock into place.

**9:** Pull up the levers of the other lever nut and insert the black low voltage -24VDC power supply wire and the black wire of the Track Power Connector. Push the levers down to connect and lock into place.

**10:** Lightly tug on the wires to ensure they are secured in place.

**11:** Place the lever nuts inside the junction box.

**12:** Place the Track Power connector inside the End Power Feed and tighten the slotted screw using a flat-head screw driver to secure in place.

**NOTE:** Refer to the TruTrack Recessed Channel instructions to plaster and complete the installation.

# General Wiring Diagrams

