



1718 W. Fullerton Chicago, IL 60614  
 Ph: 773.770.1195 • Fax: 773.935.5613  
 www.PureEdgeLighting.com • info@PureEdgeLighting.com  
 © 2016 PureEdge Lighting. All Rights Reserved.

# Installation Instructions for TruTrack Magnetic Two Circuit, Recessed 24VDC - Track Channel

TR24M-2C-\_\_

## IMPORTANT INFORMATION

- This product is for indoor dry locations only.
- This instructions shows a typical installation.
- Before beginning any electrical work, ensure that the power to the electrical box is off.

**SAVE THESE INSTRUCTIONS!**

## GENERAL INFORMATION



Scan with your mobile device for more information or visit [https://www.pureedgelighting.com/pure/products/trustrack\\_magnetic.php?bc=Products|Recessed|Recessed%20Track](https://www.pureedgelighting.com/pure/products/trustrack_magnetic.php?bc=Products|Recessed|Recessed%20Track)

## Section One: Install the Remote Power Supply

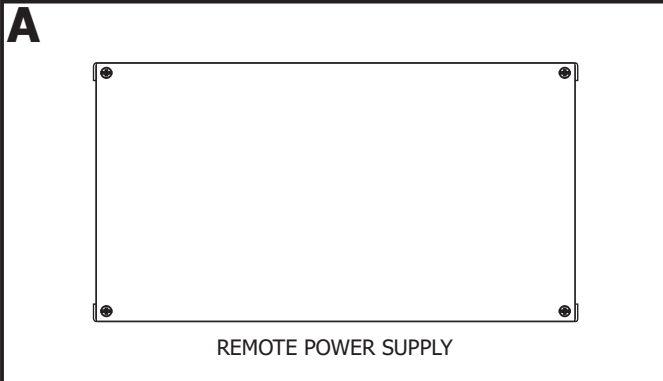

**1:** Remote power supplies must be installed within 40ft of the junction box. Refer to the instructions and wiring diagram provided with the remote power supplies.

## Section Two: Install the Junction Box

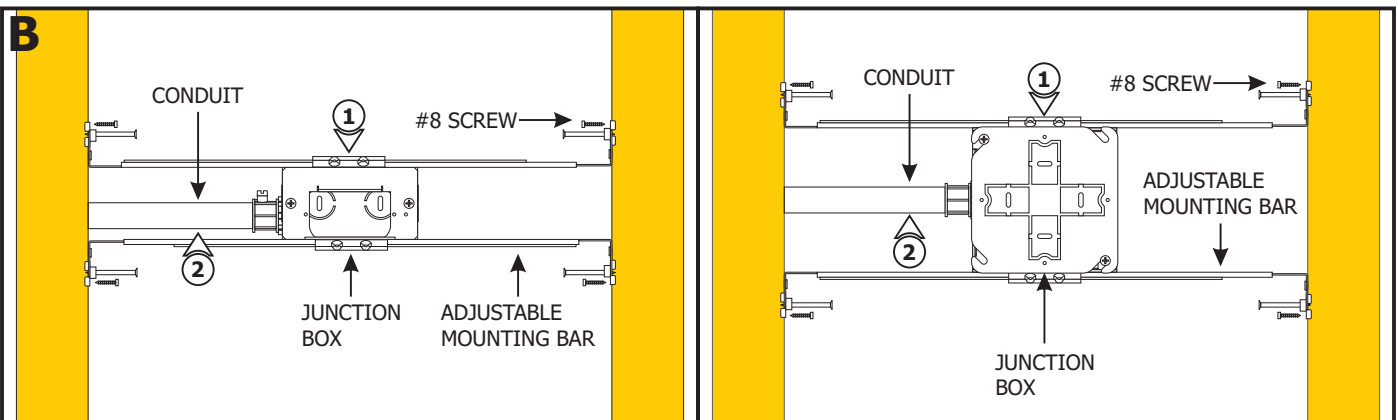

- 1:** Refer to the instructions provided with any of the TruTrack Power Feeds to install the junction box using the adjustable mounting bars. Secure the bars to the joists.
- 2:** Run the Class 2 24VDC low voltage wires coming from the remote power supplies to the junction box. Only install conduit if required by local electrical code.

## Section Three: Install and Cut Drywall for the Track Channel

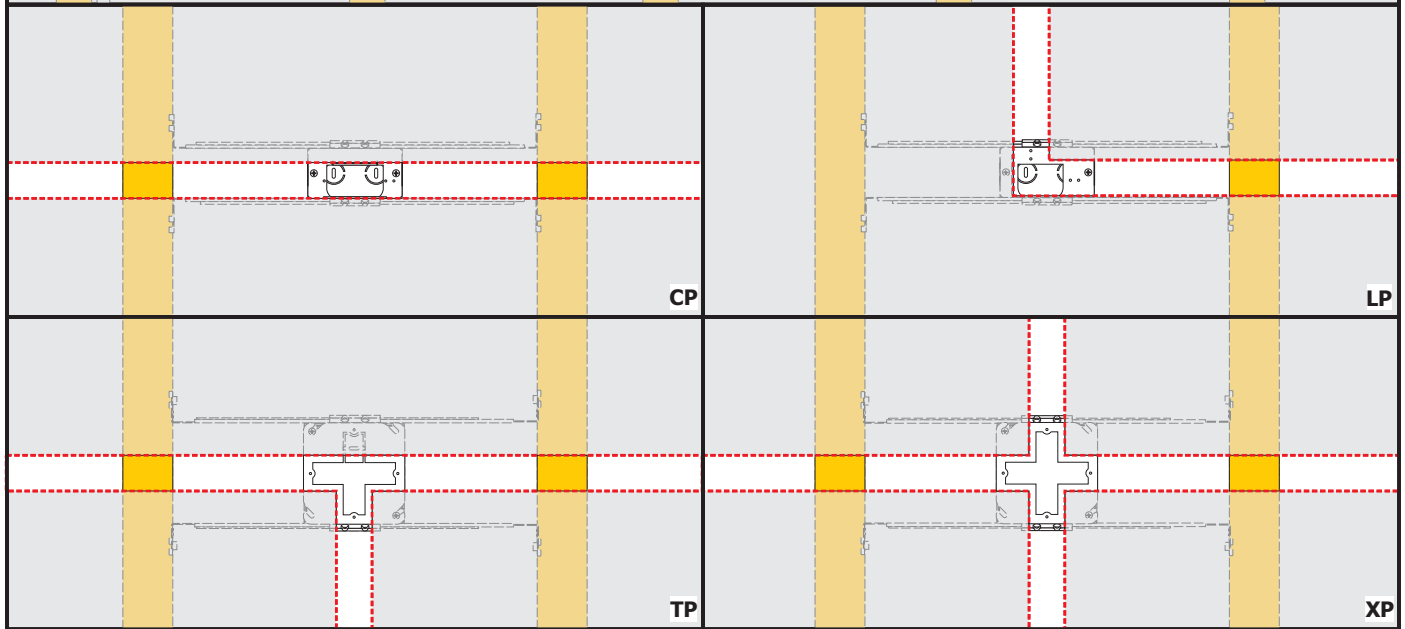
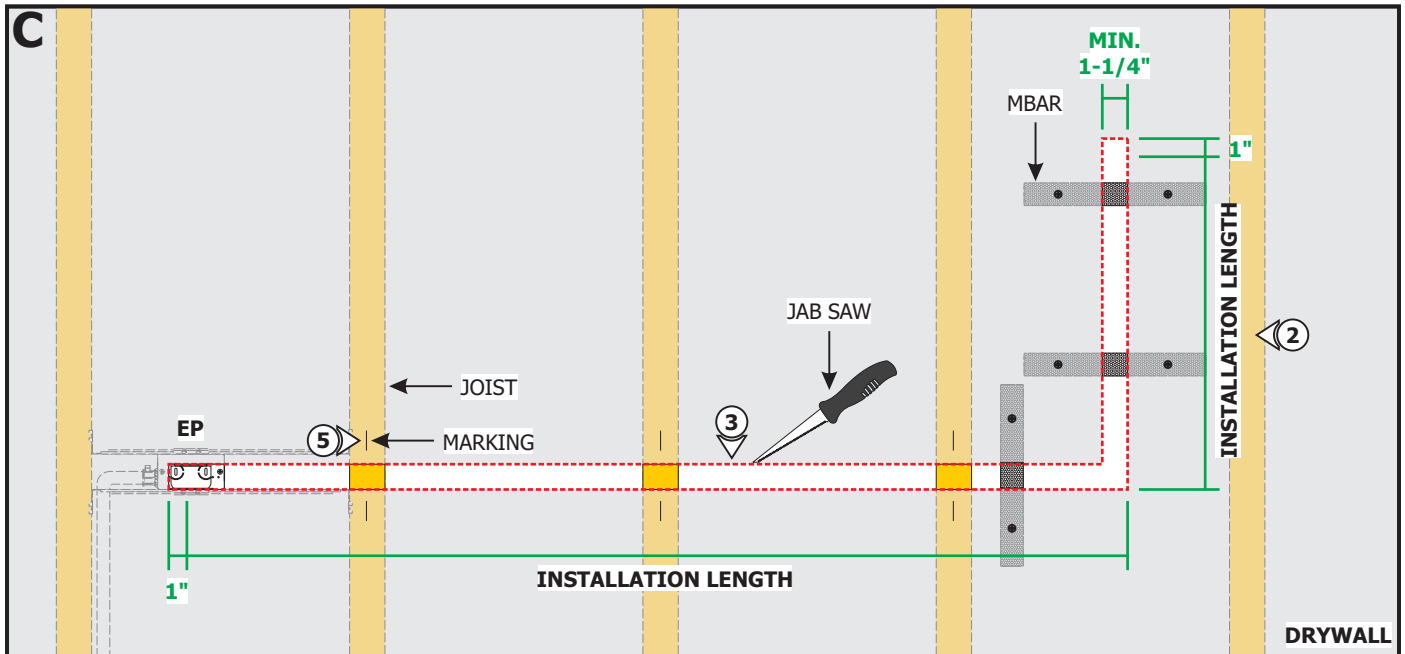

- 1:** Cut a section of drywall to expose the junction box area.
- 2:** Mark the area where the TruTrack will be located on the ceiling using the junction box opening as a guide (MIN. 1-1/4"). Allow 1" at the beginning and end of the installation for the End Caps (if any).
- 3:** Cut out the marked area on the drywall using a jab saw or other appropriate tool.
- 4:** Install the drywall aligning it with the junction box.
- 5:** Mark the location of the joists and mounting straps (MBAR) to the drywall for future reference.

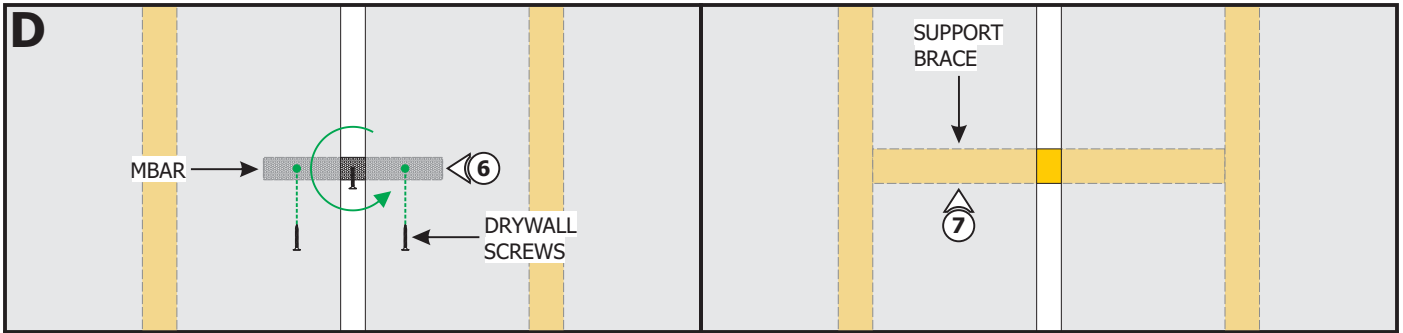

**NOTE:** To install the track in a wall without standard-spaced joists, install perforated mounting straps (**MBAR**) every 32" behind drywall.

**NOTE:** For areas with lots of vibrations, it is suggested to install 2X4 support braces (suggested spacing is every 32") before installing and finishing drywall to avoid cracking of plaster. Refer to the step 7, Alternate Installation Option.

**Additional Mounting Support:**

**6:** Thread a drywall screw into the perforated material. Use the screw to hold and place the mounting strap (**MBAR**) behind the drywall, and then rotate it in place. Secure the mounting strap to the drywall using two drywall screws. Mark the location of the mounting strap on the drywall.

**Alternate Installation Option:**

**7:** Install 2X4 support braces (suggested spacing is every 32") before installing and finishing drywall.

## Section Four: Install Track Channel and Connectors

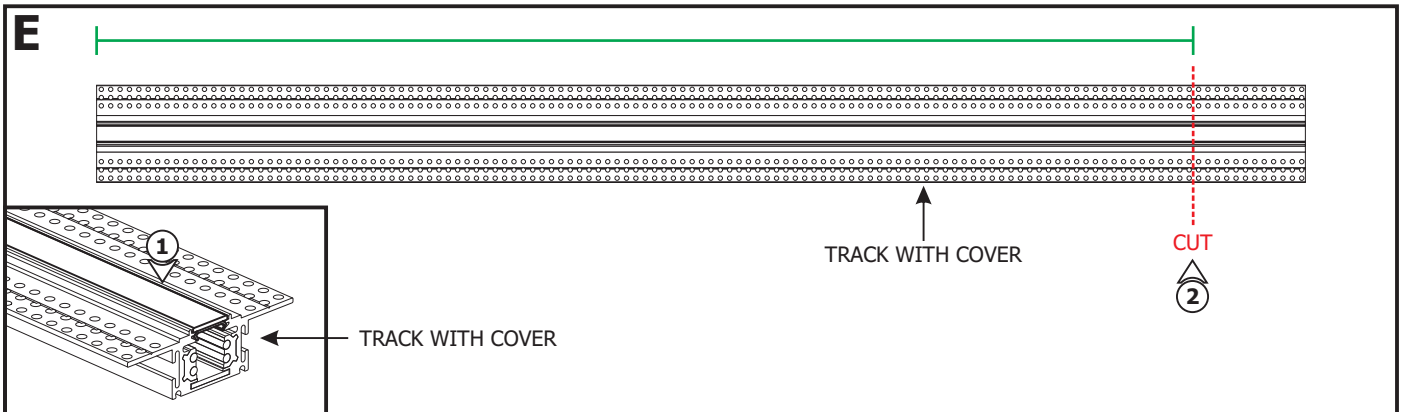

**1:** Remove the spare cover inside the track. One cover is used for plastering and is disposed after painting. The second cover is for the final clean installation. Snap one of the covers onto the track **BEFORE** cutting to length. This ensures a proper fit after installation.

**2:** Use a miter circular saw to cut the track channel and cover to match the installation length. Remove the cover.

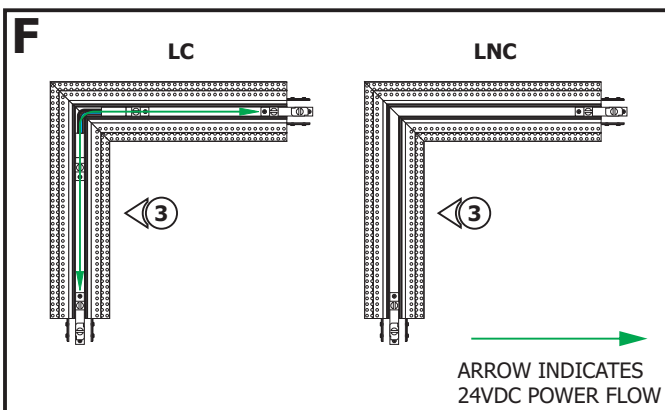

**3:** L-Connectors join two track sections together in a 90 degree angle and either conduct the power from one track to the other (**LC**) or isolate the power from one track to the other respectively (**LNC**).

**4:** Refer to the instructions provided with the L-Connector.

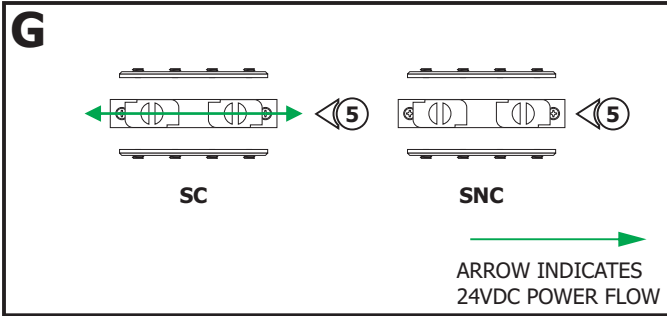

**5:** Straight connectors join two track sections end to end and either conduct the power from one track to the other (**SC**) or isolate the power from one track to the other respectively (**SNC**).

**6:** Insert the joining connectors half way into the track and tighten the M3 set screws using a 1.5mm Allen wrench.

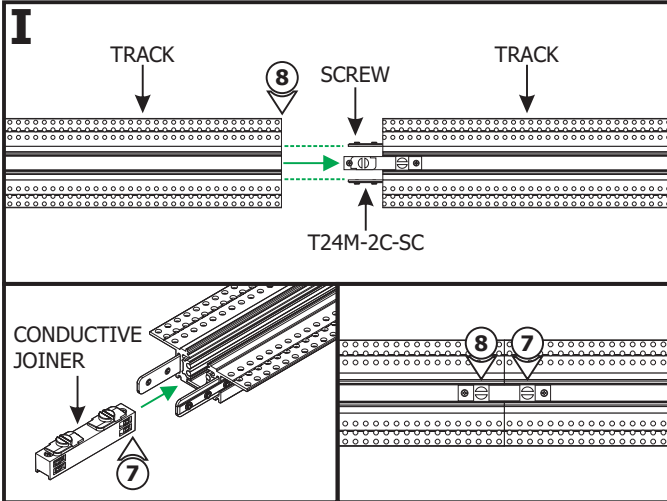
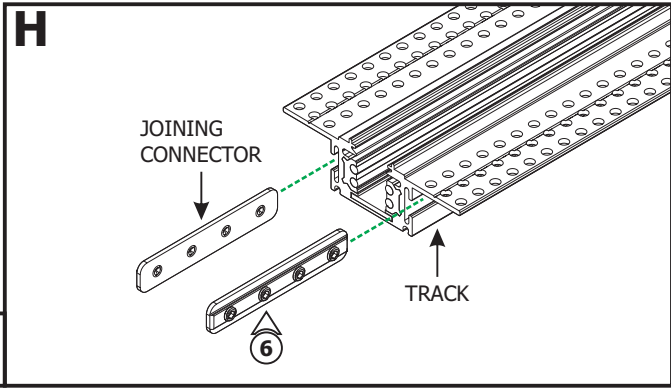

**7:** Insert the conductive joiner half way into the end of the track. Tighten the slotted screw using a flat-head screw driver.

**8:** Slide a track over the joining connectors and conductive joiner. Tighten the remaining screws and slotted screw.

**9:** Loosen (**Do Not Remove**) the two M3 set screws on the End Cap using a 1.5mm Allen wrench.

**10:** Slide the End Cap into the non-power end of the track and tighten the two M3 set screws using a 1.5mm Allen wrench to secure in place.

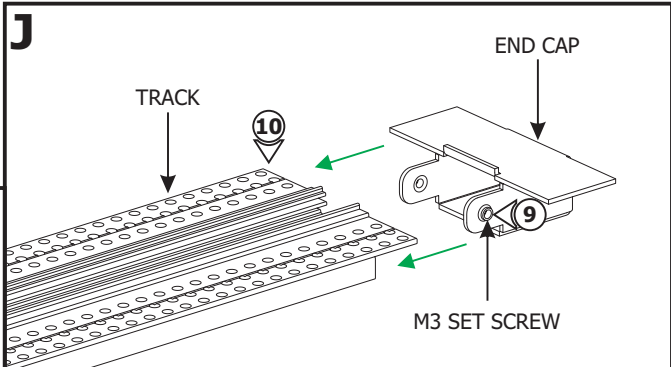

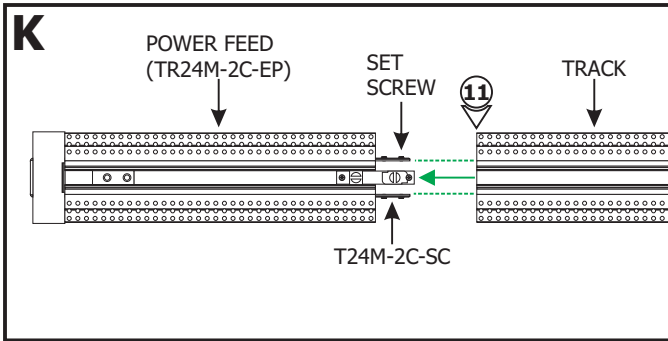

**NOTE:** End Power Feed (TR24M-2C-EP) is shown for demonstration purposes.

**11:** Refer to the instructions provided with the TruTrack Power Feeds to connect to the tracks.

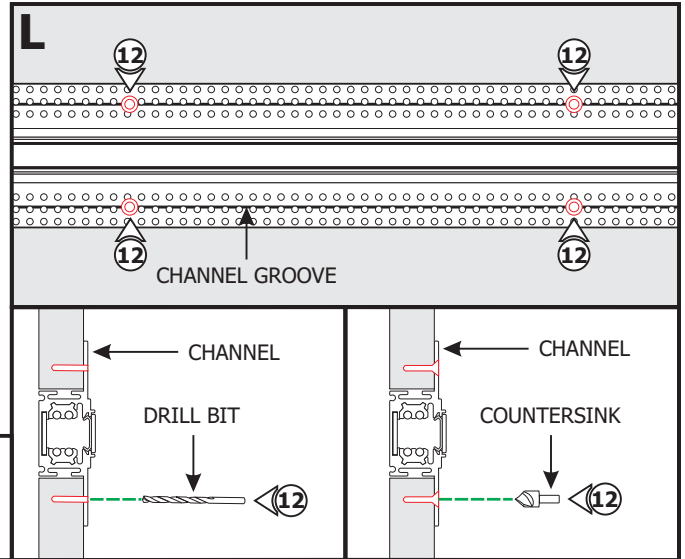

**12:** Place the assembled channel in the drywall cutout. Using the marked joist and mounting strap locations on the drywall, drill and countersink the channel along the groove lines using the provided square drill with countersink bit.

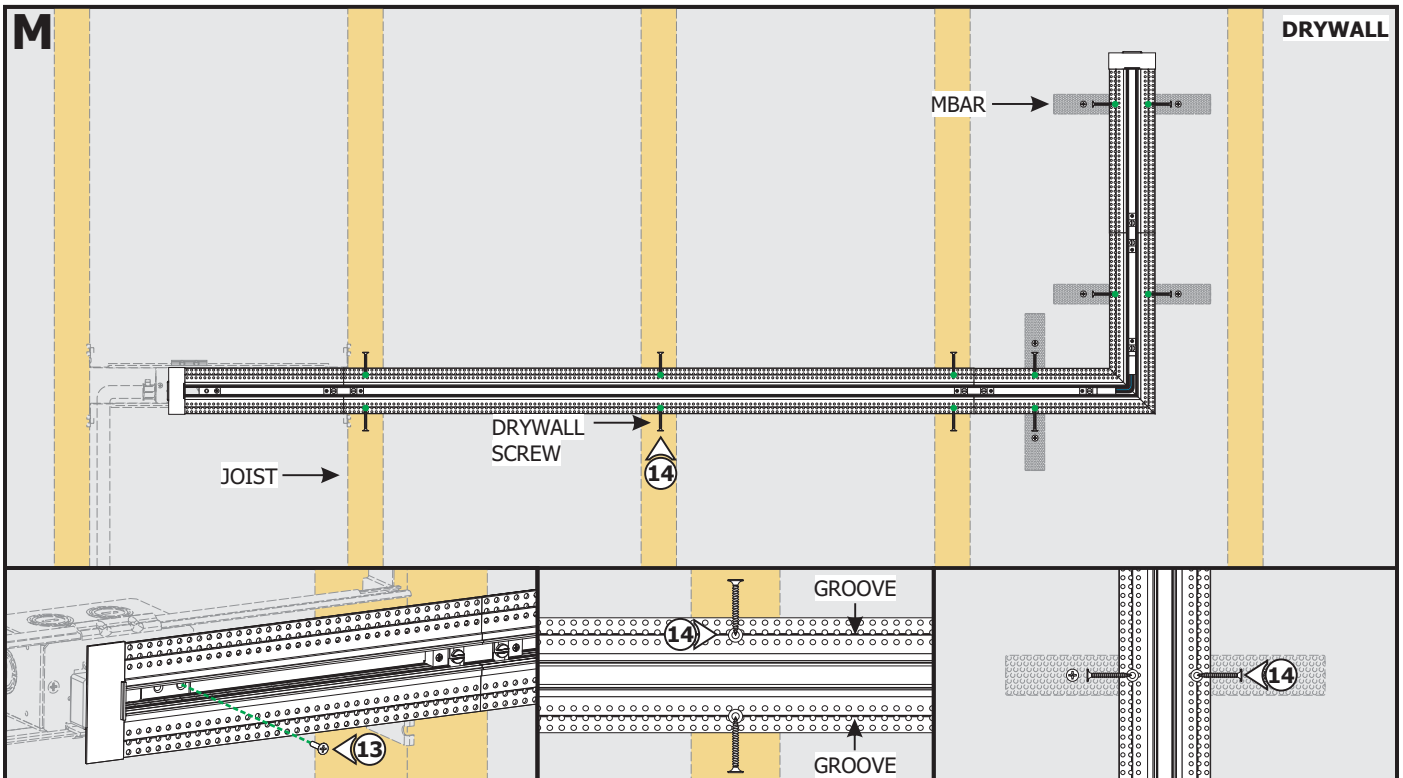

**13:** Secure the TruTrack Power Feed to the junction box with the provided screw(s).

**14:** Properly secure the channel to the marked joists and mounting straps using drywall screws (**DO NOT over tighten**). Ensure all screw heads are flush with the channel surface.

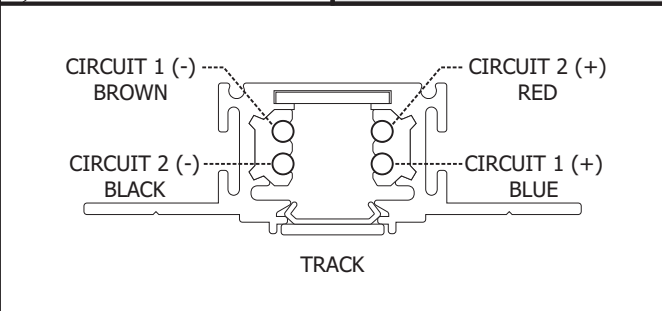
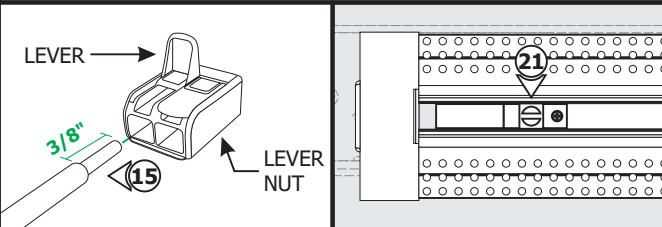
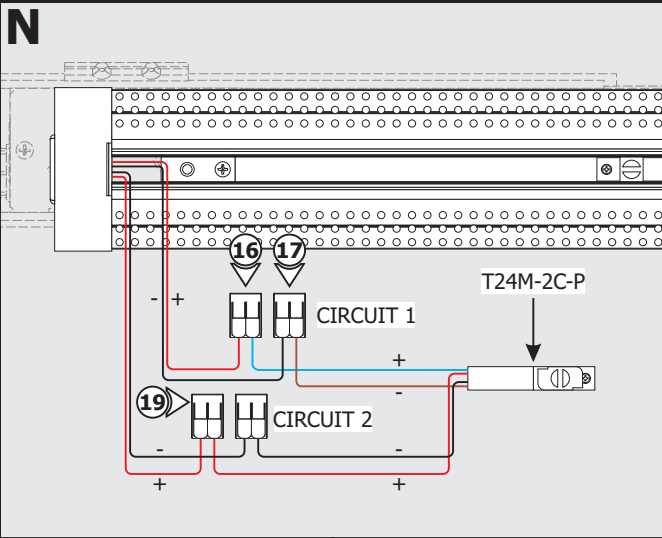

- 15:** Strip 3/8" off of the Power Feed Connector (**T24M-2C-P**) wires and the low voltage power supply wires.
- 16:** Pull up the levers of one lever nut and insert the low voltage +24VDC power supply wire and the Circuit 1 +24VDC blue wire of the Power Feed Connector. Push the lever down to connect and lock into place.
- 17:** Pull up the levers of the other lever nut and insert the low voltage -24VDC wire from the same power supply and the Circuit 1 -24VDC brown wire of the Power Feed Connector. Push the lever down to connect and lock into place.
- 18:** Lightly tug on the wires to ensure they are secured in place.
- 19:** Repeat steps 15 through 18 to connect the Circuit 2 +24VDC red wire and -24VDC black wire to the +24VDC wire and -24VDC wire of the other power supply respectively.
- 20:** Place the lever nut connections inside the junction box.
- 21:** Place the Power Feed Connector inside the track and tighten the slotted screw with a flat-head screw driver to secure in place.

**CAUTION: Test the circuits using a track head before plastering.**

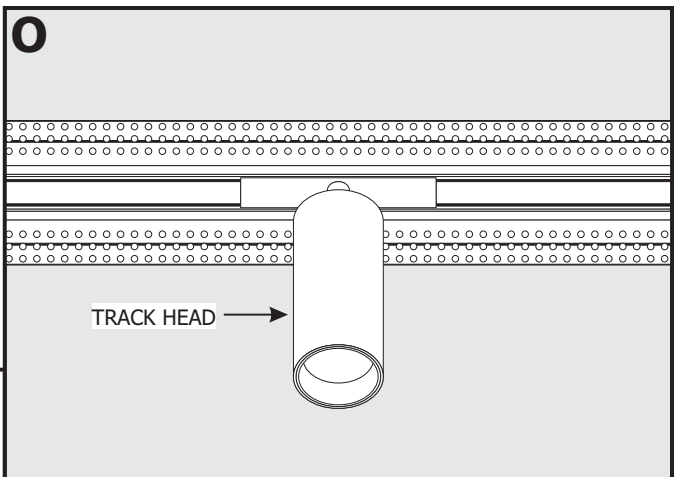

## Section Five: Plaster, Sand and Paint

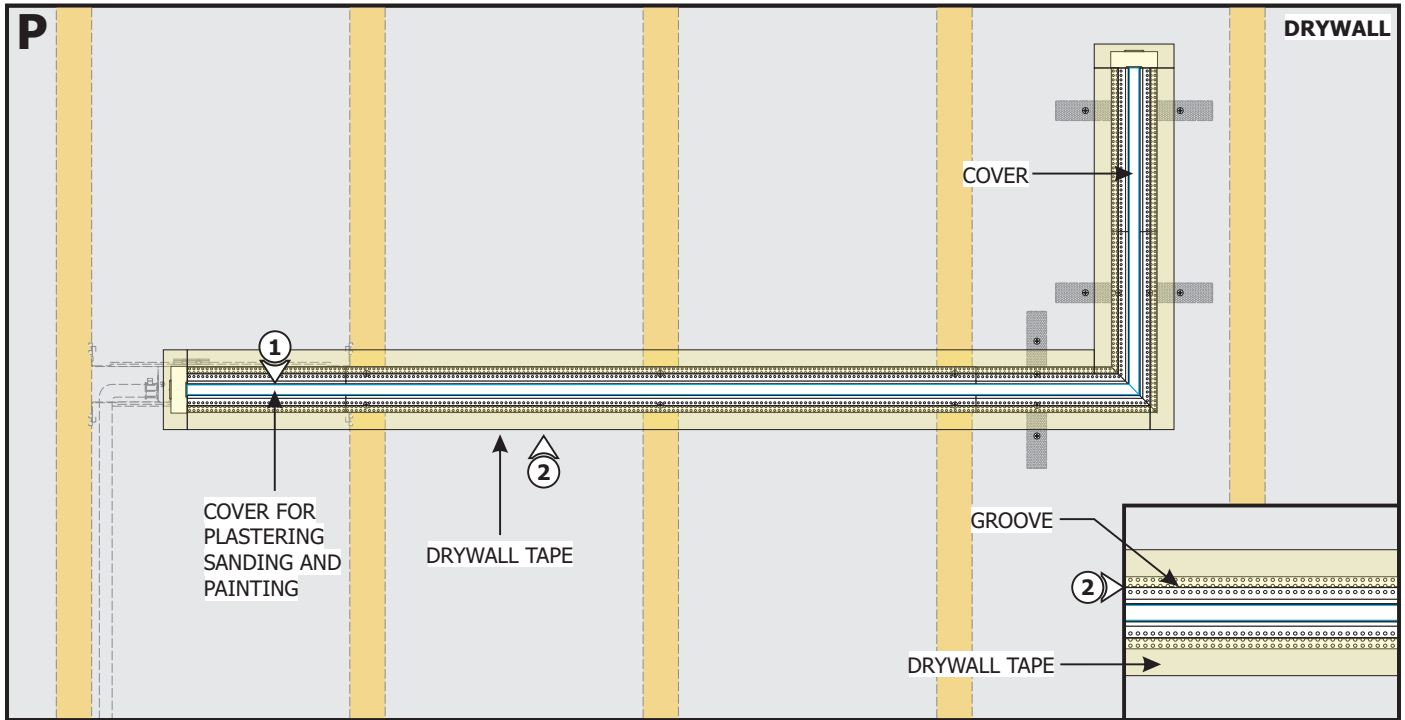

**NOTE:** For areas with lots of vibrations, it is suggested to use Durabond to avoid cracking of plaster.

**NOTE:** **Do Not** use premixed joint compound "Soft Mud." No use compuesto para juntas premezclado "Soft Mud."

**NOTE:** Recommended plaster method: 1st Coat - Durabond 45 with 8" Blade, 2nd Coat - Easy Sand 45 with 10" Blade, 3rd Coat - with 12" Blade

**1:** Snap the cover for plastering, sanding and painting onto the track.

**2:** Must apply drywall tape (Ultra-Thin drywall tape suggested) along edges of the track up to the groove to prevent cracking of plaster after installation. **DO NOT** overlap strips of drywall tape.

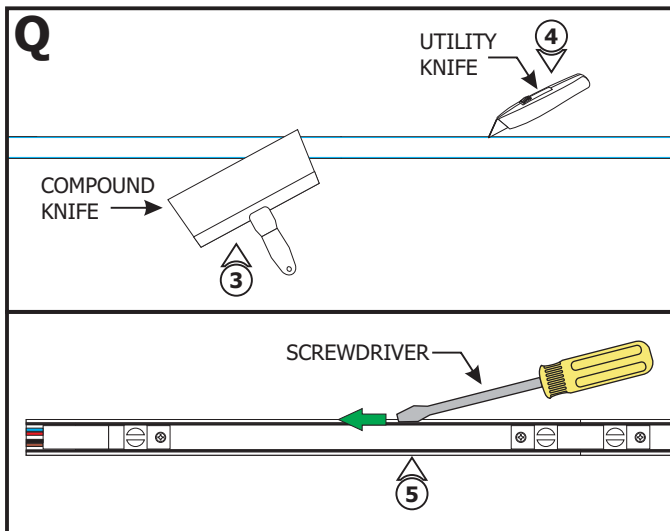

**3:** Use a 12" compound knife for a smooth compound spread. Plaster and sand the drywall.

**4:** Use a utility knife to cut along the track gutter. This will avoid plaster damage during cover removal.

**5:** Remove the cover. Carefully use a small flathead screwdriver to clean and remove excess drywall from the internal bevel/edge along the track.

**6:** Clean the channel surface with alcohol to remove any dust or debris.

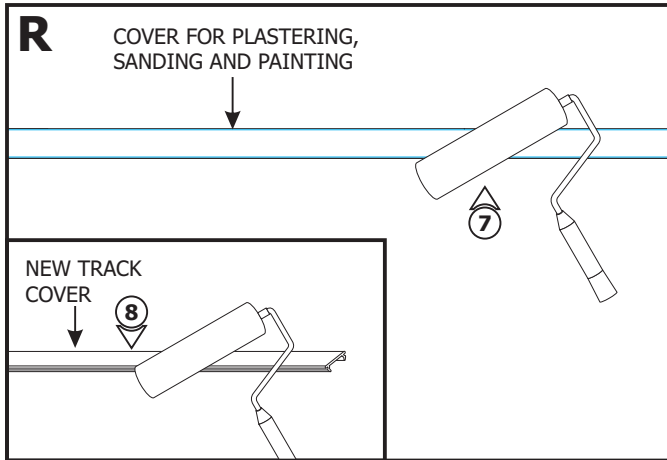

**7:** Replace the removed track cover back (using it as masking tape) and finish painting the drywall. After painting, wait 1 hour and remove the track cover before the paint dries and discard it.

**8:** If necessary, cut and paint the new track cover to match the drywall paint.

**9:** After plastering, sanding and painting, clean the inside of the track with a cloth.

## Section Six: Install LED Soft Strip (Optional)

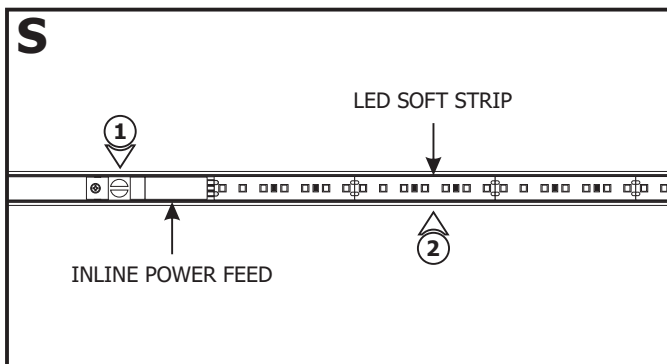

**NOTE:** Soft Strip may not properly adhere to channel surface unless the channel is cleaned with alcohol prior to application.

**1:** Use the Soft Strip Inline Power Feed to add LED Soft Strip anywhere along the track on one circuit. The Track Head and Soft Strip on the same circuit will be controlled with the same switch.

**2:** Refer to the instructions provided with the Soft Strip Inline Power Feed to install the LED Soft Strip and Lens.

## Section Seven: Install Track Heads

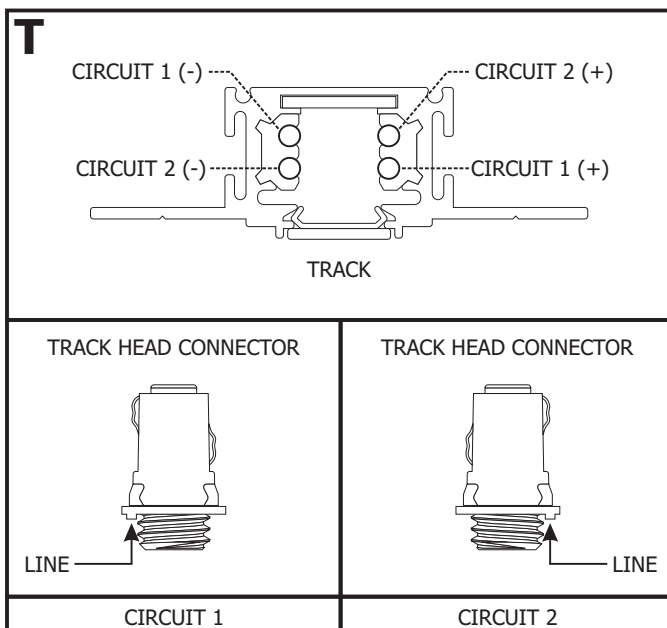

**1:** Identify the line on the Track Head Connector Cover that denotes Circuit 1 or Circuit 2. Choose Circuit 1 or Circuit 2 to power the track head fixture by rotating the track head connector 180 degrees.



**U**

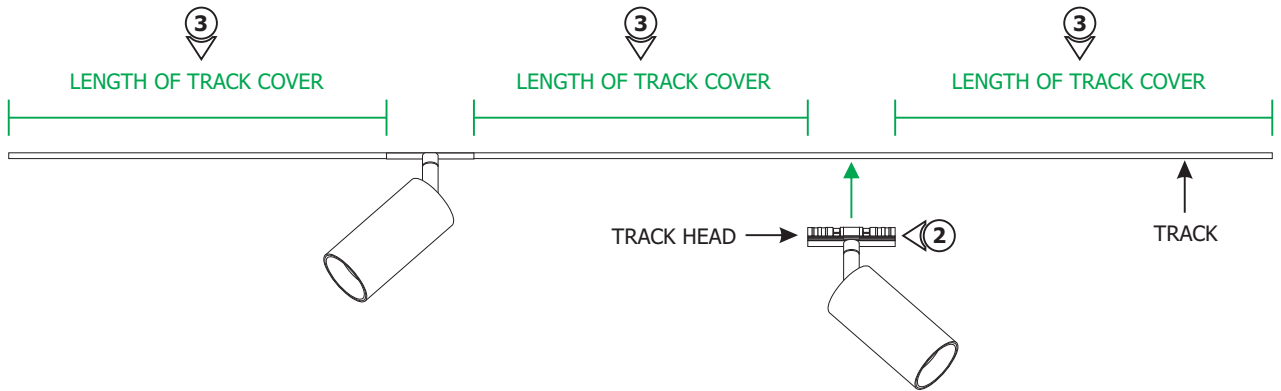

**2:** Place the track head fixtures to the desired location (refer to the instructions provided with the track head fixture).

**3:** Measure the distance between each track head fixture and cut the track cover (optional) to desired length. Snap the covers onto the track.

**NOTE:** Refer to the instructions provided with the track head fixture to complete installations.