



1718 W. Fullerton Chicago, IL 60614
 Ph: 773.770.1195 • Fax: 773.935.5613
 www.PureEdgeLighting.com • info@PureEdgeLighting.com
 © 2016 PureEdge Lighting. All Rights Reserved.

Installation Instructions for **Vanishing Point 24 Volt Drywall Plaster-In Fast Jack Connection** V_-FJ24_-

IMPORTANT INFORMATION

- This instruction shows a typical installation.
- This product is ceiling mount.

SAVE THESE INSTRUCTIONS!

Section One: Install the Junction Box

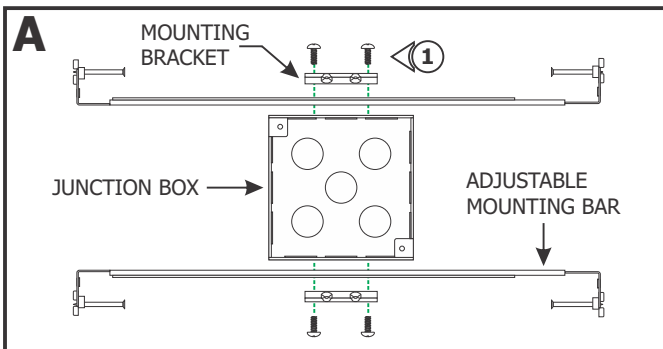

- 1:** Mount each adjustable mounting bar to one side of the junction box and secure them with the mounting brackets and two Phillips screws provided.

NOTE: Adjustable mounting bars mount to studs that are spaced 14.5" to 25" apart.

- 2:** Select the location between the two studs for the junction box to be mounted.
- 3:** Place the adjustable mounting bar tabs between the studs. Secure the adjustable bars to the studs with the #8 screws.
- 4:** Pinch anywhere on the inner edge of the mounting bars to lock in place.

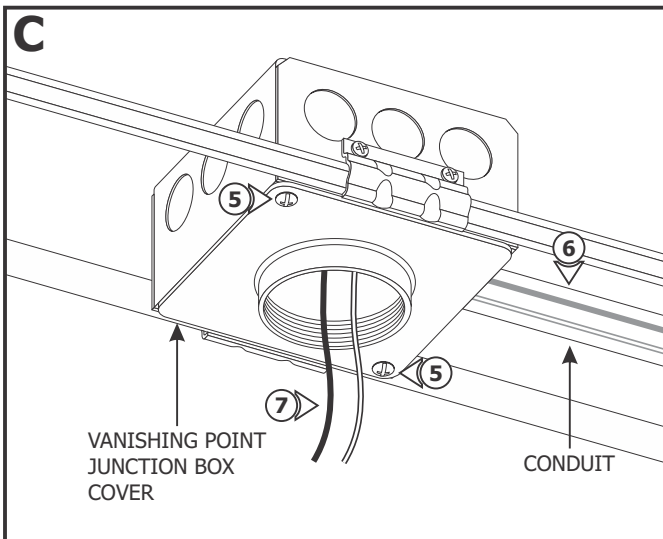
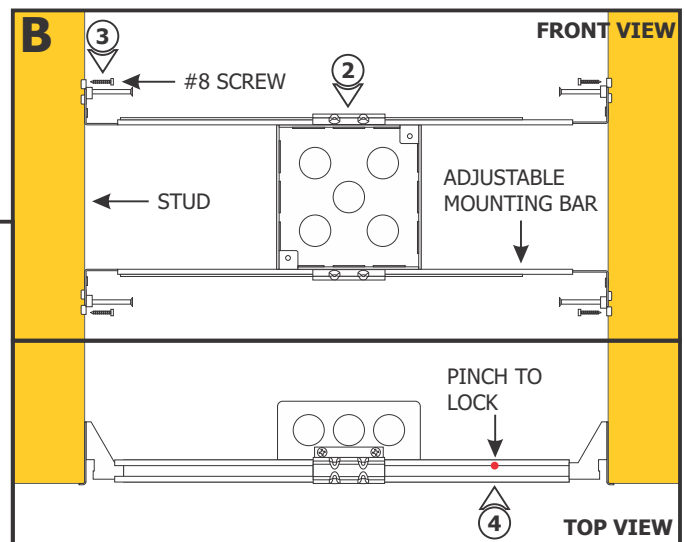

- 5:** Install the Vanishing Point junction box cover to the junction box using two #8-32 screws.
- 6:** Remove a knockout to install a conduit into the junction box. Install conduit(s) (if required by local electrical code).
- 7:** Run the line voltage wires to the junction box.
- 8:** If using remote power supply, then run the low-voltage 24V wires coming from the remote power supply to the junction box.

NOTE: Ensure remote power supply wires are present in the junction box. Refer to instructions provided with the power supply.

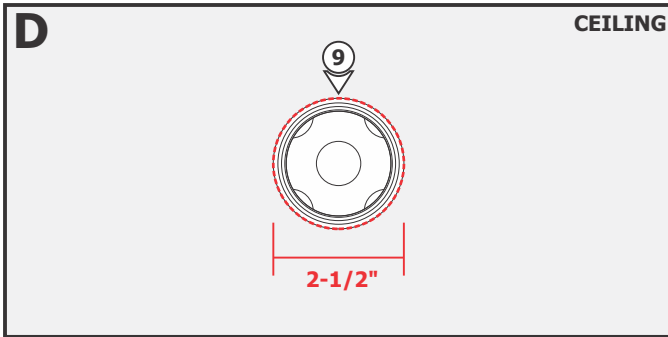

- 9:** Use a 2-1/2" hole saw to cut out the drywall section where the junction box opening is located.
- 10:** Install the drywall. If necessary, plaster and finish the drywall.

Section Two: Install the Fixture

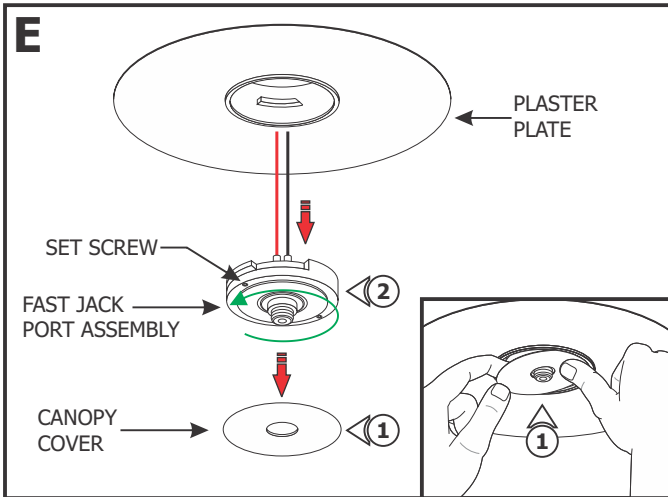

- 1:** Use fingers to push on the perimeter of the canopy cover until it slightly rocks and lift the cover to remove it from the assembly.
- 2:** Loosen (**Do Not Remove**) the #4-40 set screws on the Fast Jack Port assembly using a 0.05" Allen wrench and rotate the Fast Jack Port assembly counter clockwise to remove from the Plaster Plate.

- 3:** Screw the plaster plate clockwise into the junction box cover, ensuring the plate is tight.
- 4:** If the drywall is 5/8" thick, tighten the bottom #4-40 set screw inside the plaster plate using a 0.05" Allen wrench.
- 5:** If the drywall is 3/4" and thicker, tighten the top #4-40 set screw inside the plaster plate using a 0.05" Allen wrench.

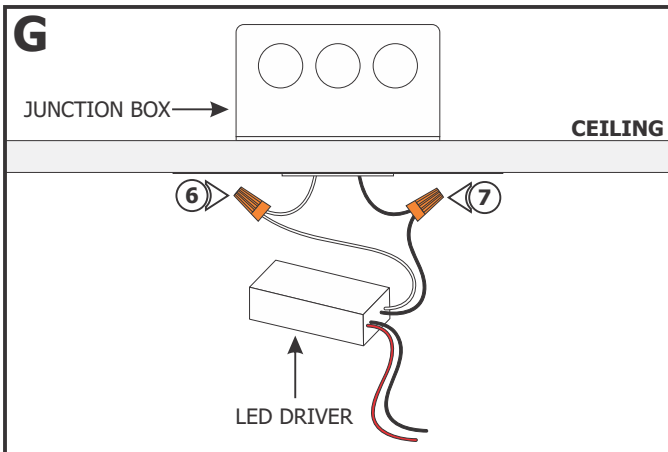
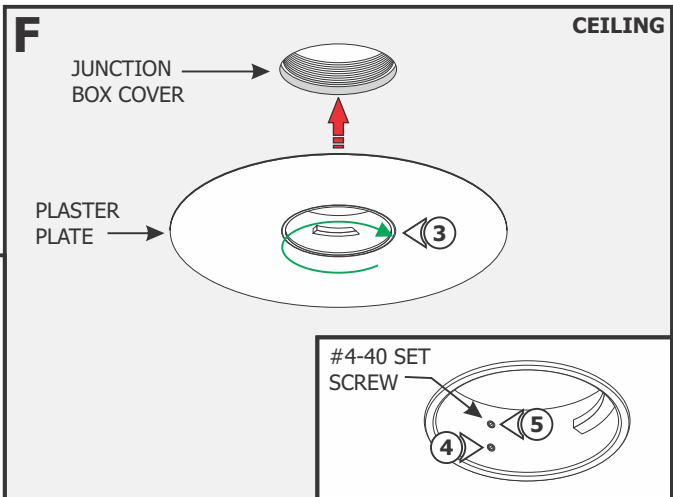

- NOTE:** Steps 6 through 8 are for the 24V power supply included inside the junction box. Omit these steps if using remote power supply.
- NOTE:** Make sure the junction box is grounded in accordance to local electrical codes.
- 6:** Connect the white LED driver wire to the neutral power wire with a wire nut.
- 7:** Connect the black LED driver wire to the hot power wire with a wire nut.
- 8:** Place the LED driver and wire nut connections inside the junction box.

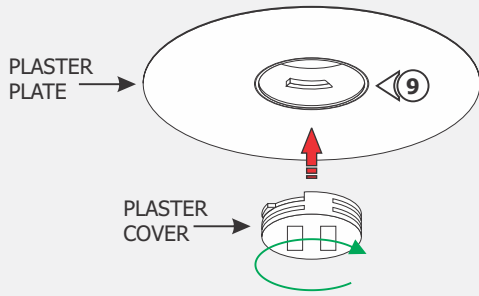
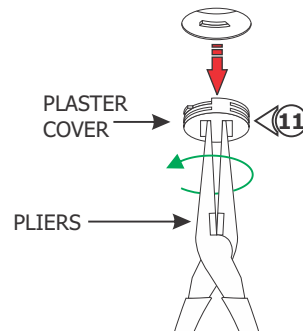
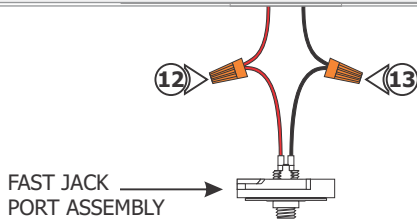
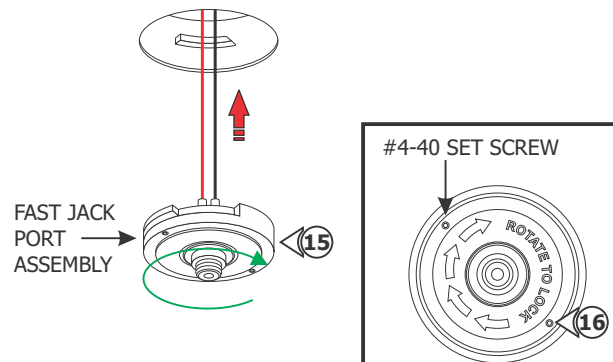
H**CEILING****9:** Rotate the plaster cover clockwise into the plaster plate.**10:** Plaster, sand and paint the surface.**NOTE:** For areas with lots of vibration, it is suggested to use Durabond to avoid cracking of plaster.**NOTE:** **Do Not use premixed joint compound "Soft Mud."**
No use compuesto para juntas premezclado "Soft Mud."**NOTE:** Recommended plaster method: 1st Coat - Durabond 45 with 8" Blade, 2nd Coat - Easy Sand 45 with 10" Blade, 3rd Coat with 12" Blade**I****11:** Use pliers to rotate the plaster cover counter clockwise and remove it. Clean the hole.**J****12:** Connect red wire of the Fast Jack Port assembly to the +24VDC power supply wire using a wire nut.**13:** Connect the black wire of the Fast Jack Port assembly to the -24VDC power supply wire using a wire nut.**14:** Place all wire nut connections inside the junction box.**15:** Insert the Fast Jack Port assembly into the opening and rotate clockwise to lock in place.**16:** Tighten the #4-40 set screws using a 0.05" Allen wrench to secure in place.**NOTE:** Test the fixture.**K**

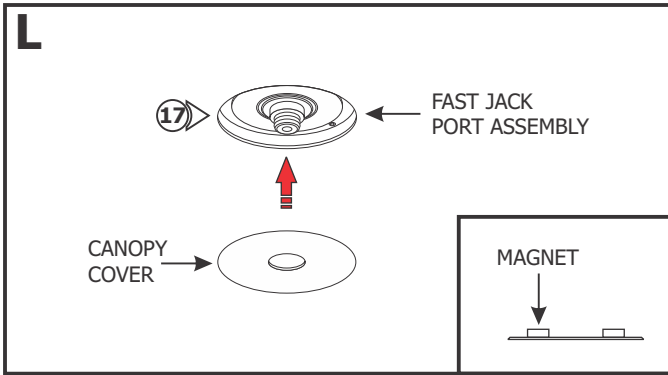

17: Place the canopy cover over the Fast Jack Port assembly. The magnets on the back will keep the canopy cover in place.

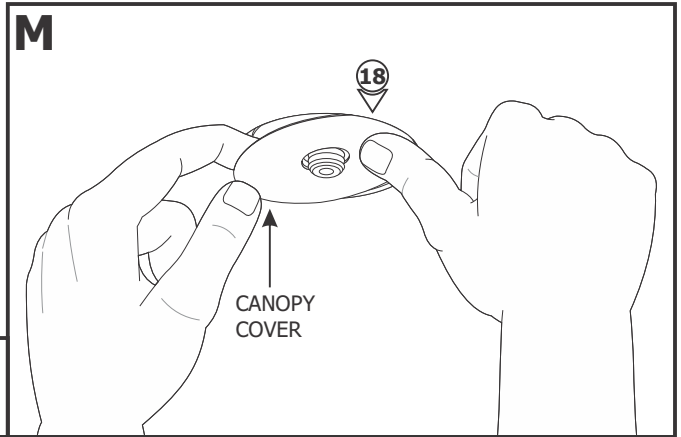

18: If necessary, use fingers to push on the perimeter of the canopy cover until it slightly rocks and lift the cover to remove it from the assembly.

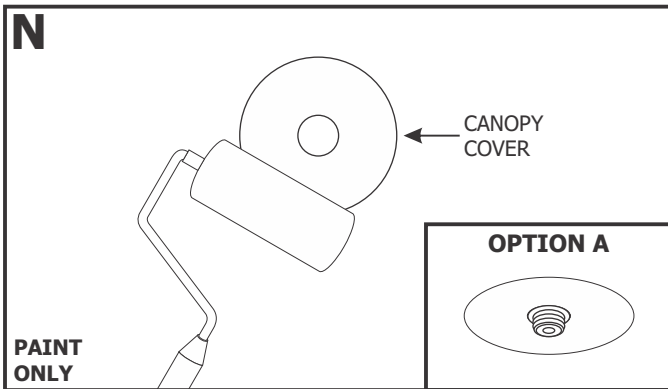

19: Choose one of the two options to cover the canopy.

Option A: For a slight outline of the canopy, prime and paint the canopy cover on the ground or table. Ensure paint is dry before replacing canopy cover over the Fast Jack Port assembly.

NOTE: Option B is recommended for remote power supply only.

Option B: For no outline of the canopy, cover the threads of the Fast Jack Port with contractor's tape. Plaster, sand and paint over the canopy cover and surface.

NOTE: If using metal tools to apply plaster, be careful not to remove the magnetic canopy cover while plastering.

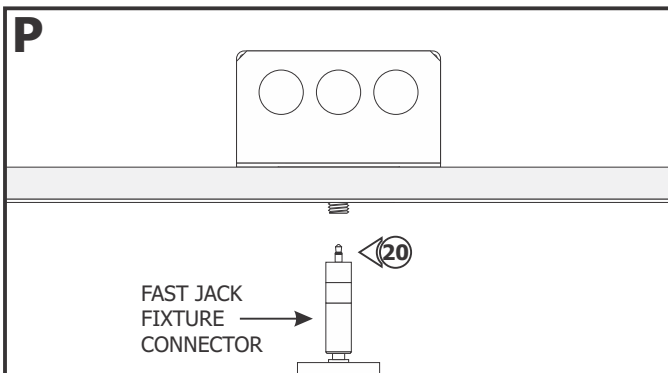
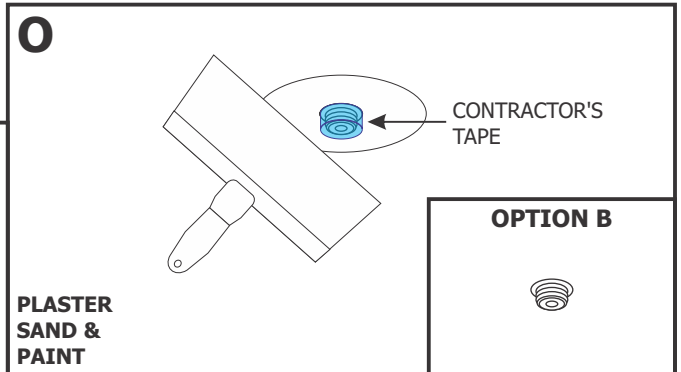

CAUTION: Risk of Fire: Do not load the port greater than included power supply rated wattage (**15W** or **60W**).

20: Use fingers to tighten the Fast Jack connector into the Fast Jack port.

General Wiring for Remote Power

