



1718 W. Fullerton Chicago, IL 60614
 Ph: 773.770.1195 • Fax: 773.935.5613
 www.PureEdgeLighting.com • info@PureEdgeLighting.com
 © 2016 PureEdge Lighting. All Rights Reserved.

Installation Instructions for Vanishing Point Tubo Small Down Light LED 24VDC

V_-HW24-TUBSD-_

IMPORTANT INFORMATION

- This instruction shows a typical installation.
- This product is ceiling mount.

SAVE THESE INSTRUCTIONS!

Section One: Install the Junction Box

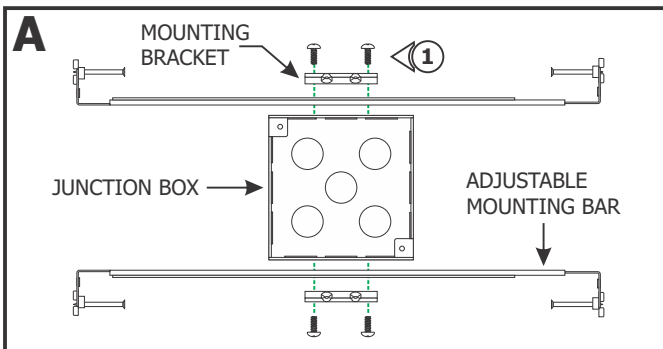

- 1:** Mount each adjustable mounting bar to one side of the junction box and secure them with the mounting brackets and two Phillips screws provided.

NOTE: Adjustable mounting bars mount to studs that are spaced 14.5" to 25" apart.

- 2:** Select the location between the two studs for the junction box to be mounted.
- 3:** Place the adjustable mounting bar tabs between the studs. Secure the adjustable bars to the studs with the #8 screws.
- 4:** Pinch anywhere on the inner edge of the mounting bars to lock in place.

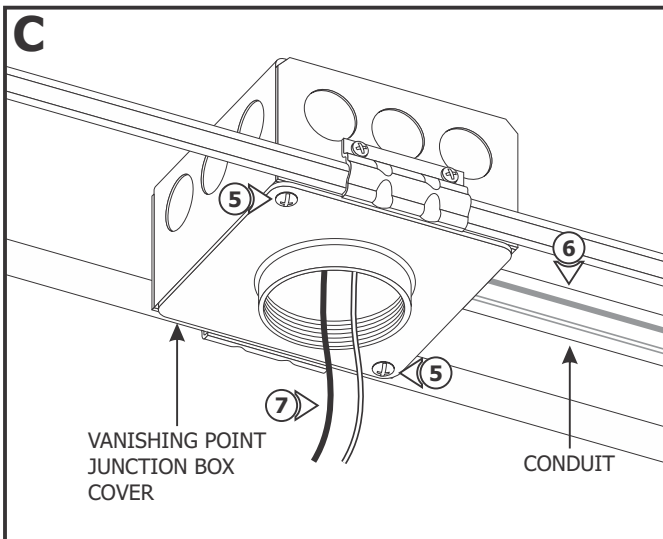
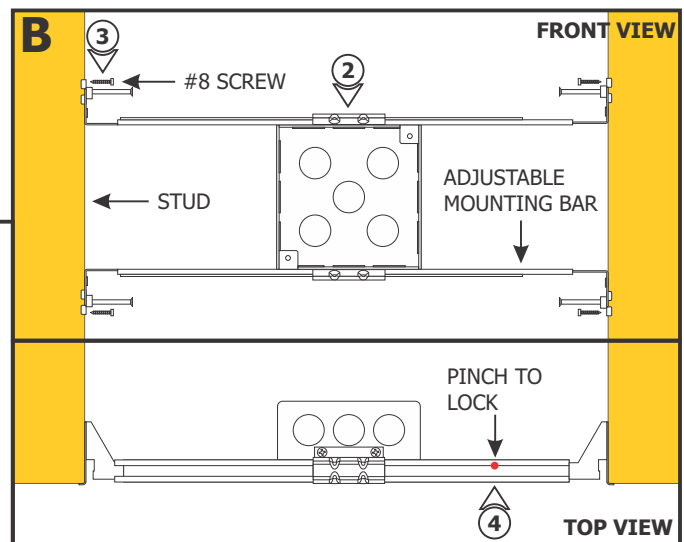

- 5:** Install the Vanishing Point junction box cover to the junction box using two #8-32 screws.
- 6:** Remove a knockout to install a conduit into the junction box. Install conduit(s) (if required by local electrical code).
- 7:** Run the line voltage wires to the junction box.
- 8:** If using remote power supply, then run the low-voltage 24V wires coming from the remote power supply to the junction box.

NOTE: Ensure remote power supply wires are present in the junction box. Refer to instructions provided with the power supply.

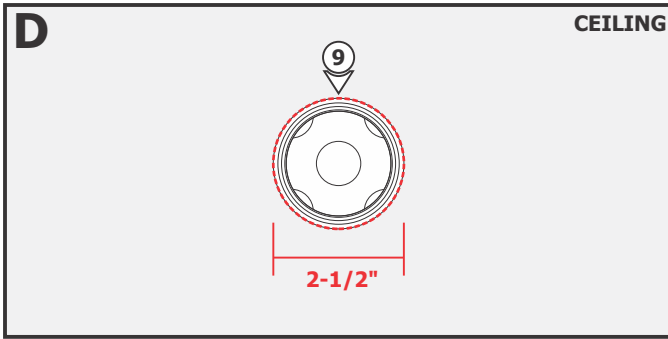

9: Use a 2-1/2" hole saw to cut out the drywall section where the junction box opening is located.

10: Install the drywall. If necessary, plaster and finish the drywall.

Section Two: Install the Fixture

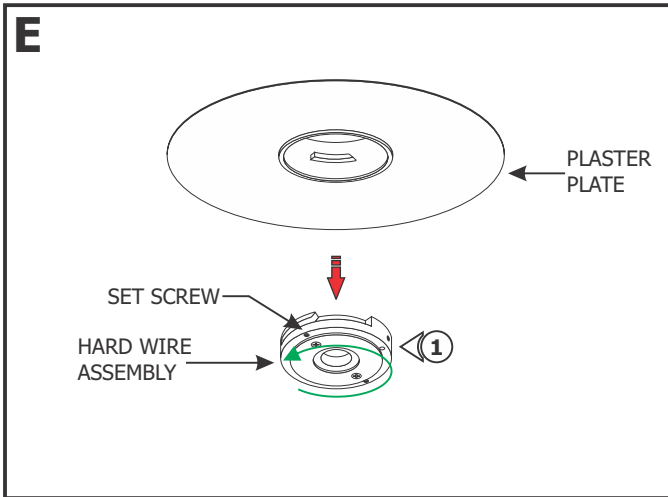

1: Loosen (**Do Not Remove**) the #4-40 set screws on the Hard Wire assembly using a 0.05" Allen wrench and rotate the Hard Wire assembly counter clockwise to remove from the Plaster Plate.

- 2:** Screw the plaster plate clockwise into the junction box cover, ensuring the plate is tight.
- 3:** If the drywall is 5/8" thick, tighten the bottom #4-40 set screw inside the plaster plate using a 0.05" Allen wrench.
- 4:** If the drywall is 3/4" and thicker, tighten the top #4-40 set screw inside the plaster plate using a 0.05" Allen wrench.

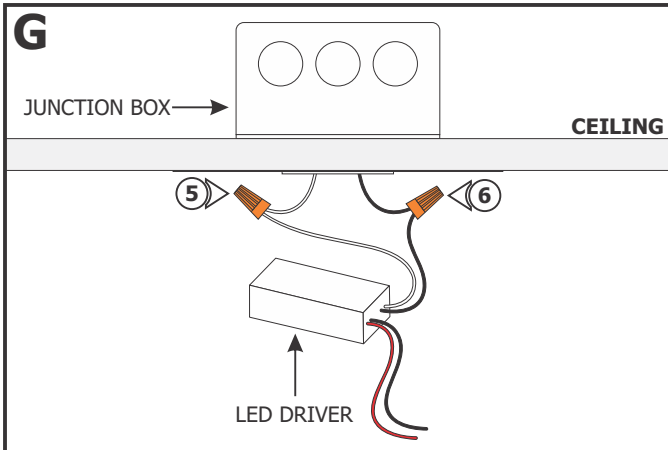
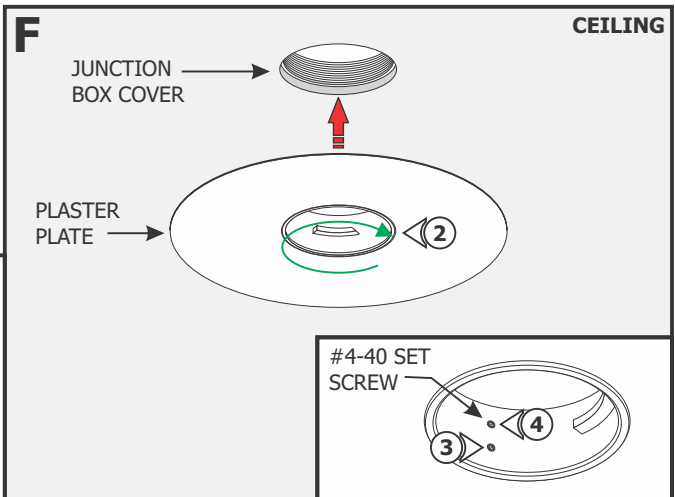

NOTE: Steps 5 through 7 are for the 24V power supply included inside the junction box. Omit these steps if using remote power supply.

NOTE: Make sure the junction box is grounded in accordance to local electrical codes.

5: Connect the white LED driver wire to the neutral power wire with a wire nut.

6: Connect the black LED driver wire to the hot power wire with a wire nut.

7: Place the LED driver and wire nut connections inside the junction box.

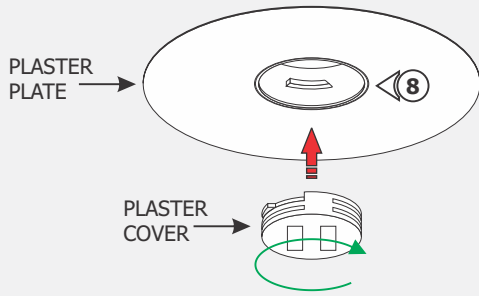
H**CEILING****8:** Rotate the plaster cover clockwise into the plaster plate.**9:** Plaster, sand and paint the surface.

NOTE: For areas with lots of vibration, it is suggested to use Durabond to avoid cracking of plaster.

NOTE: **Do Not use premixed joint compound "Soft Mud."**
No use compuesto para juntas premezclado "Soft Mud."

NOTE: Recommended plaster method: 1st Coat - Durabond 45 with 8" Blade, 2nd Coat - Easy Sand 45 with 10" Blade, 3rd Coat with 12" Blade

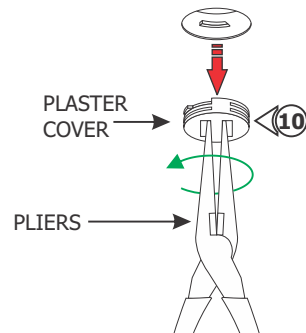
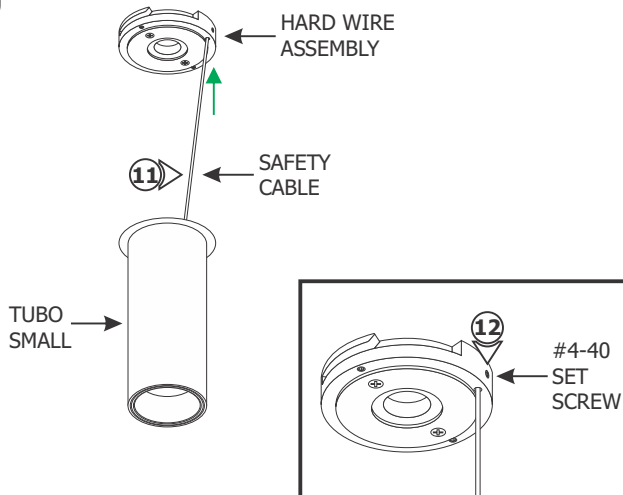
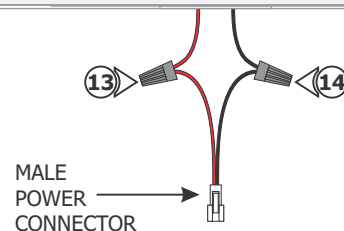
I**10:** Use pliers to rotate the plaster cover counter clockwise and remove it. Clean the hole.**J****11:** Insert the safety cable on the Tubo Small track head into the hole on the Hard Wire assembly.**12:** Tighten the #4-40 set screw on the side of the assembly using a 0.05" Allen wrench.**13:** Connect the red wire of the male power connector to the +24VDC power supply wire using a wire nut.**14:** Connect the black wire of the male power connector to the -24VDC power supply wire using a wire nut.**K**

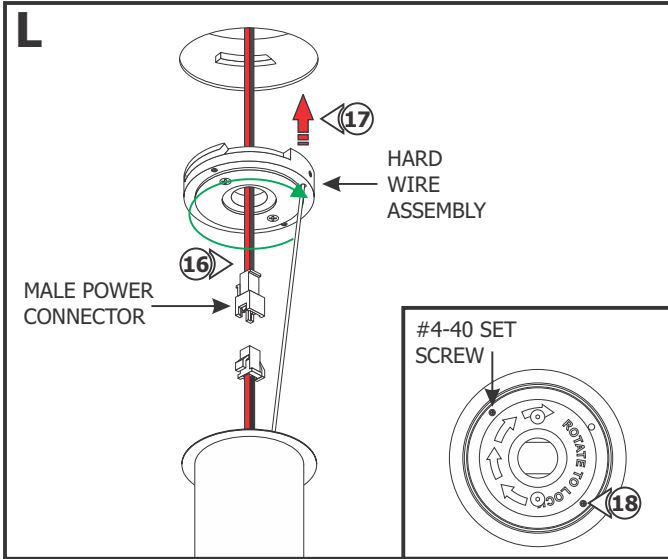

15: Place all wire nut connections inside the junction box.

16: Feed the male power connector through the Hard Wire assembly.

17: Insert the Hard Wire assembly into the opening and rotate clockwise to lock in place.

18: Tighten the #4-40 set screws using a 0.05" Allen wrench to secure in place.

19: Push to snap the female connector of the Tubo Small track head to the male power connector.

20: Place the power connectors inside the junction box.

NOTE: Test the fixture.

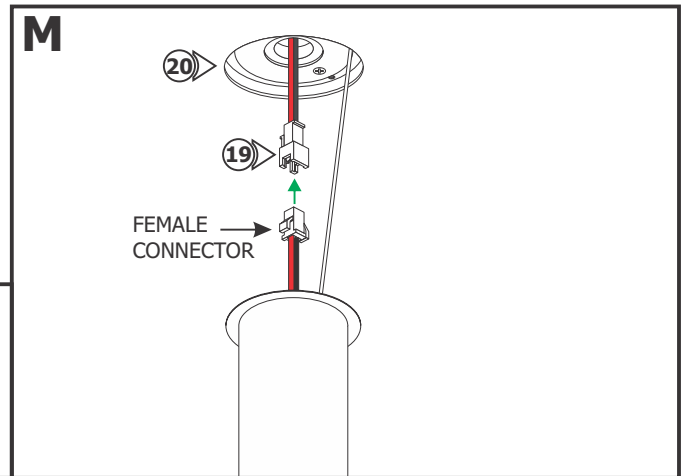

21: Place the Tubo Small track head over the Hard Wire assembly. The magnets on the back will keep the track head in place.

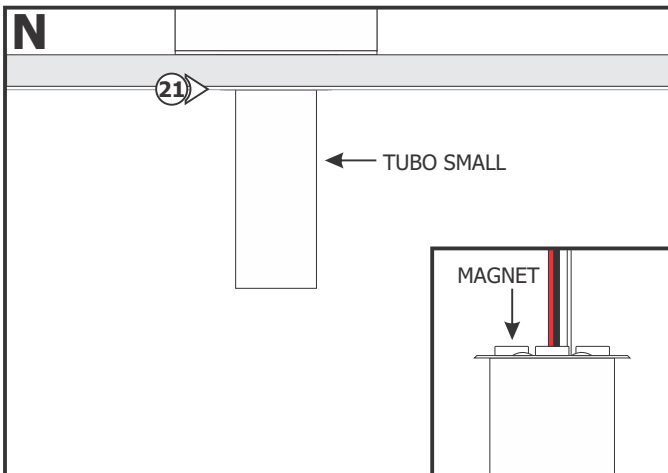

Section Three: Replace the Reflector

O

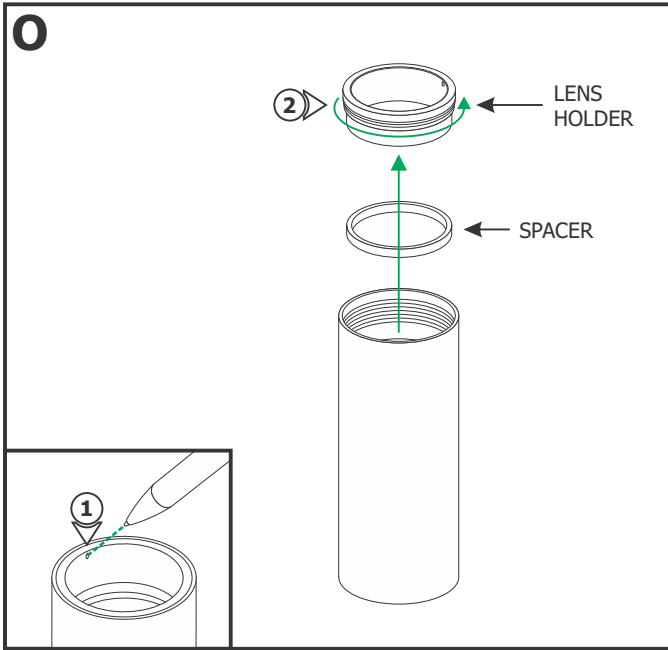

1: Use a pen or small Allen wrench to loosen the lens holder.

2: Unscrew the lens holder counter-clockwise and remove the lens holder and spacer from the fixture.

P

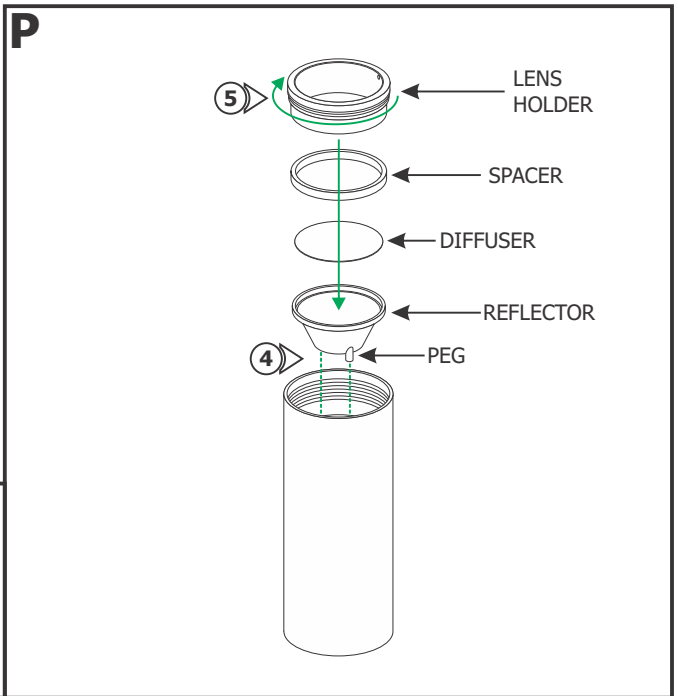

3: Remove the diffuser and the reflector.

4: Replace the reflector by aligning the pegs with the LED module holes.

5: Replace the diffuser and spacer over the reflector and screw the lens holder back clockwise to secure in place.

General Wiring for Remote Power

