

- ① Fissare la staffa a parete o al soffitto. (utilizzare tasselli appropriati in base al tipo di muro)

Fix the bracket on the wall or the ceiling. (use appropriate anchors depending on the type of wall)

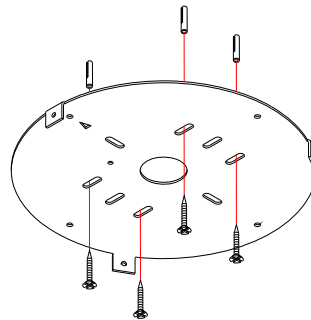

CE

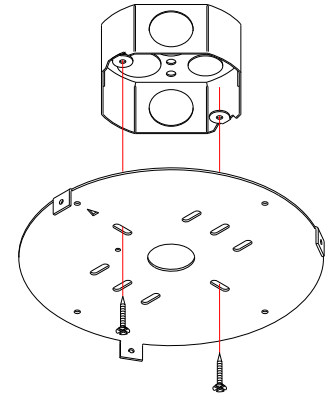

USA

- ! Tenere come riferimento lo schema affianco per il posizionamento della staffa. Ogni staffa è distinta da una freccia (evidenziata in rosso nello schema), il posizionamento del vetro diffusore è dipendente dall'orientamento della freccia.

Keep the side diagram as a reference for positioning the bracket. Each bracket is distinguished by an arrow (highlighted in red in the diagram), the positioning of the diffuser glass depends on the orientation of the arrow.

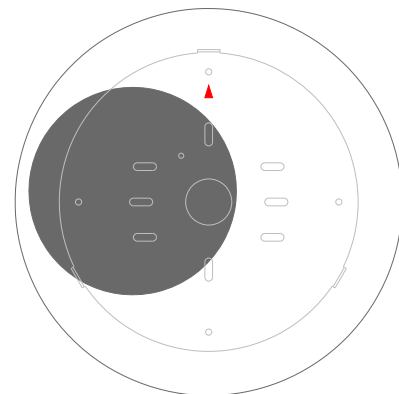

- ② Eseguire il cablaggio come illustrato nello schema. *Carry out the wirings as shown in the diagram.*

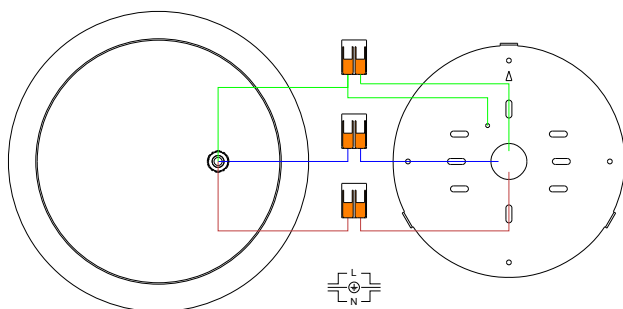

CE

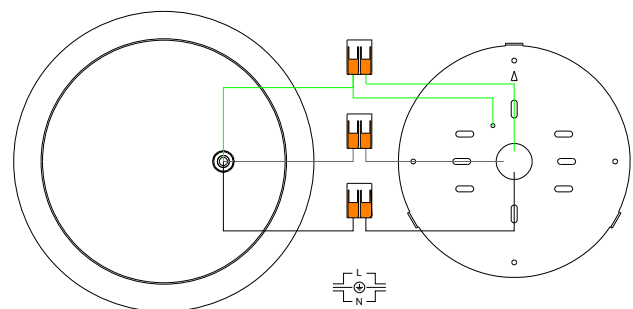

USA

- ③ Fissare il rosone alla staffa utilizzando le viti fornite.
Inserire la lampadina.
*Fix the canopy to the bracket using the screws provided.
Insert the bulb.*

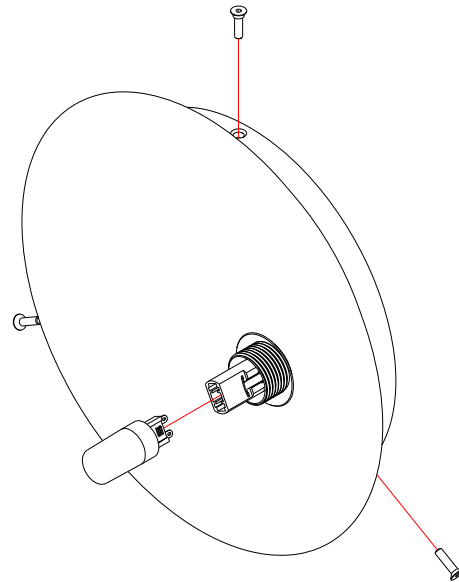

- ④ Inserire il diffusore in vetro sul suo supporto.
Assicurarsi che il vetro sia ben saldo.
*Insert the glass diffuser on its support.
Make sure the glass is secure.*

