

## COMMERCIAL DOWNLIGHT INSTALLATION GUIDE – WARNING

- WARNING** – Read all product labels and instructions before installing fixture.
- WARNING** – Risk of fire or electric shock. LED Retrofit Kit installation requires knowledge of luminaires electrical systems. Installation should be performed only by a qualified electrician in accordance with the National Electrical Code and relevant local code.
- WARNING** – Risk of fire or electric shock. Install this kit only in the luminaires that have the construction features and dimensions shown in the photographs and/or drawings.
- WARNING** – To prevent wiring damage or abrasion, do not expose wiring to edges of sheet metal or other sharp objects.
- WARNING** – Do not make or alter any open holes in an enclosure of wiring or electrical components during kit installation.
- WARNING** – The recessed luminaire is intended for mounting only in a covered ceiling where only the led side of the luminaire will be exposed to damp or dry locations.
- WARNING** – INSTALLATION SHOULD ONLY BE PERFORMED AFTER POWER TO THE FIXTURE HAS BEEN DISCONNECTED.

## COMMERCIAL DOWNLIGHT INSTALLATION

1. Make sure the POWER IS TURNED OFF at the source to the recessed housing in which you are installing the product.
2. Remove the existing lamps and trim (fig. 1).
3. Open the J-box and cut away all wires connected to the ballast (fig. 2).
4. Set the LED driver box beside the housing frame. Insert the open connection end into the existing J-box and wire to the power source (black to hot, white to neutral, green to ground) (fig. 3). For dimming circuits, connect grey to grey and purple to purple. If no 0-10V dimming circuit is present, cap off the grey and purple wires. Reattach J-box faceplate.
5. To make installing the downlight easier, attach the carabiner safety clip to a secure location above housing in the ceiling. Before connecting the power conduit quick connector to the driver, push the downlight up into the housing to determine if retaining clips are necessary. For 6 and 8" housing you might need to use the slide-on clips based on downlight and housing compatibility (fig. 4).
6. For loose fitting housing use the three slide-on retaining clips provided. Slide each clip onto the existing housing so the clip teeth are facing downwards (fig. 5).
7. Connect the driver and the downlight using the quick connector. Insert the flex conduit inside the open knock-out of the driver box to complete the connection (fig. 6 & 7).
8. Push the trim up into the housing frame until flush with the ceiling (fig.8A). For 9.5" downlight push up the spring-action clips and insert the downlight in the housing (fig.8B), then release the spring. Make sure the downlight is securely installed (fig.9).
9. Restore the power at the source and the installation is completed.

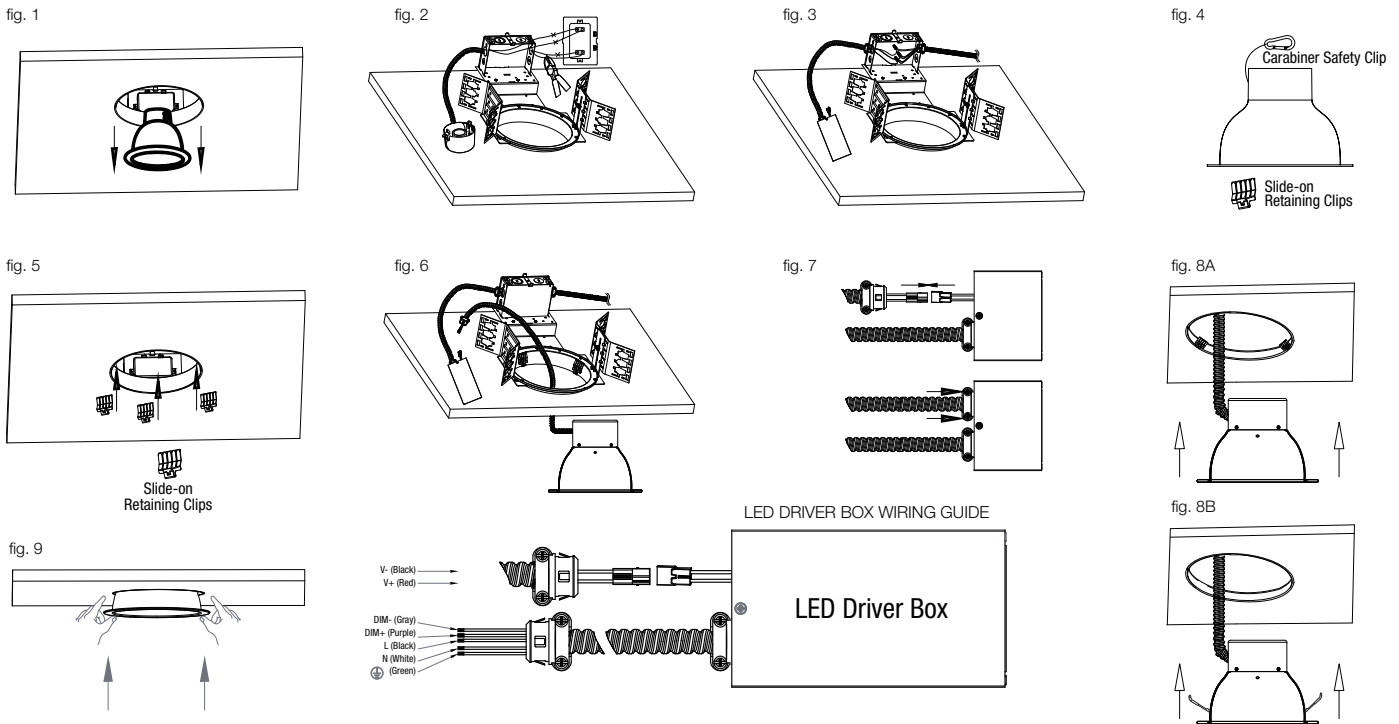

## COMMERCIAL DOWNLIGHT HOUSING COMPATIBILITY



Model No.:	A	B	C
18CDL6DIM/xxx/277V	6-3/16"	7-13/16"	5-11/16"
24CDL8DIM/xxx/277V	7-3/4"	9-1/4"	6-5/16"
30CDL9.5DIM/xxx/277V	9-3/8"	10-3/4"	7-7/8"

18CDL6DIM/xxx/277V is compatible with most standard housing aperture ranging from 6-5/16"-6-7/8"  
 Juno: CVT6-118T, CVT6-126/32T, CV6-126Q, CH6-213Q, CH6-218Q, CH6-226Q  
 Econolight: E-A6NN27-UT, E-A6HN36-UT, E-A6HN52-UT  
 Lithonia: LP6FN, LF6N

24CDL8DIM/xxx/277V is compatible with most standard housing with aperture ranging from 7-13/16"-8-3/8"  
 Juno: CVT8-126/32/42T, CH8-213Q, CH8-218Q, CH8-226Q  
 Lithonia: LP8FN

30CDL9.5DIM/xxx/277V is compatible with most standard housing with aperture ranging from 9-1/2"-10-3/16"  
 Juno: M10-ED-100E, M10-ED-150E120, 10-ED-150E277  
 Cooper: C9142/57/70, C9257