

MONTAJE - MONTATGE - GEBRAUCHSANWEISUNG - ASSEMBLING - MONTAGE

1 FIJAR PLACA METÁLICA A LA PATA.
FIX METALLIC PLATE TO THE LEG.

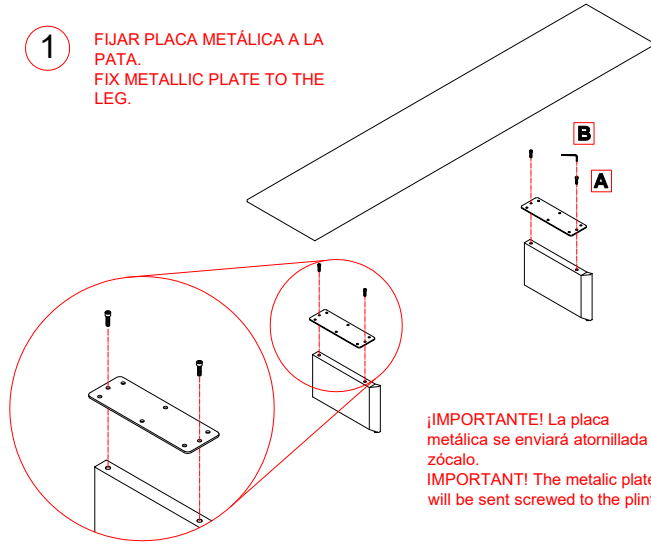

2 FIJAR PATAS AL ZÓCALO A TRAVÉS DE LA PLACA METÁLICA.
FIX WOODEN LEG TO PLINTH THROUGH THE METAL PLATE.

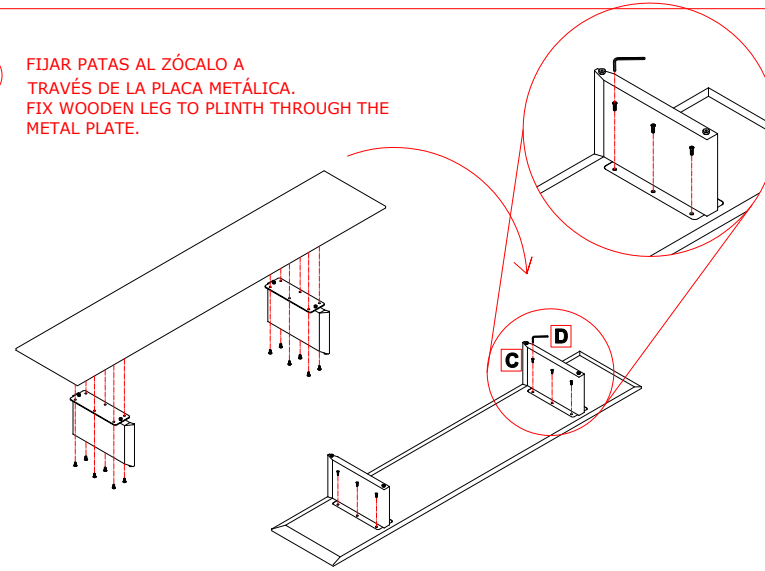

3 FIJAR LA PLETINA AL ZÓCALO.
FIX THE PLATE TO THE PLINTH

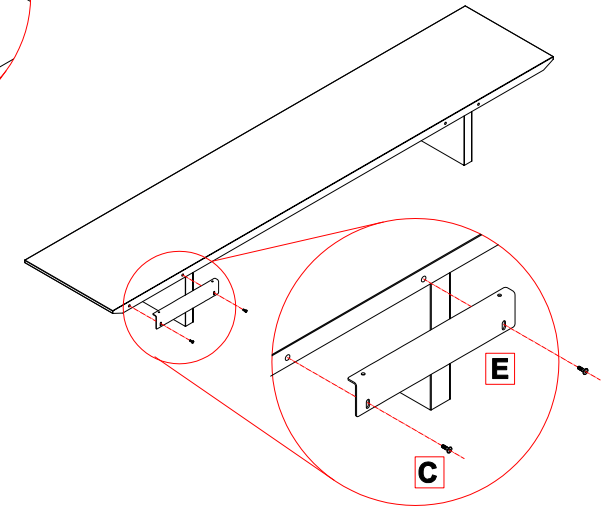

4 POSICIONAR EN SITIO FINAL Y REGULAR.
POSITION IN FINAL PLACE AND ADJUST.

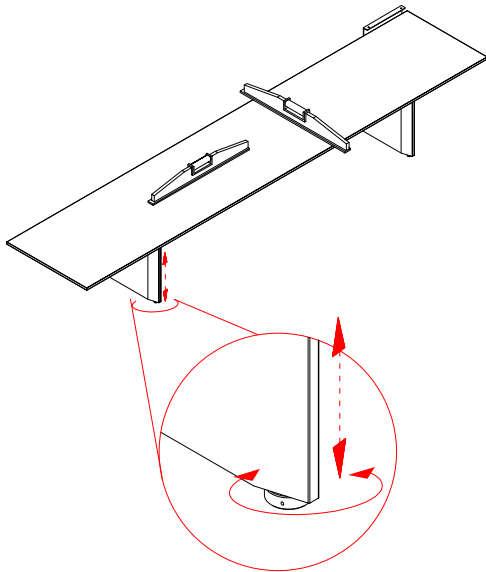

5 LIMPIAR SUPERFICIE DEL ZÓCALO Y DE LOS ANTIDESLIZANTES (PARTE DELANTERA) ANTES DE APOYAR EL MUEBLE SOBRE EL ZÓCALO
CLEAN SURFACE OF THE PLINTH AND OF THE TWO ANTI-SKID (FRONT SIDE) BEFORE PLACING THE MODULE ON THE PLINTH

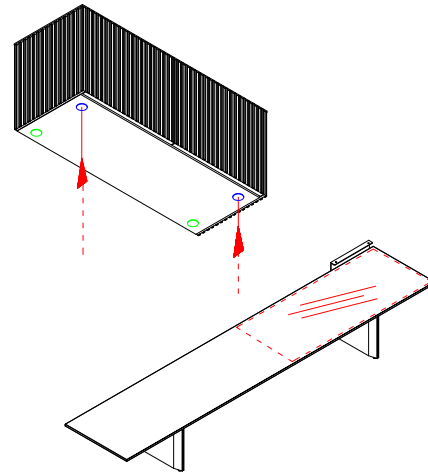

6 COLOCAR MÓDULO SOBRE EL ZÓCALO.
PLACE MODULE ON THE PLINTH.

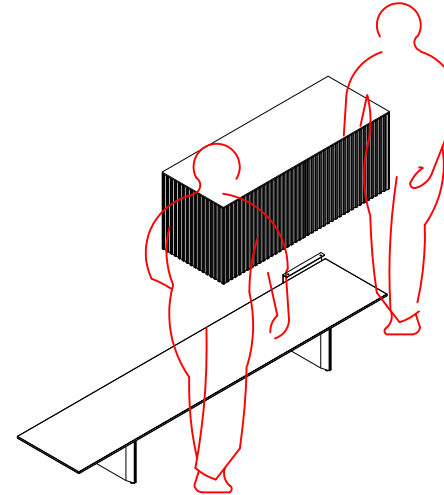

6.1 APOYAR EL MÓDULO CON INCLINACIÓN PARA DESLIZAR Y ENCAJARLO CON EL AGARRE.
SUPPORT THE MODULE WITH INCLINATION TO SLIDE AND FIX IT WITH THE GRIP.

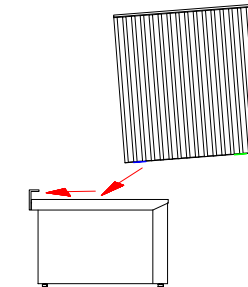

6.2 BAJAR LA PARTE DELANTERA DEL MÓDULO.
LOWER THE FRONT OF THE MODULE.

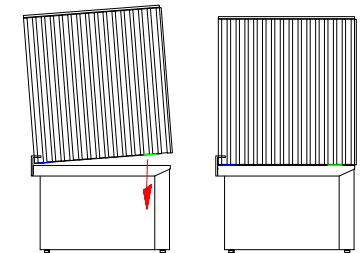

HERRAJE - FERRATJE - FITTINGS - EISENBSCHLAG - QUINCALLERIE - FERRAMENTA - HERRAJE - FERRATJE - FITTINGS - EISENBSCHLAG - QUINCALLERIE - FERRAMENTA - HERRAJE - FERRATJE - FITTINGS - EISENBSCHLAG



1 FIJAR PLACA METÁLICA A LA PATA.
FIX METALLIC PLATE TO THE LEG.

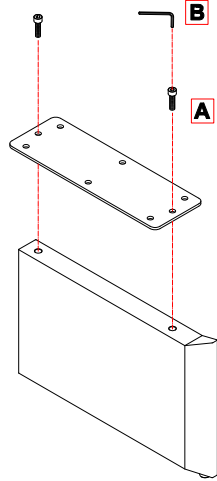

¡IMPORTANTE! La placa metálica se enviará atornillada a la tapa.
IMPORTANT! The metallic plate will be sent screwed to the top.

2

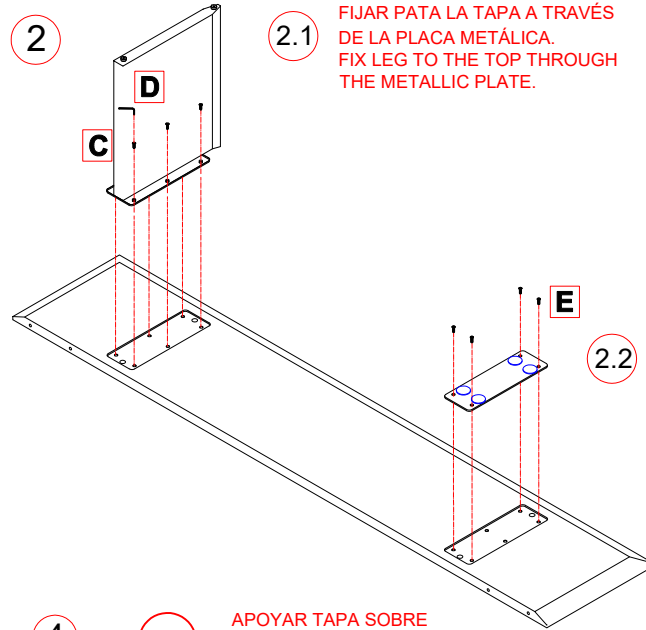

2.1 FIJAR PATA LA TAPA A TRAVÉS DE LA PLACA METÁLICA.
FIX LEG TO THE TOP THROUGH THE METALLIC PLATE.

2.2 FIJAR LA PLACA EMBELLECEDORA A LA TAPA.
FIX THE TRIM PLATE TO THE TOP.

3 INTRODUCIR REGULABLES A PRESIÓN.
INSERT ADJUSTABLE BY PRESSING

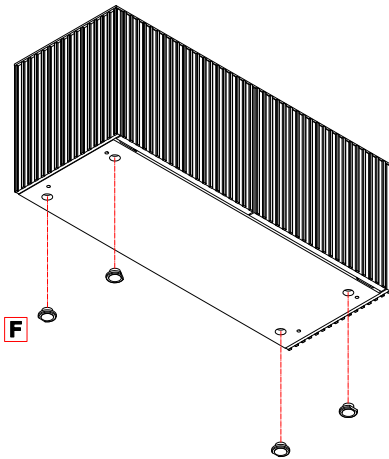

4

APOYAR TAPA SOBRE MÓDULO
SUPPORT TOP ON MODULE.

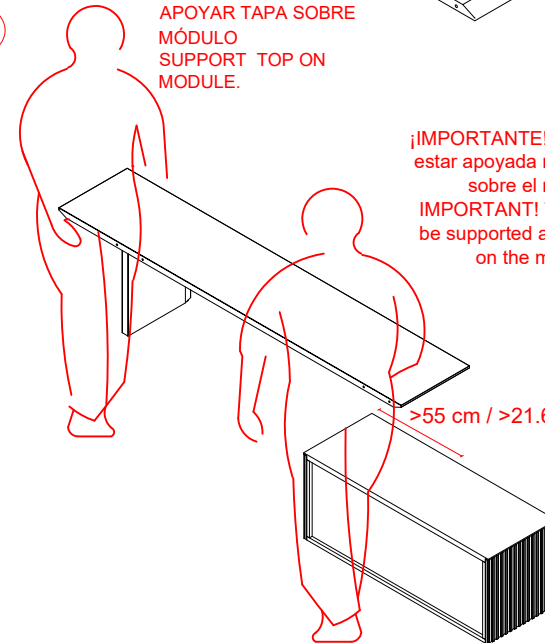

¡IMPORTANTE! La tapa debe estar apoyada mínimo 50 cm sobre el módulo.
IMPORTANT! The top must be supported at least 50 cm on the module.

HERRAJE - FERRATJE - FITTINGS - EISENBSCHLAG - QUINCALLERIE - FERRAMENTA - HERRAJE - FERRATJE - FITTINGS - EISENBSCHLAG - QUINCALLERIE - FERRAMENTA - HERRAJE - FERRATJE - FITTINGS - EISENBSCHLAG

A



B



C



D



E



F



5 FIJAR MÓDULO AL ZÓCALO.
FIX MODULE TO THE PLINTH.

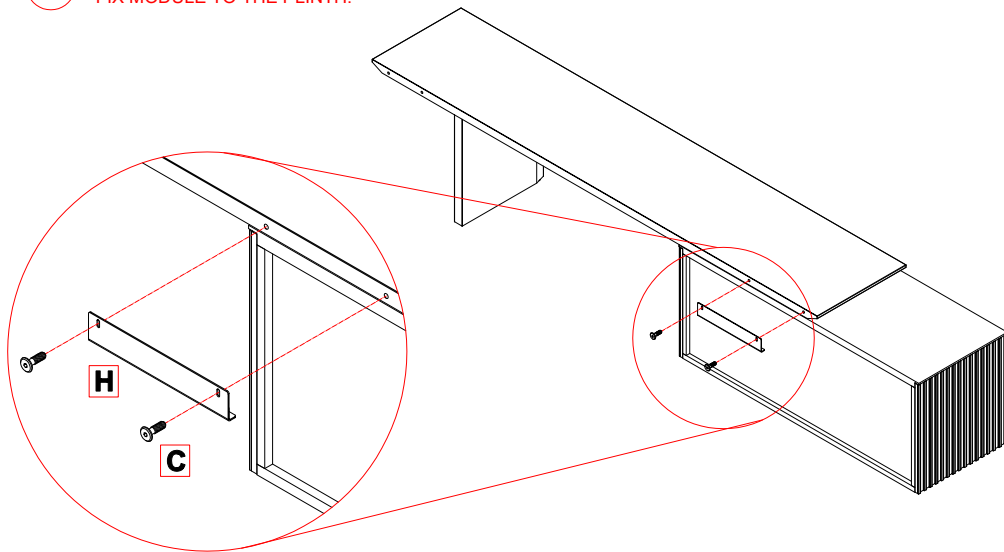

6 REGULAR MÓDULO Y TAPA.
ADJUST MODULE AND TOP.

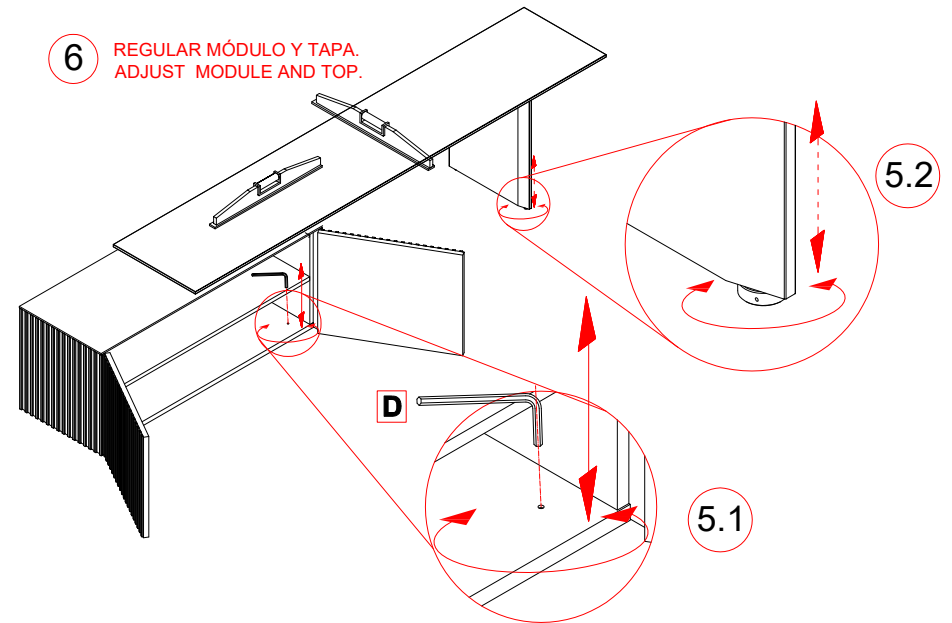

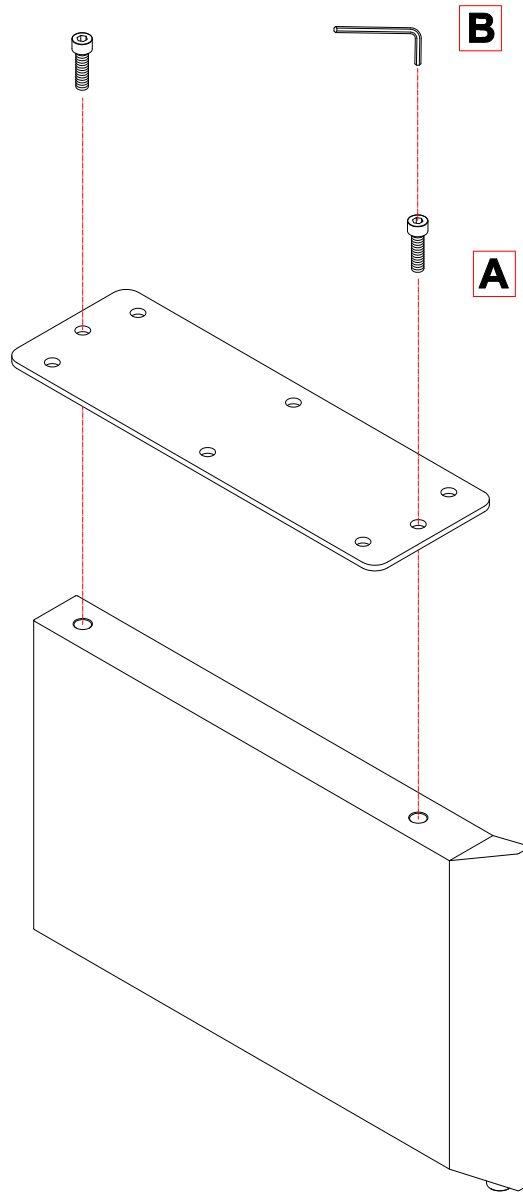

HERRAJE - FERRATJE - FITTINGS - EISENBESCHLAG - QUINCALLERIE - FERRAMENTA - HERRAJE - FERRATJE - FITTINGS - EISENBESCHLAG - QUINCALLERIE - FERRAMENTA - HERRAJE - FERRATJE - FITTINGS - EISENBESCHLAG

A



98917
DIN912 - M8X35

2 uds

B



N° 4 98595

1 uds

C



98900
M8X20

6 uds

D



N° 6 98599

1 uds