

INSTALLATION INSTRUCTION

Accent Light

LC-253205

WAC

SAFETY INSTRUCTION

IMPORTANT: NEVER attempt any work without shutting off the electricity.

- Read all instructions before installing.
- System is intended for installation by a qualified electrician in accordance with the National Electrical Code and local regulations.
- Place the wall switch in the "OFF" position.
- Go to the main fuse box, or circuit breaker. Unscrew the fuse(s) or switch "OFF" the circuit breaker switch(es) that control the power to the space that you are working on.

WARNING: Risk of electric shock. Install all luminaires 10 feet (3.05 m) or more from a pool, spa, or fountain.

CAUTION:

All parts must be used as indicated in these instructions. Do not substitute any parts, leave parts out, or use any parts that are worn out or broken. Failure to follow this instruction could invalidate the UL listing of this fixture.

AVERTISSEMENT

IMPORTANT : COUPEZ L'ÉLECTRICITÉ AVANT TOUTE MANIPULATION.

- Lisez toutes les instructions avant d'installer.
- Système est destiné à être installé par un électricien qualifié en conformité avec le code national de l'électricité et les règlements locaux.
- Placez l'interrupteur mural en position d'arrêt (« OFF »).
- Accédez au panneau central de disjoncteurs ou de fusibles de votre demeure et placez l'interrupteur principal en position d'arrêt (« OFF »).

MISE EN GARDE

Toutes les pièces doivent être utilisées tel qu'il est indiqué dans ces instructions. Ne remplacez pas les pièces, n'en laissez pas de côté et ne les utilisez pas si elles sont usées ou brisées. Le non-respect de ces instructions peut annuler l'homologation UL du luminaire.

**Note: Transformer is required to power the fixture. (sold separately)*

THIS INSTRUCTIONS APPLY TO THE MODELS BELOW:

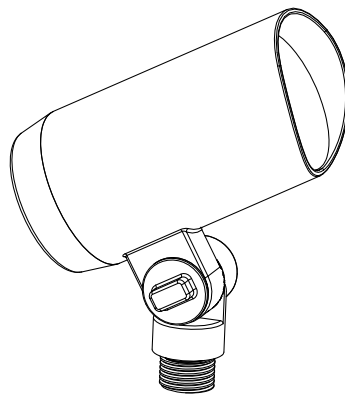

LC-253205

Mounting Accessories (included in box)

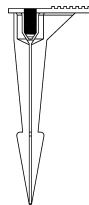

Mounting Stake
Qty: 1 pcs



Outdoor Rated Wire Nut
Qty: 2 pcs

wacighting.com

Phone (800) 526.2588

Fax (800) 526.2585

Headquarters, East Manufacturing Facility

44 Harbor Park Drive

Port Washington, NY 11050

South East Manufacturing Facility

1600 Distribution Ct

Lithia Springs, GA 30122

Central Manufacturing Facility

1700 South J Elmer Freeway, Ste 100

Cedar Hill, TX 75104

West Manufacturing Facility

1750 S Archibald Ave

Ontario, CA 91761

INSTALLATION INSTRUCTION

Accent Light

LC-253205

WAC

Step 1: Assemble the fixture

1. Screw the fixture onto the stake provided, leading the wire from the fixture through the wire slot in the stake as shown in fig.1
2. If desired, bury your wire by digging a small trench. When finish burying the wires, close the trench.

Step 2: Install the fixture

1. Gently drive the stake into the ground via the footplate at your chosen location having the fixture to the desired position as shown in fig.2 and fig.3.
2. In the case of hard soil, dig a hole and place the stake in so that the bottom of the stake flange is flush with the ground. Fill the rest of the hole with the removed soil and pack it tight to secure the stake.

Step 3: Wiring the Fixture

**Note: Transformer is required to power the fixture. (sold separately)*

1. Cut the power supply wire from the transformer at the location of the fixture as shown in fig.4.
2. Separate the power supply wire into two individual wires by lightly pulling on each side so that a couple inches is separated.
3. Strip off ½ inch of the insulating material from each wire and connect one to each of the wires from the fixture using the outdoor rated wire nuts provided.

Step 4: Select color temperature

1. Open the back cover of the fixture, select your desire color temperature via the toggle switch inside. Then close back cover as shown in fig.5.
2. Turn the main power supply back on.

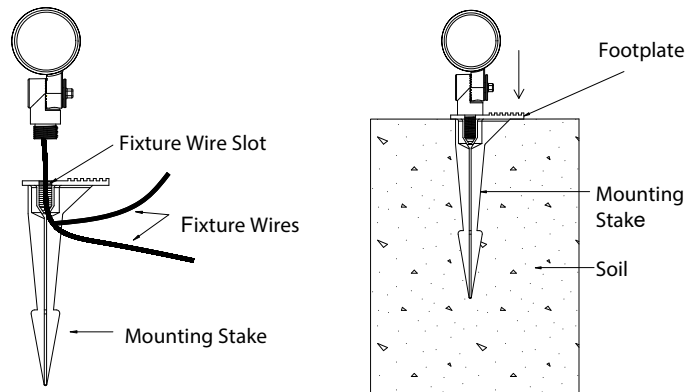

Fig.1

Fig.2

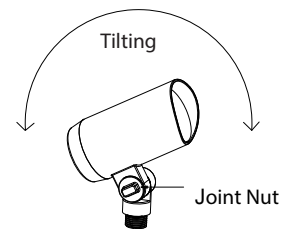

Fig.3

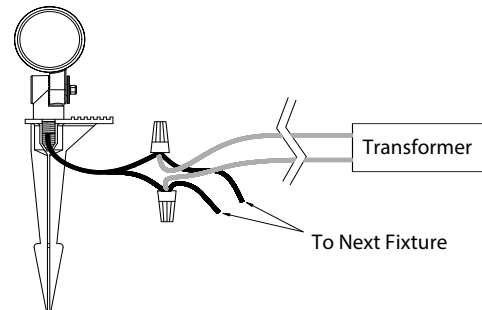

Fig.4

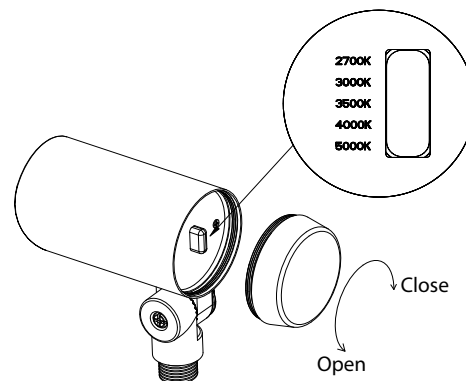

Fig.5

wacighting.com

Phone (800) 526.2588

Fax (800) 526.2585

Headquarters, East Manufacturing Facility

44 Harbor Park Drive

Port Washington, NY 11050

South East Manufacturing Facility

1600 Distribution Ct

Lithia Springs, GA 30122

Central Manufacturing Facility

1700 South J Elmer Freeway, Ste 100

Cedar Hill, TX 75104

West Manufacturing Facility

1750 S Archibald Ave

Ontario, CA 91761