

Artemide[®]

ARCHITECTURAL

LA LINEA - WALL /CEILING

design
BIG

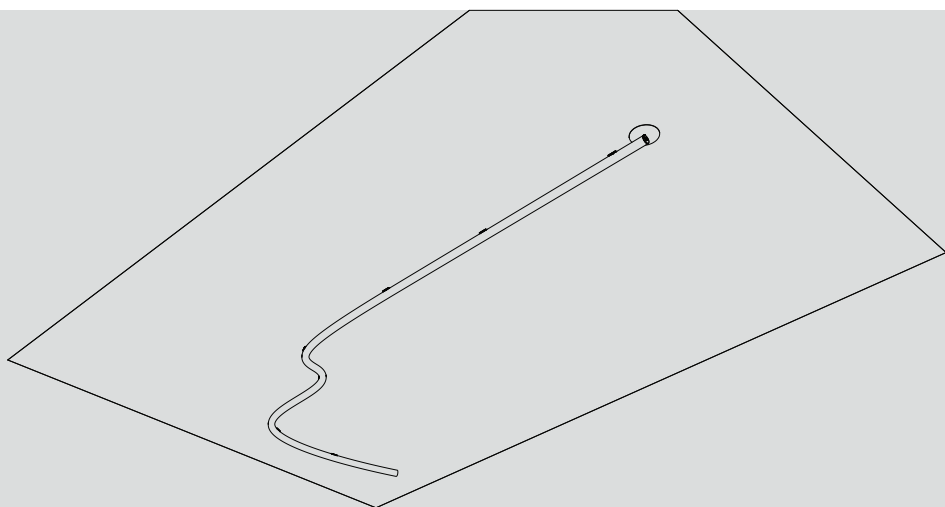



Warning: Read and understand these instructions before installing fixture. This fixture is intended for installation in accordance with National Electric Code and local regulation: To assure full compliance with local codes and regulations, check with your local electrical inspector before installation. This equipment is guaranteed only when used as indicated in these instructions; therefore, they should be kept for future reference. To prevent electrical shock, turn off power supply before carrying out any connection or maintenance operations.

Attention: Lisez et comprenez bien ces instructions avant d'installer le luminaire. Ce luminaire est conçu pour être installé conformément au code national de l'électricité et aux réglementations locales: pour garantir la conformité totale aux codes et réglementations locaux, vérifiez auprès de votre inspecteur en électricité local avant l'installation. Cet équipement n'est garanti que s'il est utilisé comme indiqué dans ces instructions; par conséquent, elles doivent être conservées pour référence future. Pour éviter les chocs électriques, couper l'alimentation avant de procéder à des opérations de connexion ou de maintenance.

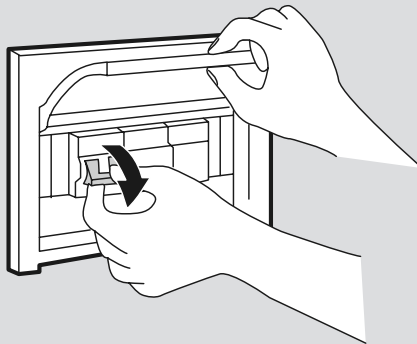

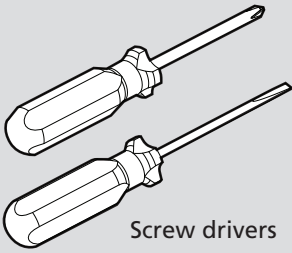
i**REQUIRED HARDWARE
QUINCAILLERIE REQUISE**

Screw drivers

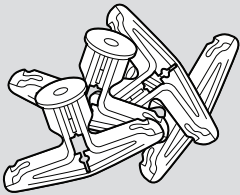
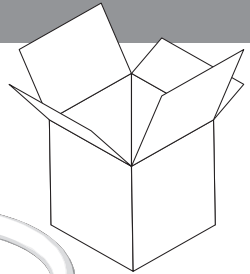
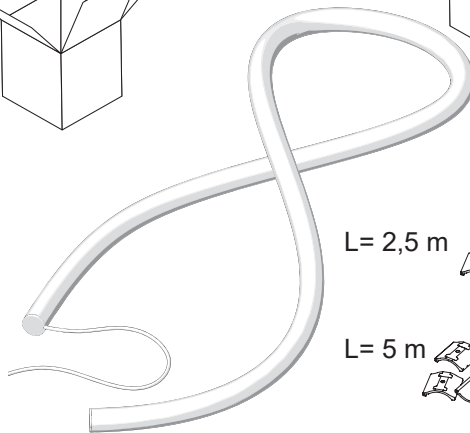
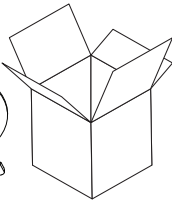
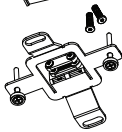
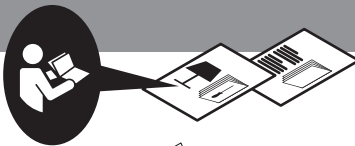
**Linea TD4601010 2.5m**x5 #8 screws for wall mounting
x5 Vis pour montage mural #8**Linea TD4600010 5m**x10 #8 screws for wall mounting
x10 Vis pour montage mural #8wall anchors suitable for screw size
encrages appropriés à la taille de vis

L= 2,5 m



L= 5 m



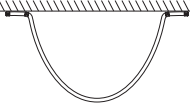
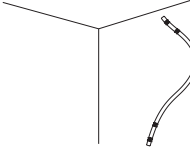
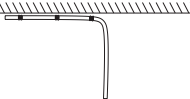
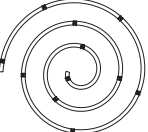
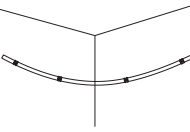
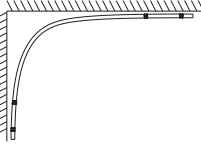

WALL CEILING FLOOR

	✓	✓	—
	✗	✓	—
	✓	—	—
	✗	✗	—
	✓	✓	—
	✓	—	—
	✓	✓	—

i

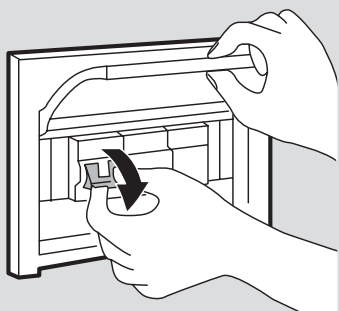
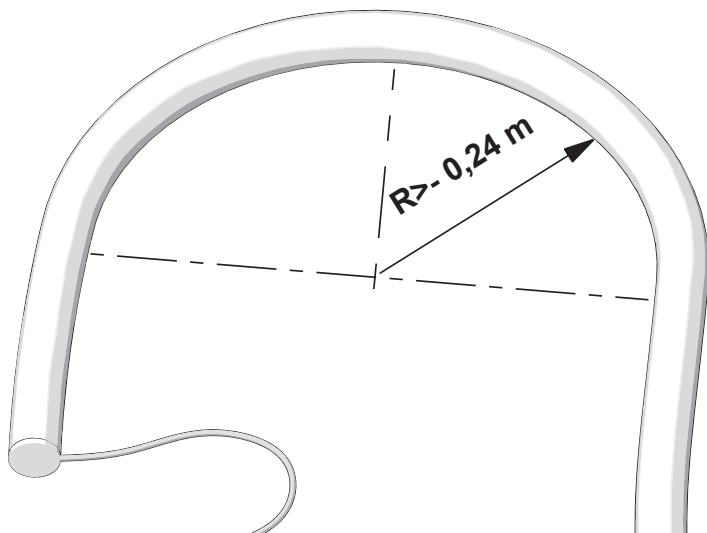

1

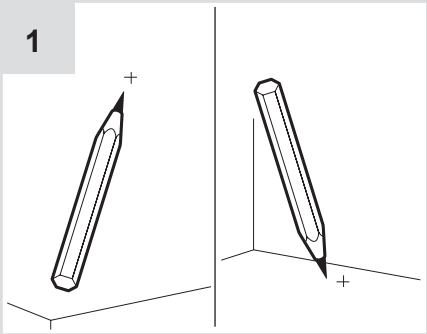

2

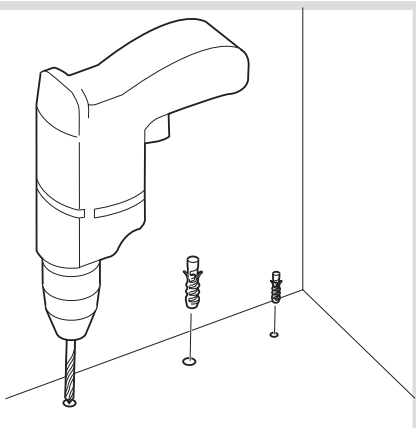
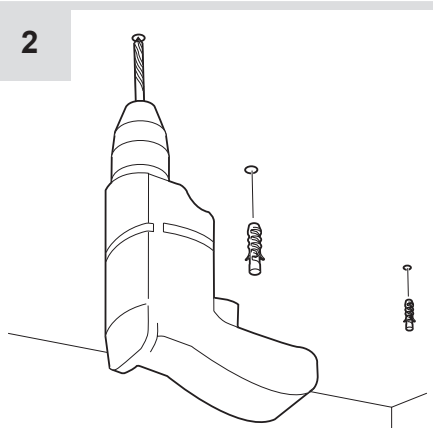

1

- En:** - Prepare holes for luminaire ceiling brackets.
 - Use appropriate anchors and screws (not included)
 - Add stopper under bracket before installing.

- Fr:** - Préparer les trous pour les supports de plafond du luminaire
 - Utilisez des ancrages et des vis appropriés (non inclus)
 - Ajouter la languette sous le support avant l'installation.

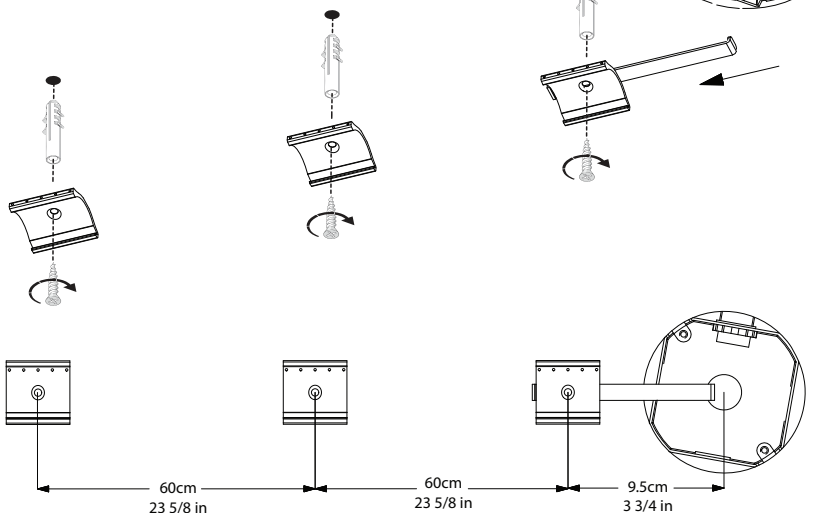
**2**

- En:** Insert tie wraps in holders
Fr: Insérer des serre-câbles dans les supports

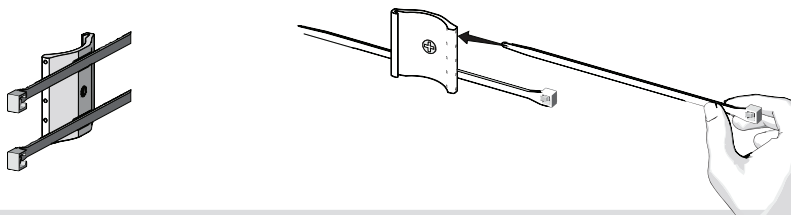
**3**

- En:** Install luminaire on brackets,
 electrical wire should be centered in junction box.
Fr: Installez le luminaire sur les supports,
 le fil électrique doit être centré dans la boîte de
 jonction

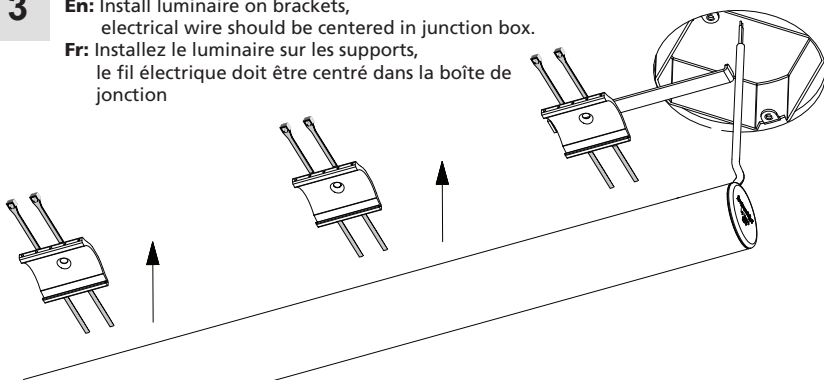

- 4** **En:** Tie loosely the luminaire on the brackets. Skip to tie the bracket close to the J-box for now.
Fr: Attachez sans serrer le luminaire sur les supports. Délaissez l'attache du support près de la boîte de jonction pour l'instant.

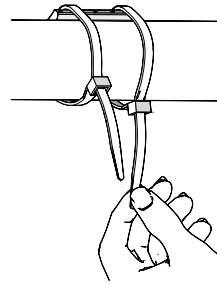
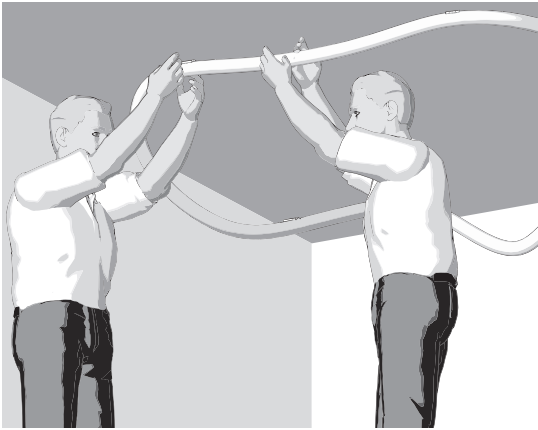

- 5** **En:** Insert bracket with strain relief in luminaire wire.
Fr: Insérez le support avec serre-câble dans le fil du luminaire.

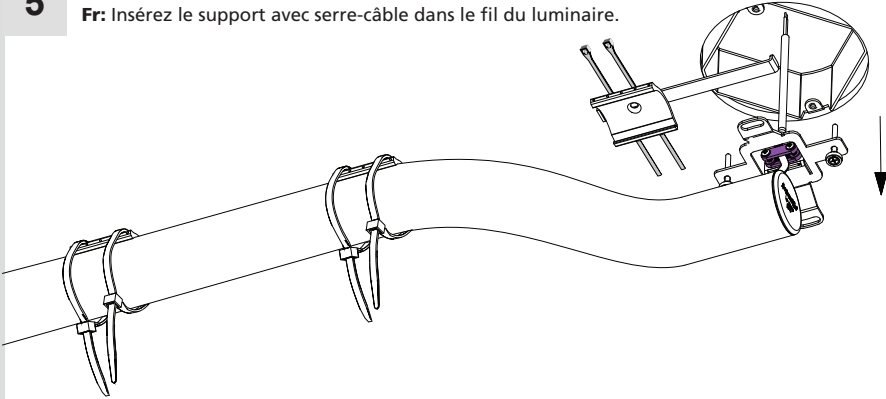

- 6** **En:** Screw strain relief on the wire to secure.
- with the help of the spacer tighten the strain relief at the appropriate place along the wire.
Fr: Visser le serre-câble sur le câble pour le fixer.
- à l'aide de l'entretoise, serrer le serre-câble à l'endroit approprié le long du fil.

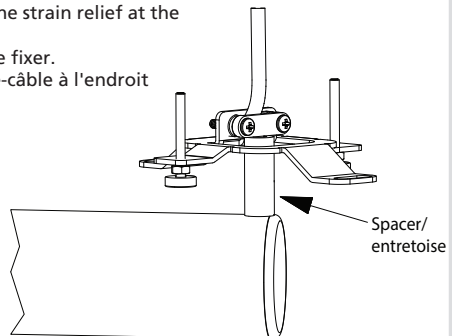

7 En: Make appropriate electrical connections
Fr: Réaliser les branchements électriques appropriés

Use only with class 2 power unit
Utiliser exclusivement avec class 2
alimentation
Utilícese únicamente con unidad
de alimentación de clase 2

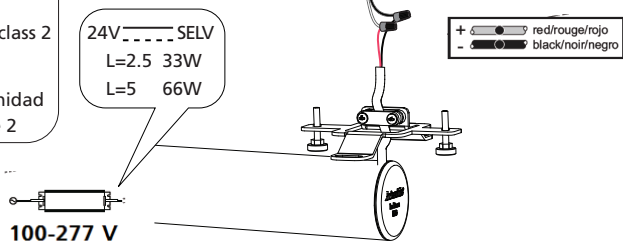

8 En: Screw in place junction box bracket with provided 8-32 screw
- Make sure luminaire is parallel to the ceiling
(if too low, unscrew bracket and readjust strain relief)
- When the position is good tighten all tie wraps
Fr: Vissez le support de la boîte de jonction avec les vis 8-32 fournies
- Assurez-vous que le luminaire est parallèle au plafond
(si trop bas, dévissez le support et réajustez le serre-câble)
- Quand la position est bonne serrer tous les attaches.

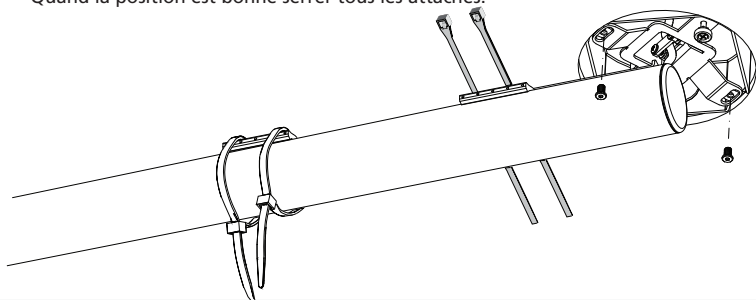

9 En: Secure the luminaire with pins and cut all tie wraps and remove them.
Fr: Fixez le luminaire avec des épingles et coupez toutes les attaches et retirez-les.

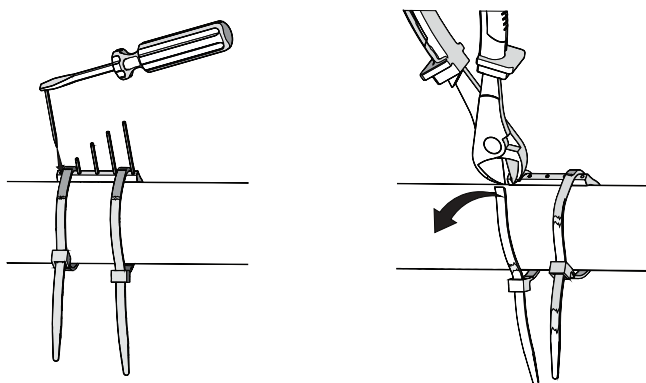

- 10** **En:** Slide the cover plate along the stopper to conceal junction box.
Fr: Faites glisser la plaque de recouvrement le long de la languette pour dissimuler la boîte de jonction.

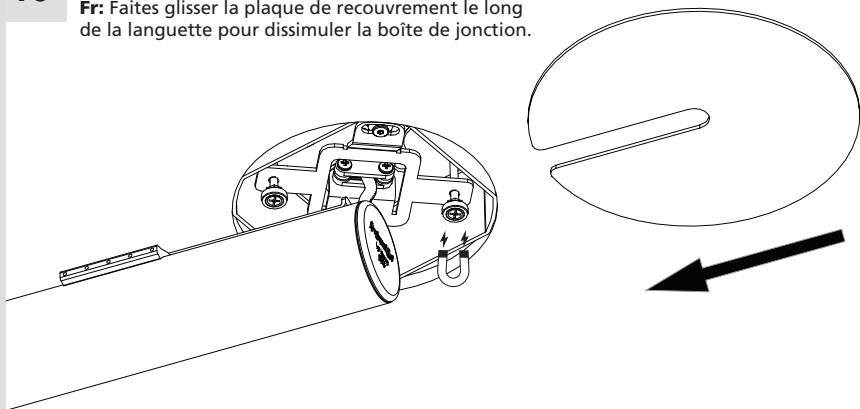

11



Artemide®



Artemide

via Bergamo, 18
20010 Pregnana M.se (MI)
ITALIA

tel. +39 02 935 181
fax +39 02 935 90 254
fax +39 02 935 90 496

www.artemide.com

VAT IT00846890150

Artemide Inc.

250 Karin Lane
Hicksville, NY 11801

Tel. 631 694 9292
Toll Free 1-877-Art-9111
Fax 631 694 9275

www.artemide.net

Artemide Ltée/Ltd.

11105 rue Renaude Lapointe
Montréal, Québec H1J 2T4

Tel. 514 323 6537
Toll Free 888 777 2783
Fax 514 323 8864

www.artemide.net

Y503-13380
Rev. 00
Nov2022