

# INSTALLATION INSTRUCTIONS

Item # N7962-730-L (03/12/2020)

## READ AND SAVE THESE INSTRUCTIONS

**WARNING! SHUT POWER OFF AT FUSE OR CIRCUIT BREAKER.**  
**AVERTISSEMENT! COUPER LE COURANT AU NIVEAU DES FUSIBLES OU DU DISJONCTEUR.**

### MOUNTING THE FIXTURE (Fig.1)

1. Shut off power at the fuse box or circuit breaker box and remove the old fixture including the mounting hardware.
2. Carefully unpack your new fixture and lay out all the parts in a clean area. Take care not to misplace any small parts necessary for installation.
3. Thread the mounting screws (C) half way into the pre-drilled holes in the mounting plate (A) spaced the same distance as the holes in the fixture back plate (D) and secure with nut.
4. Attach mounting plate (A) to the junction box using the screws (B) (Size: #8-32\*0.5L). The side of the mounting plate marked "GND" must face out. It may be necessary to adjust the screw length.
5. The support cable is provided to support the weight of the fixture while wiring. Align the fixture to mounting plate (A) and attach the hook of the support cable into a slot located on mounting plate (A). Carefully allow the support cable to support the weight of the fixture while wiring (Fig.1).

### CONNECTING THE WIRES (Fig. 2)

6. Connect the electrical wires as shown in Fig. 2, making sure that all wire connectors are secured. If your junction box has a ground wire (green or bare copper), connect the fixture's ground wire to it. Otherwise, connect the fixture's ground wire directly to the mounting plate (A) using the green screw provided. After the wires are connected, tuck them carefully inside the outlet box.

### FINISHING THE INSTALLATION (Fig.1)

7. Place fixture back plate (D) over two fixture mounting screws (C) and secure with ball nuts (E).
8. Thread eight (8) glasses (F) onto the branches, which may need adjusting.

Your installation is now complete. Return power to the junction box and test the fixture.

**Note: Illustration on this manual is for installation purposes only. It may or may not be identical to the fixture purchased. Do not clean your light fixture or parts with water or cleanser.**

Fig.1

Set A-020

- Mounting plate
- Ground screw
- Mounting screws (2)

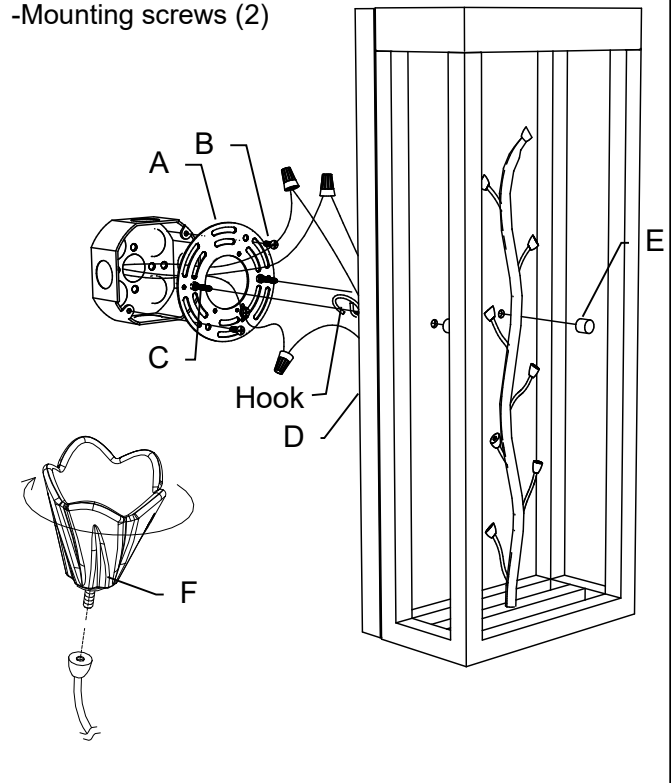
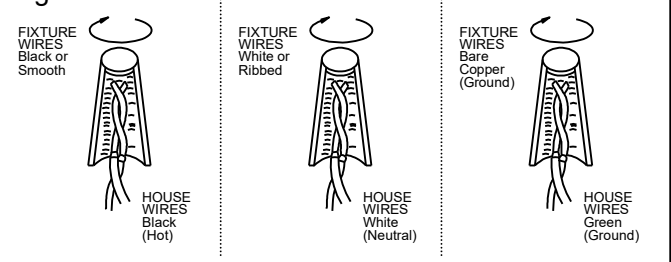

Fig.2



# INSTALLATION INSTRUCTIONS

For AC LED module replacement (17/11/2020)

**READ AND SAVE THESE INSTRUCTIONS**

**WARNING! SHUT POWER OFF AT FUSE OR CIRCUIT BREAKER.  
AVERTISSEMENT! COUPER LE COURANT AU NIVEAU DES FUSIBLES OU DU DISJONCTEUR.**

The LED module can be replaced by a qualified electrician without cutting the wire and without damage to any decorative element to which the fixture is attached.

## PREPARE ACCESSORIES (Fig. 1)

1. Carefully unpack your new AC LED module and lay out in a clean area.
2. Connect the AC LED module to the power supply (AC 120V 60Hz). The AC LED module will light up.

## PREPARE FIXTURE (Fig. 2)

3. Locate the AC LED module needing replacement.
4. Shut off power at the fuse box or circuit breaker box.
5. Take down the fixture and place in a clean area.
6. Loosen screws (G) and remove plate (H).
7. Unplug AC LED module (J) by pressing side tabs and pulling apart both ends.
8. Loosen nuts (I) and remove AC LED module (J).
9. Install the new AC LED module (J).
10. Reverse steps 6-9 for installing the new LED module.

## REPLACEMENT COMPLETED

Return power to the junction box and test the fixture.

**Note: Illustration on this manual is for installation purposes only. It may or may not be identical to the fixture purchased.**

