

LIGHT CHANNEL COMPLETE FIXTURE 0.6" SURFACE MOUNT

24VDC, STATIC WHITE

DESIGNED BY GREGORY KAY | ASSEMBLED IN AMERICA

REV 01.22.24



DESCRIPTION

Light Channel .6" Surface Mount enhances spaces with depth and dimension, seamlessly integrating into the architecture while delivering premium task lighting for applications like under cabinets, bathrooms, work surfaces, and more. Our slim profile, made-to-order LED channel offered in 2, 5, or 7 watts per foot and multiple static white color temperatures from **2400K to 4000K**, with up to 95 CRI, ensuring outstanding color rendering. Available with a diffused white lens or clear lens for maximum light levels, both offered with black or white louver options. Order in 2" or 3" increments from 12" up to 120"(10'). Click here for all [Other Color Temperatures](#). For Field cuttable runs, see DIY spec sheet. Includes a 5-year pro-rated warranty. For custom quotes and layout assistance, send your drawings and ideas to our design team: design@PureEdgeLighting.com.

SPECIFICATIONS

- 24VDC, Class 2
- 2.5, 4.4 or 7.3 watts per foot
- 100° Diffused or Clear Lens
- 2 and 3-inch increments up to 120"(10ft)
- Operating temperature: -22°F to 140°F (-30°C to 60°C)

LENS OPTIONS

- Clear Lens (**C**) provides maximum illumination use of a transparent lens, LEDs diodes will show
- Clear Lens White Louver (**CLW**)
- Clear Lens Black Louver (**CLB**)
- Diffused White Lens (**D**) projects clean lines of light eliminating pixelation
- Diffused Lens White Louver (**DLW**)
- Diffused Lens Black Louver (**DLB**)
- Diffused Lens with Gel Color Filter (**G**) (Provided by Customer) Clear and Diffuser Lens are Gel Color Filter Suitable allowing for color personalization. Zircon LED Gel filters recommended. Purchase Gel Lens from www.leafilters.com. See manufacturer spec sheet for more information.

LAMP

- Offered in multiple Static White Color Temperatures: **2400K, 2700K, 3000K, 3500K & 4000K**
- Lumen Performance: 423lm/ft at 3000K 7W per foot
- 95+ CRI
- Average life: 50,000 hours
- For additional color temperatures refer to other specifications

INCLUDED COMPONENTS

- 72" Power Connector (includes one per fixture). Order extra as needed based on your installation requirements
- Mounting Clips (included with every 2' of Channel)

REMOTE POWER SUPPLIES*, DIMMERS & CONTROLS (SOLD SEPARATELY)

24VDC, Class 2 wiring

- [Pure Smart™ WiZ Pro Power Supplies & Controls](#)
- [UNI Driver: Universal Dimming \(TRIAC, ELV, 0-10V\)](#)
- [Electronic Low Voltage \(ELV\)](#) 50W (fits inside junction box)
- [Lutron](#) Hi-Lume/Ecosystem

*In-wall mounting and drop ceiling kits available for select power supplies

COMPLIANCE

*Title 24 JA8 listed for 2700K CCT and above when used with PureEdge remote Universal power supplies, ETL, Class 2, Damp Location, Made in USA.

APPLICATIONS

Designed for indoor use only. Ideal applications include display shelving and cabinetry, under-cabinet, cabinet lightning, coves, and bars within residential, commercial, retail, and hospitality environments.

Product	Wattage	Nominal Length	Lens	Color Temperature	Finish
LCS.6	2W	60	D	27K	SA
LCS.6 Light Channel .6 Surface Mount	2W 2.5 watts 5W 4.4 watts 7W 7.3 watts	12-120 Available from 12" to 120" in 2" or 3" increments. See chart for exact lengths.	D Diffused Lens C Clear Lens DLW Diffused Lens with White Louver DLB Diffused Lens with Black Louver CLW Clear Lens with White Louver CLB Clear Lens with Black Louver G Diffused Lens with Gel Color (Provided by Customer)	24K 2400K Very Warm White 27K 2700K Incandescent White 30K 3000K Warm White 35K 3500K Neutral White 40K 4000K Cool White	SA Satin Aluminum XX Custom Finishes Available

PROJECT		FIXTURE TYPE		DATE	
---------	--	--------------	--	------	--

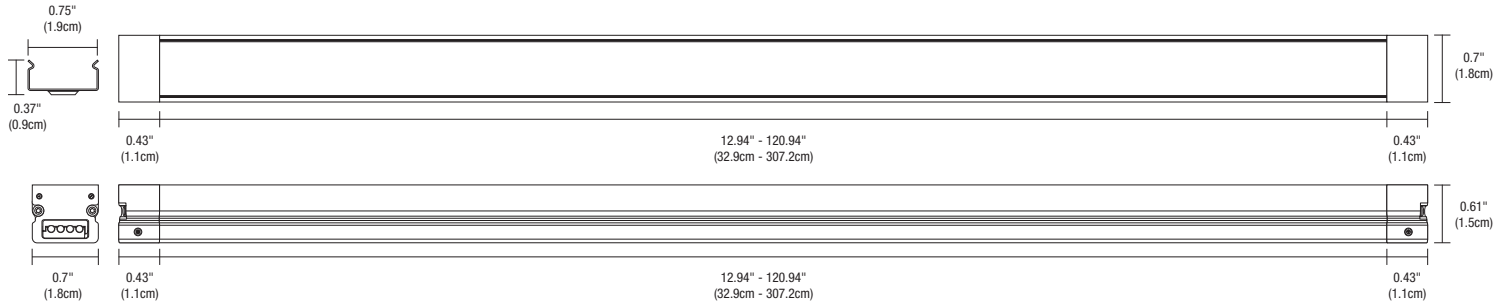

LENS OPTIONS



LCS.6 LIGHT CHANNEL DIFFUSED LENS White Diffuser Lens projects clean lines of light, eliminating pixelation



LCS.6 LIGHT CHANNEL CLEAR LENS Clear Lens provides maximum light levels and will show slight pixelation



LCS.6 LIGHT CHANNEL DIFFUSED WHITE LENS WITH WHITE LOUVER



LCS.6 LIGHT CHANNEL DIFFUSED LENS WITH BLACK LOUVER



LCS.6 LIGHT CHANNEL CLEAR LENS WITH WHITE LOUVER



LCS.6 LIGHT CHANNEL CLEAR LENS WITH BLACK LOUVER



LCS.6 LIGHT CHANNEL DIFFUSED LENS WITH GEL COLOR FILTER (PROVIDED BY CUSTOMER)

Clear and Diffuser Lens are Gel Color Filter Suitable allowing for color personalization. Zircon LED Gel filters are recommended and can be purchased from www.leafilters.com. Gel filter life is 5,000 hours before needing to be changed

FOOT CANDLE CHARTS

30K 100° 5W DIFFUSED LENS		
DISTANCE	BEAM	FOOT CANDLE
12"	29"	240
18"	43"	106
24"	57"	60
36"	86"	26

30K 100° 5W CLEAR LENS		
DISTANCE	BEAM	FOOT CANDLE
12"	8"	720
18"	13"	320
24"	18"	180
36"	26"	80

*Foot Candle Data is based off 4' Channel.

PROJECT		FIXTURE TYPE		DATE	
---------	--	--------------	--	------	--

LIGHT CHANNEL COMPLETE FIXTURE 0.6" SURFACE MOUNT

24VDC, STATIC WHITE

REV 01.22.24

NOMINAL DELIVERED LUMENS

DIFFUSED LENS															
WATTS PER FOOT	2W (2.5 watts)					5W (4.4 watts)					7W (7.3 watts)				
COLOR TEMPERATURE	24K	27K	30K	35K	40K	24K	27K	30K	35K	40K	24K	27K	30K	35K	40K
LUMENS PER FOOT (lm/ft)	120	121	127	145	153	222	225	234	268	283	343	347	361	415	437
LUMENS PER WATT (lm/w)	48	49	51	58	61	51	51	53	61	64	47	48	49	57	60
CRI	90+	95+	95+	85+	85+	90+	95+	95+	85+	85+	90+	95+	95+	85+	85+

CLEAR LENS															
WATTS PER FOOT	2W (2.5 watts)					5W (4.4 watts)					7W (7.3 watts)				
COLOR TEMPERATURE	24K	27K	30K	35K	40K	24K	27K	30K	35K	40K	24K	27K	30K	35K	40K
LUMENS PER FOOT (lm/ft)	141	142	148	170	179	260	263	274	315	332	402	407	423	486	512
LUMENS PER WATT (lm/w)	56	57	59	68	72	59	60	62	71	75	55	56	58	67	70
CRI	90+	95+	95+	85+	85+	90+	95+	95+	85+	85+	90+	95+	95+	85+	85+

WHITE LOUVER CLEAR															
WATTS PER FOOT	2W (2.5 watts)					5W (4.4 watts)					7W (7.3 watts)				
COLOR TEMPERATURE	24K	27K	30K	35K	40K	24K	27K	30K	35K	40K	24K	27K	30K	35K	40K
LUMENS PER FOOT (lm/ft)	94	95	99	113	120	174	175	183	210	221	268	271	282	324	342
LUMENS PER WATT (lm/w)	38	38	40	45	48	39	40	42	48	50	37	37	39	44	47
CRI	90+	95+	95+	85+	85+	90+	95+	95+	85+	85+	90+	95+	95+	85+	85+

WHITE LOUVER DIFFUSED															
WATTS PER FOOT	2W (2.5 watts)					5W (4.4 watts)					7W (7.3 watts)				
COLOR TEMPERATURE	24K	27K	30K	35K	40K	24K	27K	30K	35K	40K	24K	27K	30K	35K	40K
LUMENS PER FOOT (lm/ft)	80	81	84	97	102	148	150	156	179	189	229	231	241	276	291
LUMENS PER WATT (lm/w)	32	32	34	39	41	34	34	35	41	43	31	32	33	38	40
CRI	90+	95+	95+	85+	85+	90+	95+	95+	85+	85+	90+	95+	95+	85+	85+

BLACK LOUVER CLEAR															
WATTS PER FOOT	2W (2.5 watts)					5W (4.4 watts)					7W (7.3 watts)				
COLOR TEMPERATURE	24K	27K	30K	35K	40K	24K	27K	30K	35K	40K	24K	27K	30K	35K	40K
LUMENS PER FOOT (lm/ft)	53	54	56	64	68	99	100	104	119	125	152	154	160	184	194
LUMENS PER WATT (lm/w)	21	22	22	26	27	22	23	24	27	29	21	21	22	25	27
CRI	90+	95+	95+	85+	85+	90+	95+	95+	85+	85+	90+	95+	95+	85+	85+

BLACK LOUVER DIFFUSED															
WATTS PER FOOT	2W (2.5 watts)					5W (4.4 watts)					7W (7.3 watts)				
COLOR TEMPERATURE	24K	27K	30K	35K	40K	24K	27K	30K	35K	40K	24K	27K	30K	35K	40K
LUMENS PER FOOT (lm/ft)	45	46	48	55	58	84	85	88	102	107	130	131	137	157	165
LUMENS PER WATT (lm/w)	18	18	19	22	23	19	19	20	23	24	18	18	19	21	23
CRI	90+	95+	95+	85+	85+	90+	95+	95+	85+	85+	90+	95+	95+	85+	85+

ACTUAL LENGTHS FOR LIGHT CHANNEL .6 SURFACE - STATIC WHITE

Ordering Code (Nominal Size)	Illuminated Length (Inches)	Overall Length (Inches)	Ordering Code (Nominal Size)	Illuminated Length (Inches)	Overall Length (Inches)	Ordering Code (Nominal Size)	Illuminated Length (Inches)	Overall Length (Inches)
12	12.0	12.9	48	48.0	48.9	84	84.0	84.9
15	14.4	15.3	51	50.4	51.3	87	86.4	87.3
17	16.8	17.7	53	52.8	53.7	89	88.8	89.7
20	19.2	20.1	56	55.2	56.1	92	91.2	92.1
22	21.6	22.5	58	57.6	58.5	94	93.6	94.5
24	24.0	24.9	60	60.0	60.9	96	96.0	96.9
27	26.4	27.3	63	62.4	63.3	99	98.4	99.3
29	28.8	29.7	65	64.8	65.7	101	100.8	101.7
32	31.2	32.1	68	67.2	68.1	104	103.2	104.1
34	33.6	34.5	70	69.6	70.5	106	105.6	106.5
36	36.0	36.9	72	72.0	72.9	108	108.0	108.9
39	38.4	39.3	75	74.4	75.3	111	110.4	111.3
41	40.8	41.7	77	76.8	77.7	113	112.8	113.7
44	43.2	44.1	80	79.2	80.1	116	115.2	116.1
46	45.6	46.5	82	81.6	82.5	118	117.6	118.5
						120	120.0	120.9

PROJECT		FIXTURE TYPE		DATE	
---------	--	--------------	--	------	--

LIGHT CHANNEL COMPLETE FIXTURE 0.6" SURFACE MOUNT

24VDC, STATIC WHITE

Light Channel .6 Surface Mount system overview

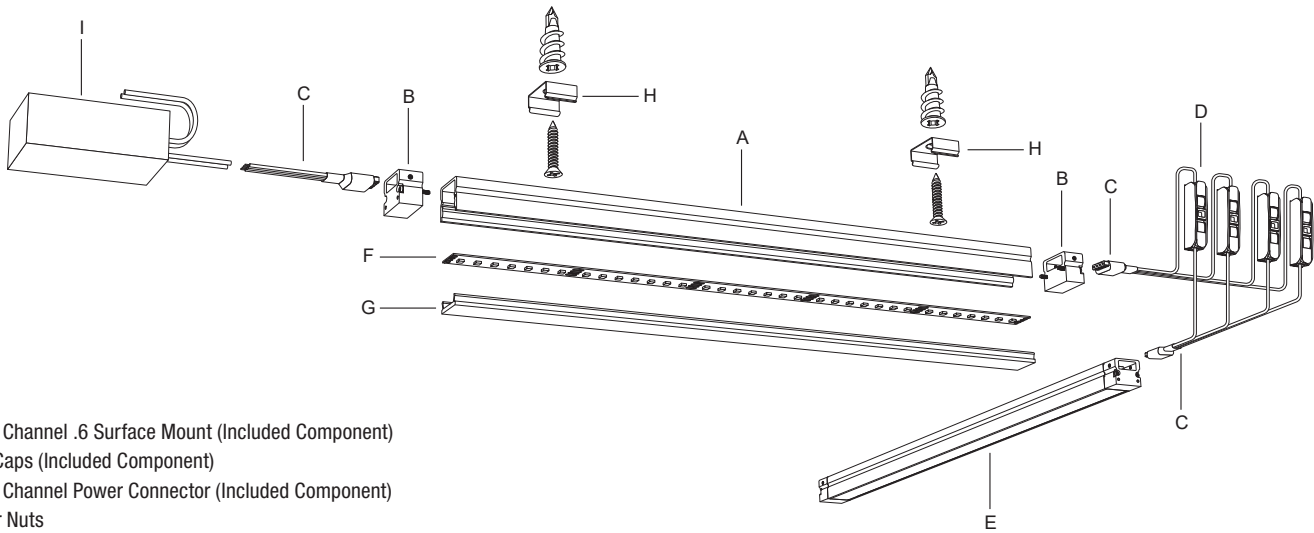

- A. Light Channel .6 Surface Mount (Included Component)
- B. End Caps (Included Component)
- C. Light Channel Power Connector (Included Component)
- D. Lever Nuts
- E. Light Channel .6 Surface Mount Assembly
- F. 24VDC LED Soft Strip (Included Component)
- G. Lens (Included Component)
- H. Mounting Clips (Included Component with every 2' of channel)
- I. Remote Power Supply (PS-60L-ELV-24VDC shown) (Sold Separately)

Wiring Diagram: Electronic Low Voltage (ELV) dimming for Indoor Light Channel .6 Surface Mount

Power Supply: 120VAC input, 24VDC 96 watt output PSB-96W-ELV-24VDC

Dimming: Dimmable with low voltage electronic dimmer using power supply above. See power supply spec sheet for additional details.

Lutron: Diva DVELV-300P; Skylark SELV-300P; Maestro MAELV-600 dimmers are recommended.

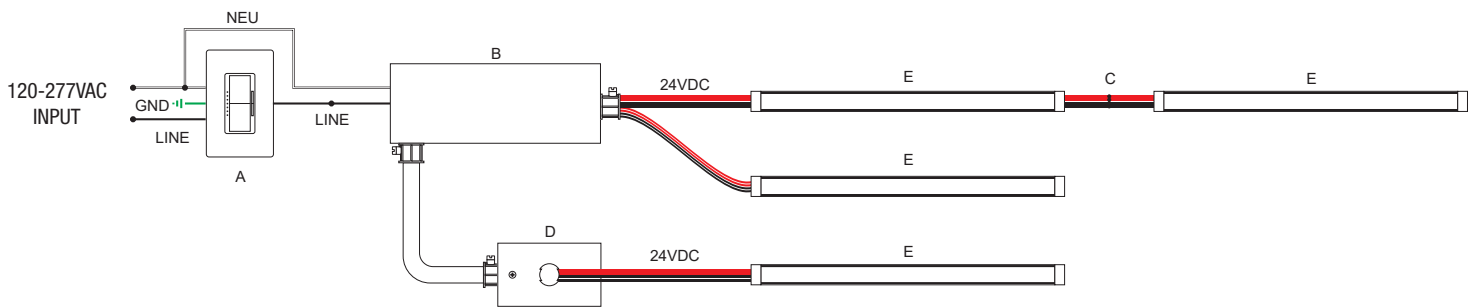

- A. Dimmer (ELV Dimmer shown)
- B. 96W 24VDC Power Supply PSB-96W-UNI-24VDC
- C. Light Channel Power Connector SS-CON-__-DW with Lever Nuts
- D. 3" Rectangle Canopy Cover 3RE-WH
- E. Light Channel Fixture

PROJECT		FIXTURE TYPE		DATE	
---------	--	--------------	--	------	--

ACCESSORIES: Order based on your lighting design specifications or as replacement parts.

LIGHT CHANNEL POWER CONNECTOR

One Female Power Connector is included with each order of channel. For jumper connections, we recommend using WAGO 221 Lever Nuts according to your specific application requirements.

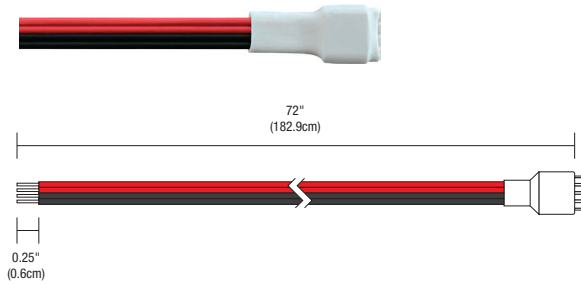

System	Type	Product	Length	Color Temperature
SS	FE	CON	72IN	DW
SS Stomp/Soft Strip	FE Female Pin	CON Connector	72IN 72"	DW Static White

MOUNTING CLIPS

LC-MCL mounting clips are provided with every 2' of Light Channel and may be ordered separately as replacement parts. The LC-MCL-075 rotates Light Channel up to 75 degrees. LC-MCL-90 mounts Light Channel at a 90 degree angle.

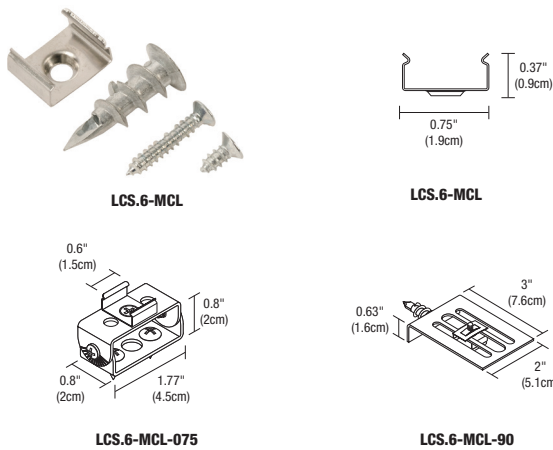

System	Product	Type
LCS.6	MCL	Standard (Leave Blank)
LCS.6 Light Channel 0.6" Surface Mount	MCL Mounting Clip	075 Adjusts 0-75° 90 Adjusts 90°

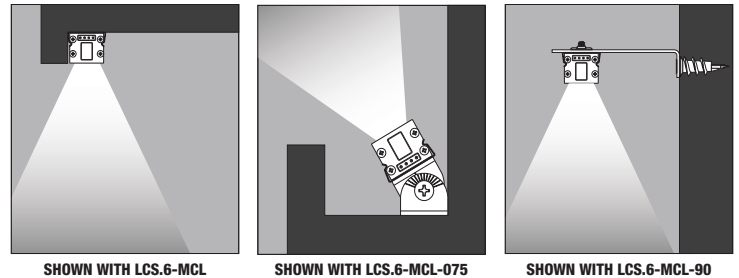

CANOPY COVERS & SPLICE BOXES

Use for remote located power supply. The 3 inch rectangle or 4 inch round white canopy covers the electrical box and feeds wires for Light Channel. The Splice Box provides a safe enclosure for low voltage connections.

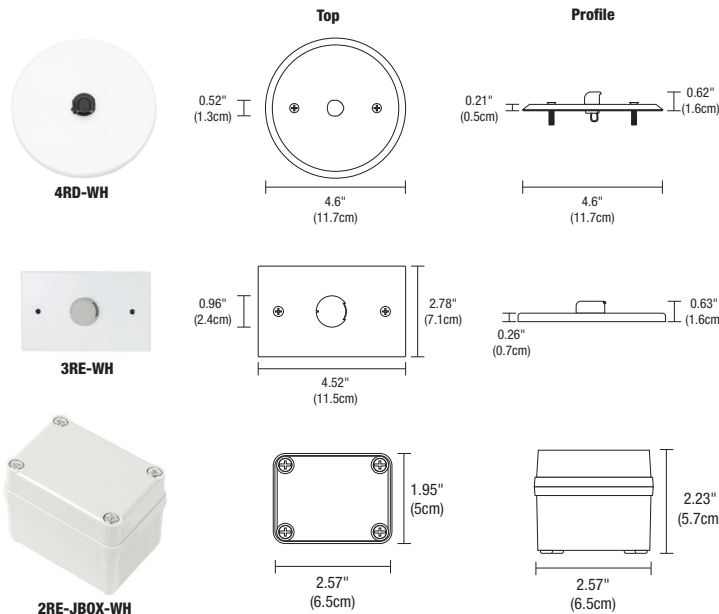

Product	Finish
3RE	WH
3RE 3" Rectangle Canopy Cover	WH White
4RD 4" Round Canopy Cover	
2RE-JBOX 2" Rectangle Splice Box	

PROJECT	FIXTURE TYPE	DATE
---------	--------------	------

LIGHT CHANNEL TM30 DATA

24VDC, STATIC WHITE

TM-30-15 DATA: The data below is for bare LED Static White Strip. Consistent color temperatures throughout a single strip and among multiple strips is possible through a 3 phase binning process in which each order is inspected with a color meter to ensure uniformity.

2400K | Rf: 84.5 | Rg: 94.4

Color Vector Graphic

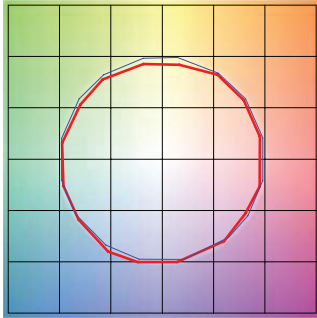

■ Test ■ Reference

HUE BIN	Rf	GRAPHIC SHIFTS %	
		CHROMA	HUE
1	92	-2.4%	1.5%
2	94.7	-2.1%	-0.0%
3	95.4	-1.9%	-0.1%
4	88.7	-6.7%	-3.1%
5	92.8	-5.6%	1.0%
6	92.7	-3.4%	3.4%
7	89.9	-4.3%	4.1%
8	92.4	-1.4%	4.4%
9	89	-0.6%	5.8%
10	88.9	0.4%	6.2%
11	89.7	4.0%	5.4%
12	92.6	3.0%	-0.7%
13	90.9	1.1%	-7.0%
14	89.9	0.5%	-5.8%
15	92.1	-3.2%	0.1%
16	88.9	-1.7%	-6.3%

2700K | Rf: 87.7 | Rg: 96.1

Color Vector Graphic

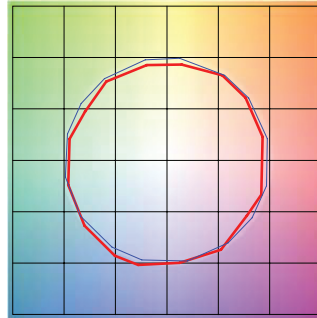

■ Test ■ Reference

HUE BIN	Rf	GRAPHIC SHIFTS %	
		CHROMA	HUE
1	88.0	-4.3%	2.6%
2	91.6	-2.4%	2.0%
3	93.7	-1.4%	1.9%
4	88.9	-5.6%	-3.1%
5	92.3	-5.5%	-0.5%
6	92.9	-3.5%	0.1%
7	84.5	-7.5%	4.6%
8	90.8	-3.0%	4.4%
9	84.5	-1.3%	8.3%
10	83.9	2.0%	9.8%
11	87.2	5.3%	7.1%
12	89.2	5.4%	-2.6%
13	88.7	0.3%	-7.8%
14	86.8	1.7%	-9.3%
15	87.6	-5.4%	-1.3%
16	83.6	-3.3%	-9.5%

3000K | Rf: 88.1 | Rg: 99.7

Color Vector Graphic

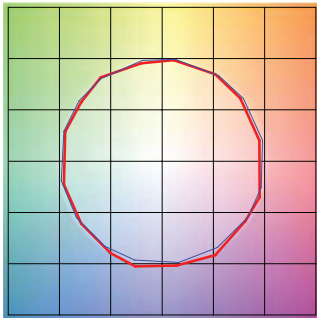

■ Test ■ Reference

HUE BIN	Rf	GRAPHIC SHIFTS %	
		CHROMA	HUE
1	92.5	-3.1%	0.3%
2	93.3	-2.3%	1.9%
3	90.9	-0.8%	3.9%
4	94.3	-1.1%	1.4%
5	92.5	-2.6%	1.5%
6	96.4	1.2%	-0.3%
7	92.6	-2.5%	-0.0%
8	96.9	-1.4%	0.2%
9	92.3	-1.8%	4.3%
10	86.6	-0.7%	7.0%
11	86.5	2.4%	8.2%
12	89.8	5.9%	1.7%
13	93.9	2.6%	-2.7%
14	89.4	5.1%	-5.8%
15	90.1	-0.1%	-4.7%
16	86.5	0.3%	-9.7%

3500K | Rf: 86.1 | Rg: 95.5

Color Vector Graphic

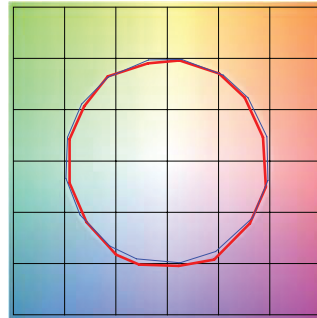

■ Test ■ Reference

HUE BIN	Rf	GRAPHIC SHIFTS %	
		CHROMA	HUE
1	90.8	-3.8%	0.3%
2	92.3	-2.8%	2.1%
3	89.7	-1.0%	4.3%
4	92.6	-1.4%	1.7%
5	91.8	-3.1%	1.3%
6	96.2	0.8%	-0.4%
7	92.9	-3.2%	0.2%
8	94.3	-2.5%	1.5%
9	90.4	-2.5%	5.2%
10	84.3	-1.4%	9.5%
11	83.1	3.5%	9.8%
12	88.2	4.8%	3.4%
13	94.0	2.7%	-2.0%
14	88.7	5.9%	-5.8%
15	88.7	0.7%	-5.9%
16	86.8	-0.7%	-6.7%

4000K | Rf: 87.6 | Rg: 96.8

Color Vector Graphic

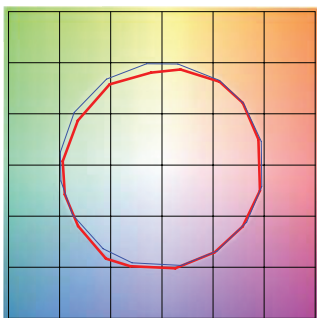

■ Test ■ Reference

HUE BIN	Rf	GRAPHIC SHIFTS %	
		CHROMA	HUE
1	88.9	-2.4%	2.5%
2	93.3	-0.4%	0.8%
3	94.8	-1.0%	-0.6%
4	87.9	-4.9%	-3.6%
5	85.3	-9.4%	-2.6%
6	90.2	-6.0%	0.2%
7	85.3	-7.6%	4.6%
8	83.7	-4.1%	8.2%
9	79.5	-1.1%	13.8%
10	78.6	1.5%	12.1%
11	83.5	6.4%	7.8%
12	90.9	3.6%	-1.1%
13	88.3	1.7%	-6.3%
14	91.9	-0.4%	-2.2%
15	84.5	-0.9%	-5.5%
16	84.7	-1.1%	-4.4%

PROJECT		FIXTURE TYPE		DATE	
---------	--	--------------	--	------	--