

R2FBNT, R2FRNL, R2FSNL, R2FBFT

2" FQ New Construction Housing and Frame-in Kit



SPECIFICATIONS

Input: Universal 120-277V AC 50/60 Hz

Standards: ETL & cETL, IC-rated, Airtight (see below for list), SPCL (Spray Foam Compatible Luminaire), up to R6.8 per inch, as per UL 1598

Dimming: Electronic Low Voltage (ELV): 100%-1%
TRIAC: 100%-1% 0-10V: 100-1%

Emergency: EM fixtures provided with integral Emergency battery back up with 24" lead wire remote test switch. Provides at least 90 minutes of 6W illumination during emergency operation.

Mounting: New construction housings included with universal mounting brackets and hanger bars
Ceiling cutout (Round and Square): Ø 3 1/2"
Ceiling thickness: 1/2" - 1"

Construction: 20 Gauge galvanized sheet

Warranty: 5 year WAC Lighting product warranty

Fixture Type:

Catalog Number:

Project: _____

Location: _____

New Construction Trimmed

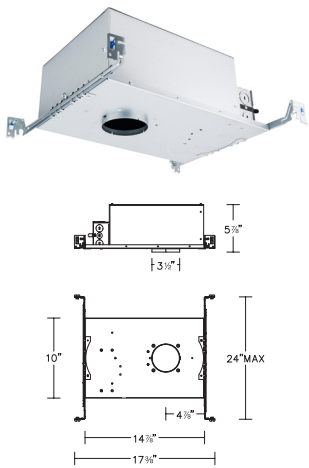

New Construction Trimless

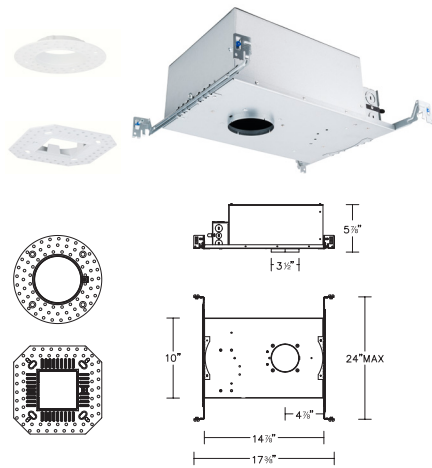

New Construction Frame-In Trimmed

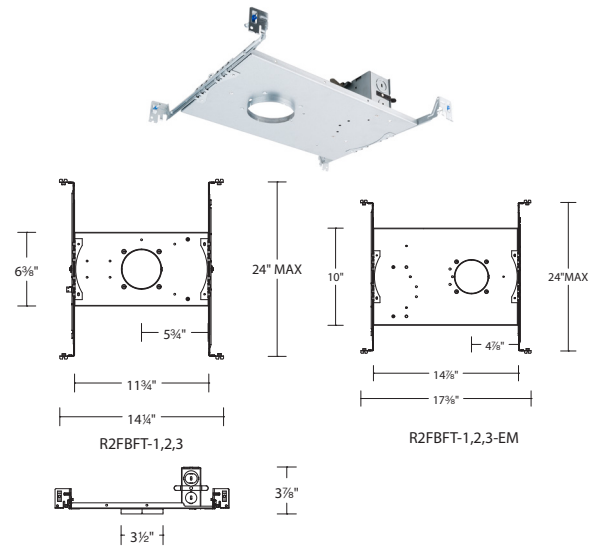

HOUSINGS	Model	Power	Rating	Emergency Backup	Compatible Trims
New Construction Trimmed	R2FBNT Round and Square	Airtight	1 15W IC, SPCL 2 21W IC 3 25W Non-IC	EM* Emergency backup battery (Optional)	R2FRDT, R2FSDT R2FRAT, R2FSAT R2FRWT, R2FSWT
New Construction Trimless	R2FRNL Round (Spackle frame included)	Airtight	1 15W IC, SPCL 2 21W IC 3 25W Non-IC	N/A	R2FRDL, R2FRAL, R2FRWL
	R2FSNL Square (Spackle frame included)	Airtight	1 15W IC, SPCL 2 21W IC 3 25W Non-IC	N/A	R2FSDL, R2FSAL, R2FSWL
New Construction Frame-in Trimmed	R2FBFT Round and Square	Airtight	1 15W Non-IC 2 21W Non-IC 3 25W Non-IC	EM* Emergency backup battery (Optional)	R2FRDT, R2FSDT R2FRAT, R2FSAT R2FRWT, R2FSWT

R2F _ _ _

Example: **R2FBNT-1** or **R2FBNT-1-EM** (with Emergency backup battery)

* EM option is not SPCL rated

wacighting.com	Headquarters, East Manufacturing Facility	South East Manufacturing Facility	Central Manufacturing Facility	West Manufacturing Facility
Phone (800) 526.2588	44 Harbor Park Drive	1600 Distribution Ct	1700 South J Elmer Freeway, Ste 100	1750 S Archibald Ave
Fax (800) 526.2585	Port Washington, NY 11050	Lithia Springs, GA 30122	Cedar Hill, TX 75104	Ontario, CA 91761

R2FBNT, R2FRNL, R2FSNL, R2FBFT

2" FQ New Construction Housing and Frame-in Kit



REPLACEMENT DRIVER

<i>Housing Model</i>	<i>Power</i>		<i>Emergency Backup</i>	<i>Replacement Driver Model</i>
R2FBNT, R2FRNL, R2FSNL	1	15W	None	D-R2FN-1
	2	21W		D-R2FN-2
	3	25W		D-R2FN-3
R2FBFT	1	15W	None	D-R2FF-1
	2	21W		D-R2FF-2
	3	25W		D-R2FF-3
R2FBNT, R2FBFT	1	15W	EM	D-R2FN-1-EM
	2	21W		D-R2FN-2-EM
	3	25W		D-RBFN-3-EM

Example:

For **R2FRNL-2** housing, choose replacement driver model **D-R2FN-2**

For **R2FBNT-3-EM** housing, choose replacement driver model **D-RBFN-3-EM**