

INSTALLATION INSTRUCTION

FQ 2" LED Round Trim

R2FRDT, R2FRDL, R2FRAT, R2FRAL, R2FRPT, R2FRPL, R2FRWT, R2FRWL



WARNING

IMPORTANT: NEVER attempt to do any work without shutting off the electricity.

- Read all instructions before installing.
- System is intended for installation by a qualified electrician in accordance with the National Electrical Code and local regulations.
- Place the wall switch in the "OFF" position.
- Go to the main fuse box, or circuit breaker. Unscrew the fuse(s) or switch "OFF" the circuit breaker switch(es) that control the power to the space that you are working on.

AVERTISSEMENT

IMPORTANT: Coupez l'électricité avant TOUTE manipulation.

- Lisez toutes les instructions avant d'installer.
- Système est destiné à être installé par un électricien qualifié en conformité avec le code national de l'électricité et les règlements locaux.
- Accédez au panneau central de disjoncteurs ou de fusibles de votre demeure et placez l'interrupteur principal en position d'arrêt (« OFF »).
- Placez l'interrupteur mural en position d'arrêt (« OFF »).

CAUTION

All parts must be used as indicated in these instructions. Do not substitute any parts, leave parts out, or use any parts that are worn out or broken. Failure to follow this instruction may invalidate the ETL/cETL listing of this fixture.

TRIM MODEL

Trims R2FRDT, R2FRAT, R2FRPT, and R2FRWT (Fig. A) can be used with remodel, frame-in and new construction housings. Trimless trims R2FRDL, R2FRAL, R2FRPL, and R2FRWL (Fig. B) can be used with remodel and new construction housings. Refer to specification sheets for compatible housings and follow appropriate housing instructions to begin installation.

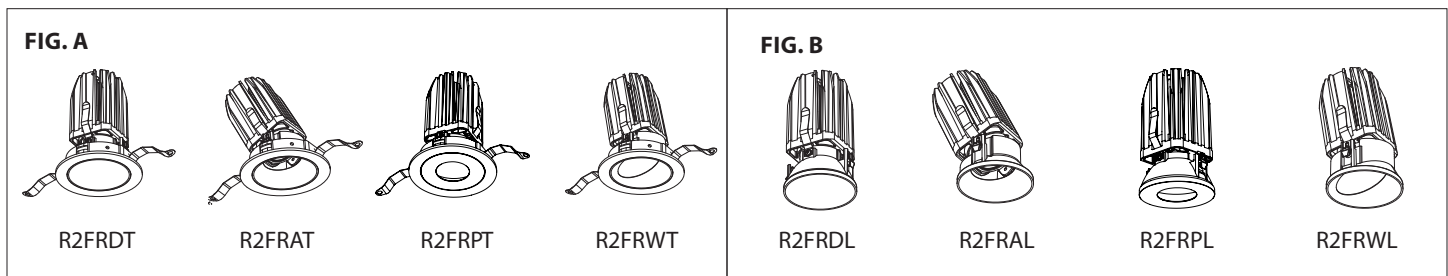

TRIM INSTALLATION (Applies to R2FRDT (featured in all figures), R2FRAT, R2FRPT, R2FRWT)

1. Raise trim assembly to ceiling cutout and connect power connector and safety cable (See FIG.1).
2. Fold trim assembly mounting springs inward and insert trim assembly into ceiling cutout. Be sure once installed, trim assembly is flush and secure (See FIG. 2 & 3).

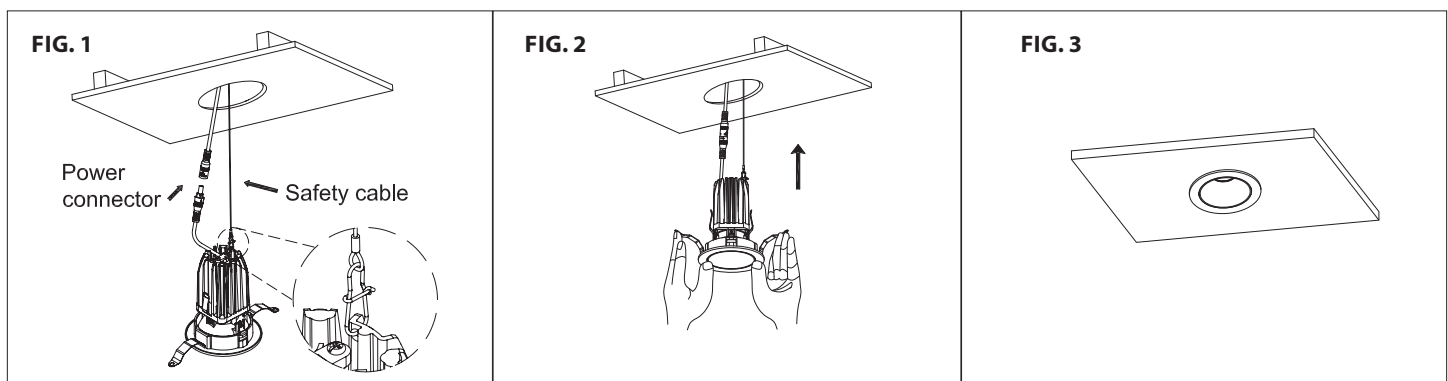

wacighting.com
Phone (800) 526.2588
Fax (800) 526.2585

Headquarters/Eastern Distribution Center
44 Harbor Park Drive
Port Washington, NY 11050

Central Distribution Center
1600 Distribution Ct
Lithia Springs, GA 30122

Western Distribution Center
1750 Archibald Avenue
Ontario, CA 91761

INSTALLATION INSTRUCTION

FQ 2" LED Round Trim

R2FRDT, R2FRDL, R2FRAT, R2FRAL, R2FRPT, R2FRPL, R2FRWT, R2FRWL



TRIMLESS INSTALLATION (Applies to R2FRDL (featured in all figures), R2FRAL, R2FRPL, R2FRWL)

1. Raise trim assembly to ceiling cutout and connect power connector and safety cable (See FIG.4).
2. Insert trim assembly into ceiling spackle ring and engage the trim with spackle ring properly and flush to the ceiling (See FIG. 5, 6).

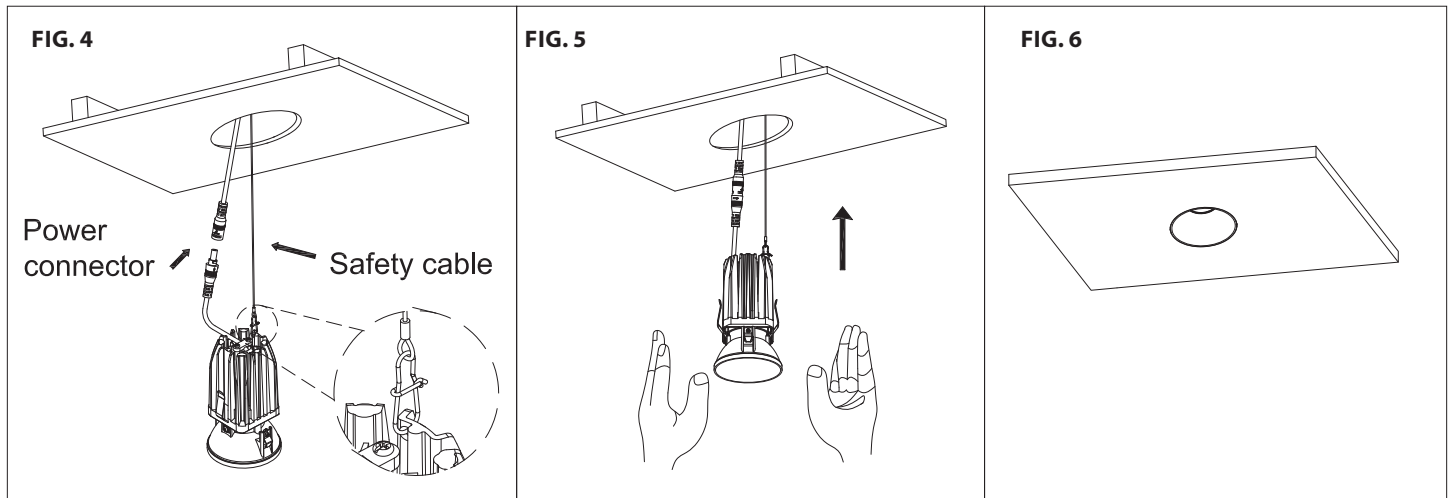

REFLECTOR REPLACEMENT AND ACCESSORY INSTALLATION

1. Remove heatsink from trim assembly (See FIG.7).
2. Select the replacement reflector (See FIG.8).
3. Insert replacement reflector to LED holder.
4. Place one accessory into the trim opening (optional) (See FIG. 8, 9).
5. Reinstall heatsink and trim assembly .

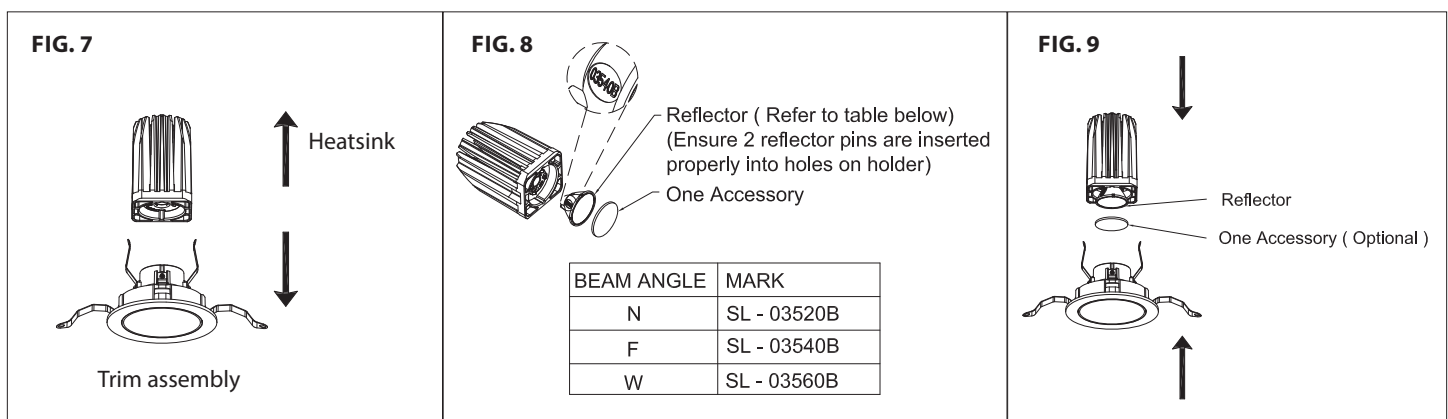

waclighting.com
Phone (800) 526.2588
Fax (800) 526.2585

Headquarters/Eastern Distribution Center
44 Harbor Park Drive
Port Washington, NY 11050

Central Distribution Center
1600 Distribution Ct
Lithia Springs, GA 30122

Western Distribution Center
1750 Archibald Avenue
Ontario, CA 91761

INSTALLATION INSTRUCTION

FQ 2" LED Round Trim

R2FRDT, R2FRDL, R2FRAT, R2FRAL, R2FRPT, R2FRPL, R2FRWT, R2FRWL



REPLACE THE LED ENGINE

1. Power off fixture and let fixture cool down.
2. Remove trim from the trim assembly first, then the trim assembly from the ceiling or fixture aperture (See **FIG. 10**).
3. Disconnect wire connector and safety cable (See **FIG. 11**).
4. Remove the light engine from the trim assembly (See **FIG. 12**).
5. Remove the reflector from the light engine and insert it properly into LED holder of the replacement engine. Install the new engine on the trim (See **FIG. 13**).
6. Connect power connector and safety cable, then reinstall the trim assembly inside fixture to complete (See **FIG. 14**).

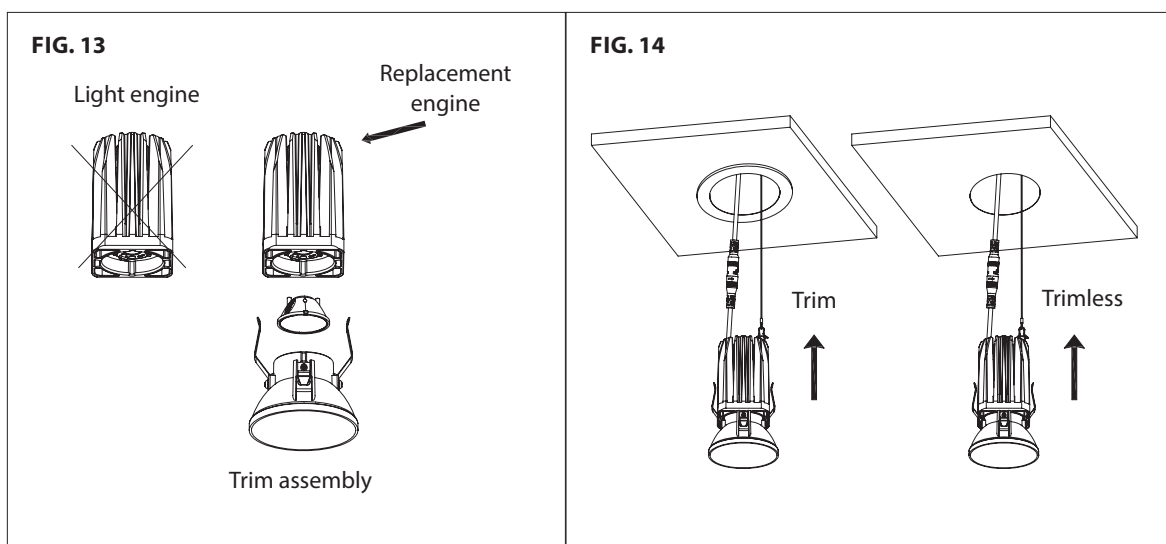
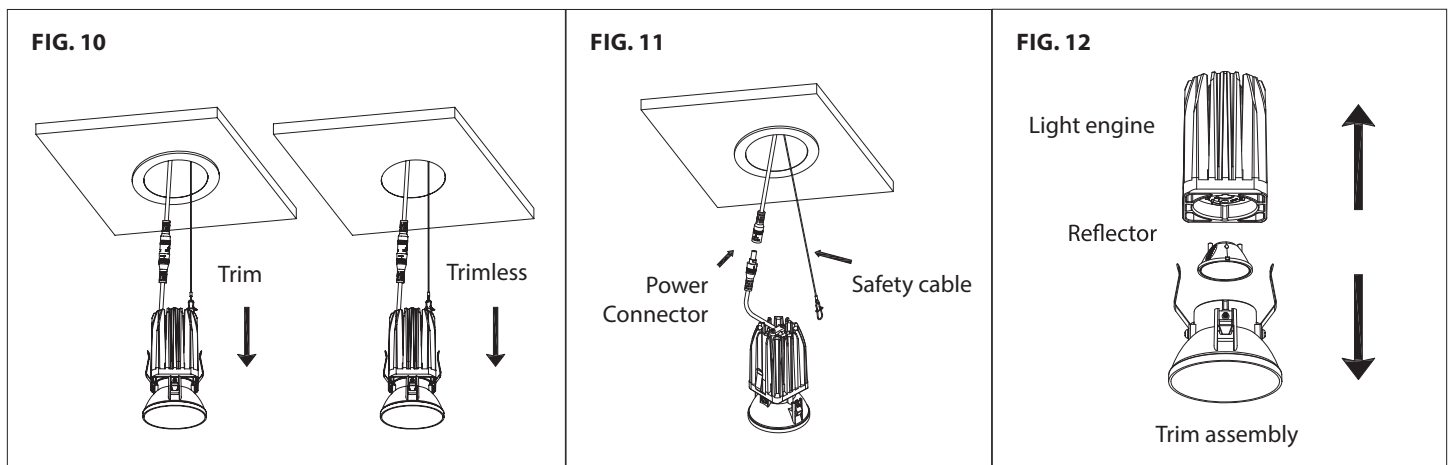

INSTALLATION INSTRUCTION

FQ 2" LED Round Trim

R2FRDT, R2FRDL, R2FRAT, R2FRAL, R2FRPT, R2FRPL, R2FRWT, R2FRWL

WAC

ADJUSTABLE TRIM (APPLIES TO R2FRAT (FEATURED IN ALL FIGURES), R2FRAL)

1. Horizontal Angle Adjustment

Grip the top edge of the adjustable trim and gently rotate the trim to the desired direction (See **FIG. 15**).

FIG. 15



2. Vertical Angle Adjustment

Use a finger to reach the reflector ring and gently push forward or backward to achieve the desired tilting angle (See **FIG. 16**). For achieving the maximal tilting angle, adjust trim flange orientation to ensure the two mounting springs don't interfere with vertical tilting (See **FIG. 17**).

FIG. 16

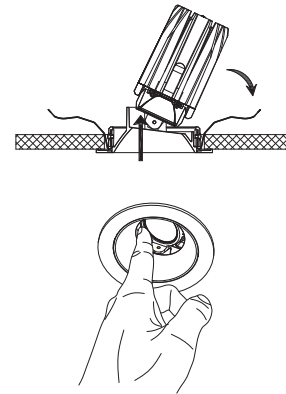
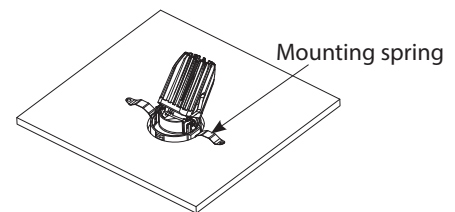

FIG. 17



WALL WASH TRIM (APPLIES TO R2FRWT (FEATURED IN ALL FIGURES), R2FRWL)

1. Aiming Wall Wash Trim to the desired Wall

Rotate the the Wall Wash trim to have the sloped lens facing the lighted wall (See **FIG. 18**).

FIG. 18

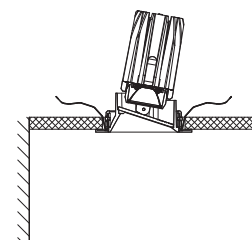

2. Remove Wall Wash Trim From Fixture

Insert the tip of a small flat screw driver into the notch on the top the trim and gently pull down the trim (See **FIG. 19**). Take care or add protection padding to avoid damaging trim finish.

FIG. 19

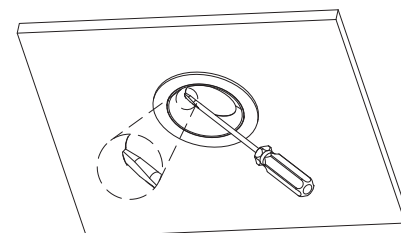

waclighting.com
Phone (800) 526.2588
Fax (800) 526.2585

Headquarters/Eastern Distribution Center
44 Harbor Park Drive
Port Washington, NY 11050

Central Distribution Center
1600 Distribution Ct
Lithia Springs, GA 30122

Western Distribution Center
1750 Archibald Avenue
Ontario, CA 91761