

Ring

Ilmiodesign

Ring S1

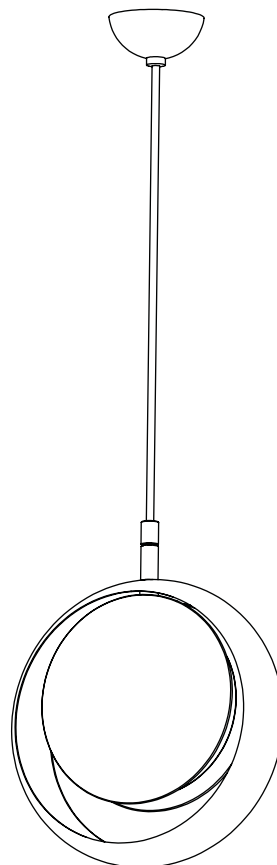

ADVERTENCIAS

- Se recomienda que la instalación sea realizada por un profesional.
- Desconectar la conexión a red antes de ser manipulada.
- Si el cable de la luminaria está dañado, deberá sustituirse exclusivamente por el fabricante o su servicio técnico.
- Para limpiar la luminaria, utilizar un paño suave humedecido con agua y, si fuera necesario, detergente neutro. No usar alcohol u otros disolventes.
- Para la opción de regulación con Casambi, descargar la aplicación. Para más información ir a la web www.casambi.com

WARNINGS

- The light should be installed by a professional electrician.
- Disconnect from the power system before handling the light.
- If the lamp cable is damaged, it should only be replaced by the manufacturer or its technical service.
- To clean the lamp, use a soft cloth dampened with water and, if necessary, neutral soap. Do not use alcohol or other solvents.
- To use the dimming option with Casambi, please download the app. For more information, visit www.casambi.com

HINWEISE

- Wir empfehlen, die Installation von einem Fachmann vornehmen zu lassen.
- Unterbrechen Sie die Verbindung zum Netz vor Beginn der Arbeiten.
- Wenn das Kabel der Leuchte beschädigt ist, darf es ausschließlich vom Hersteller oder dessen technischem Dienst ausgewechselt werden. ausgetauscht werden, um jedwedes Risiko zu vermeiden.
- Zur Reinigung der Leuchte empfiehlt es sich, ein weiches, mit Wasser und, falls nötig, neutralem Reinigungsmittel befeuchtetes Tuch zu verwenden. Keinen Alkohol oder andere Lösungsmittel verwenden.
- Für die Anwendung des Licht-Kontroll-Systems Casambi die App herunterladen. Für weitere Informationen besuchen Sie die Webseite www.casambi.com

1.

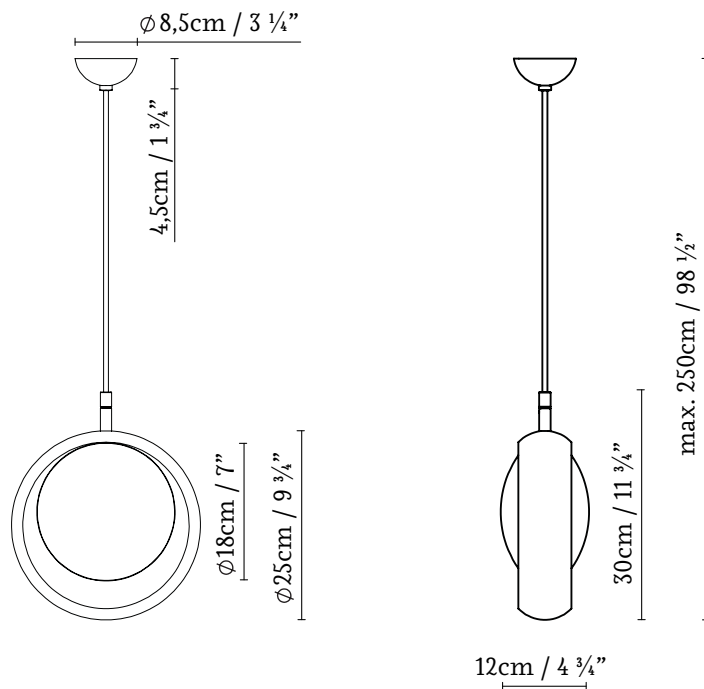

2.

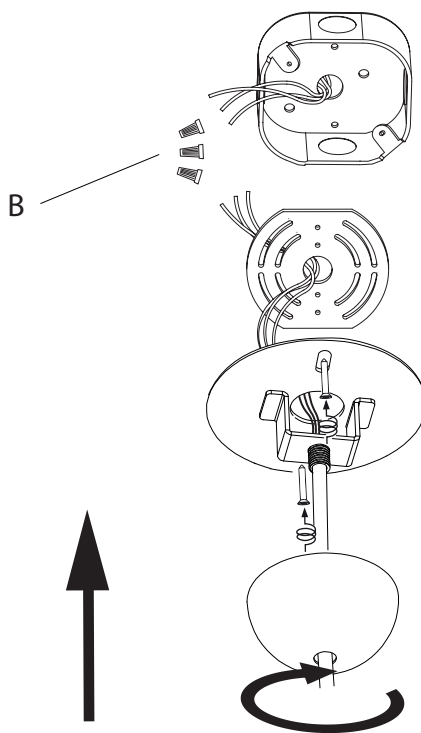

1. General dimensions.

2. Make the connections (B) and secure the lamp using two studs.

3.

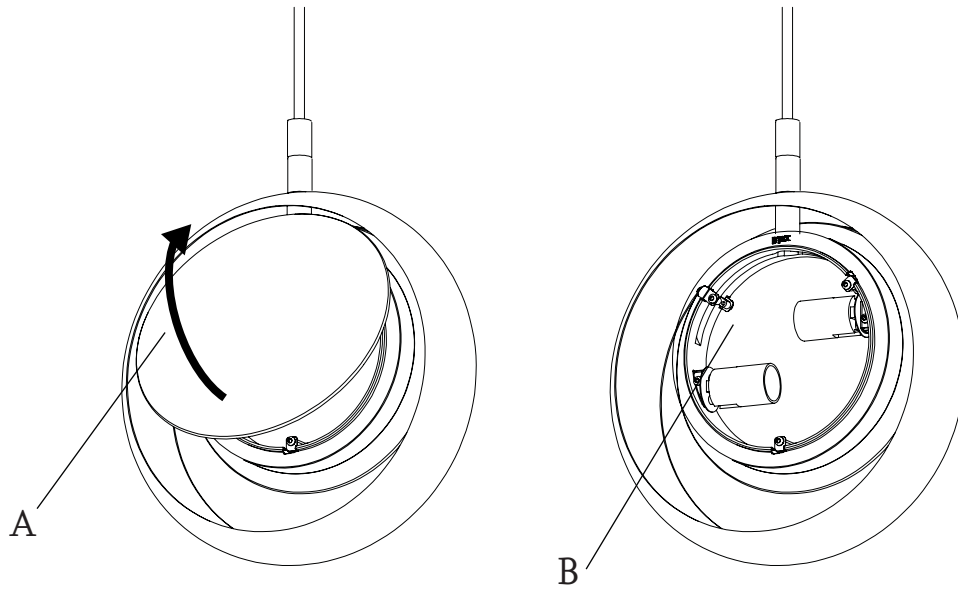

4.

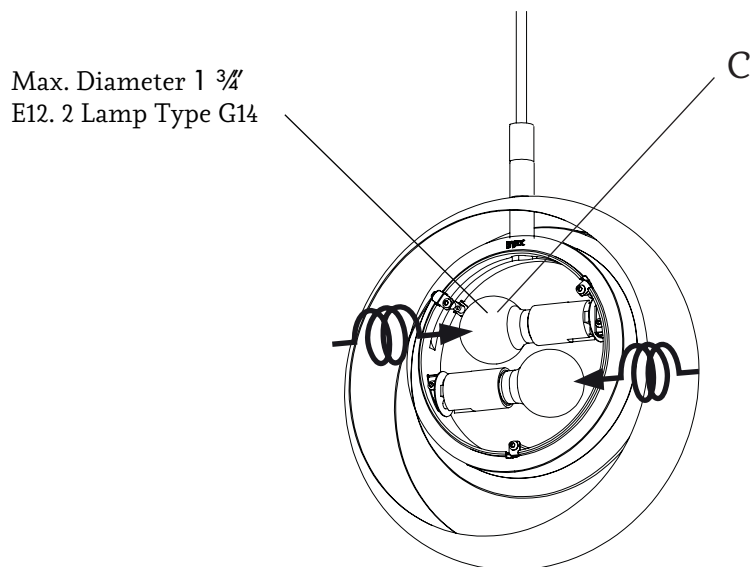

3. Release a glass piece (A) by pulling from the bottom out. The lamp holder (B) will now be visible.
4. Screw in the two light bulbs (C).

5.

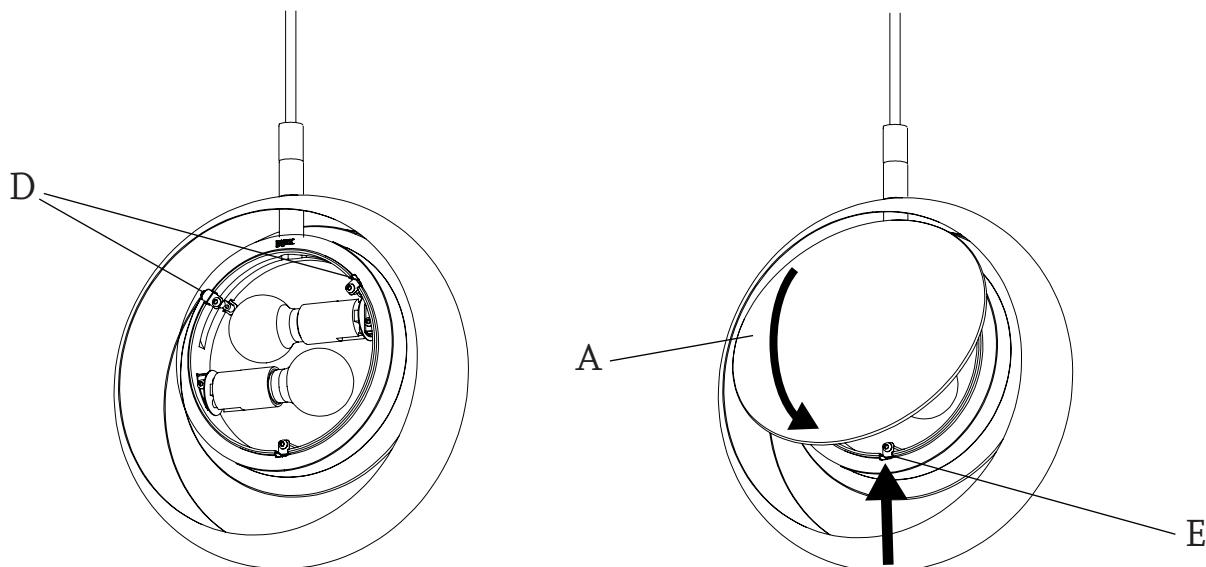

6.

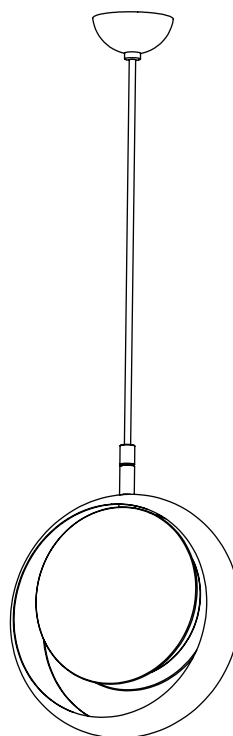

5. Carefully replace the glass piece (A).
First align the two upper clamps (D) on the inside of the glass. Finish replacing the glass by pressing the lower clamp (E) with a finger until it moves into position and supports the glass.
6. The light fitting is ready to be switched on.

Ring

Ilmiodesign

Ring S6

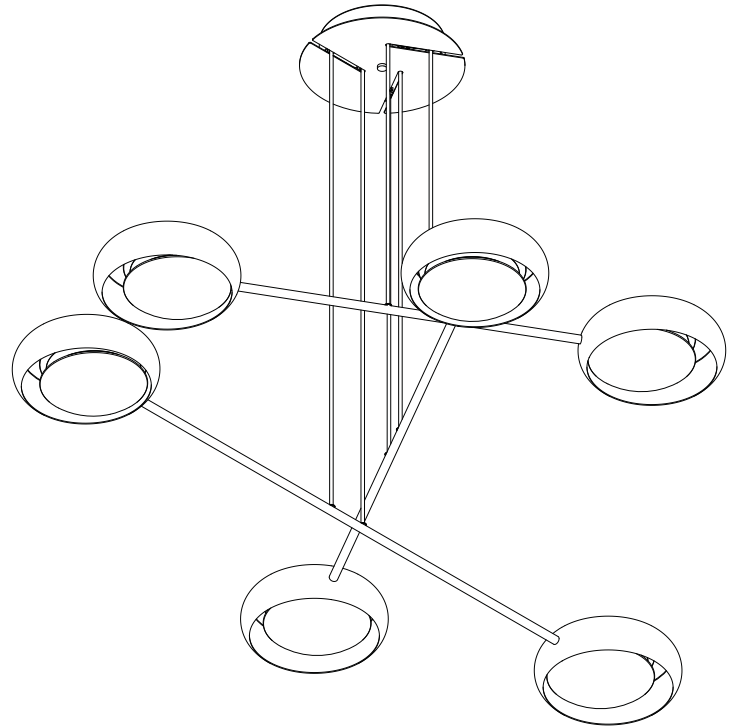

ADVERTENCIAS

- Se recomienda que la instalación sea realizada por un profesional.
- Desconectar la conexión a red antes de ser manipulada.
- Si el cable de la luminaria está dañado, deberá sustituirse exclusivamente por el fabricante o su servicio técnico.
- Para limpiar la luminaria, utilizar un paño suave humedecido con agua y, si fuera necesario, detergente neutro. No usar alcohol u otros disolventes.
- Se recomienda que la instalación sea realizada como mínimo entre dos personas.
- Para la opción de regulación con Casambi, descargar la aplicación. Para más información ir a la web www.casambi.com

WARNINGS

- The light should be installed by a professional electrician.
- Disconnect from the power system before handling the light.
- If the lamp cable is damaged, it should only be replaced by the manufacturer or its technical service.
- To clean the lamp, use a soft cloth dampened with water and, if necessary, neutral soap. Do not use alcohol or other solvents.
- The light should be installed by at least two people.
- To use the dimming option with Casambi, please download the app. For more information, visit www.casambi.com

HINWEISE

- Wir empfehlen, die Installation von einem Fachmann vornehmen zu lassen.
- Unterbrechen Sie die Verbindung zum Netz vor Beginn der Arbeiten.
- Wenn das Kabel der Leuchte beschädigt ist, darf es ausschließlich vom Hersteller oder dessen technischem Dienst ausgewechselt werden. ausgetauscht werden, um jedwedes Risiko zu vermeiden.
- Zur Reinigung der Leuchte empfiehlt es sich, ein weiches, mit Wasser und, falls nötig, neutralem Reinigungsmittel befeuchtetes Tuch zu verwenden. Keinen Alkohol oder andere Lösungsmittel verwenden.
- Wir empfehlen, die Installation von mindestens zwei Personen durchführen zu lassen.
- Für die Anwendung des Licht-Kontroll-Systems Casambi die App herunterladen. Für weitere Informationen besuchen Sie die Webseite www.casambi.com

1.

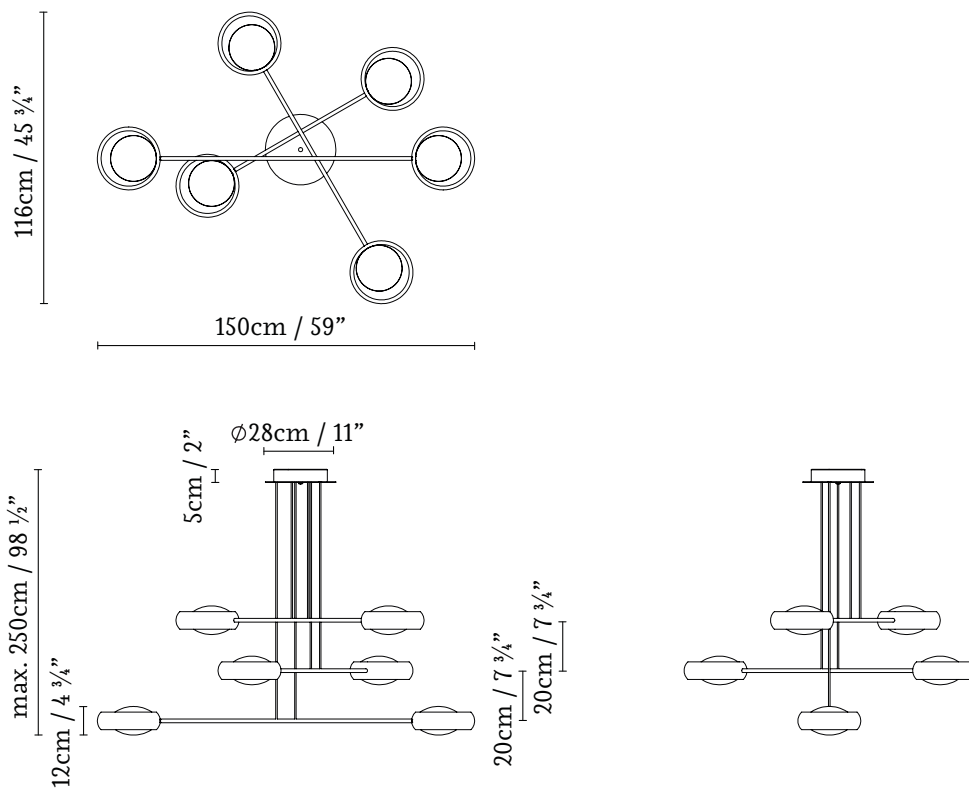

2.

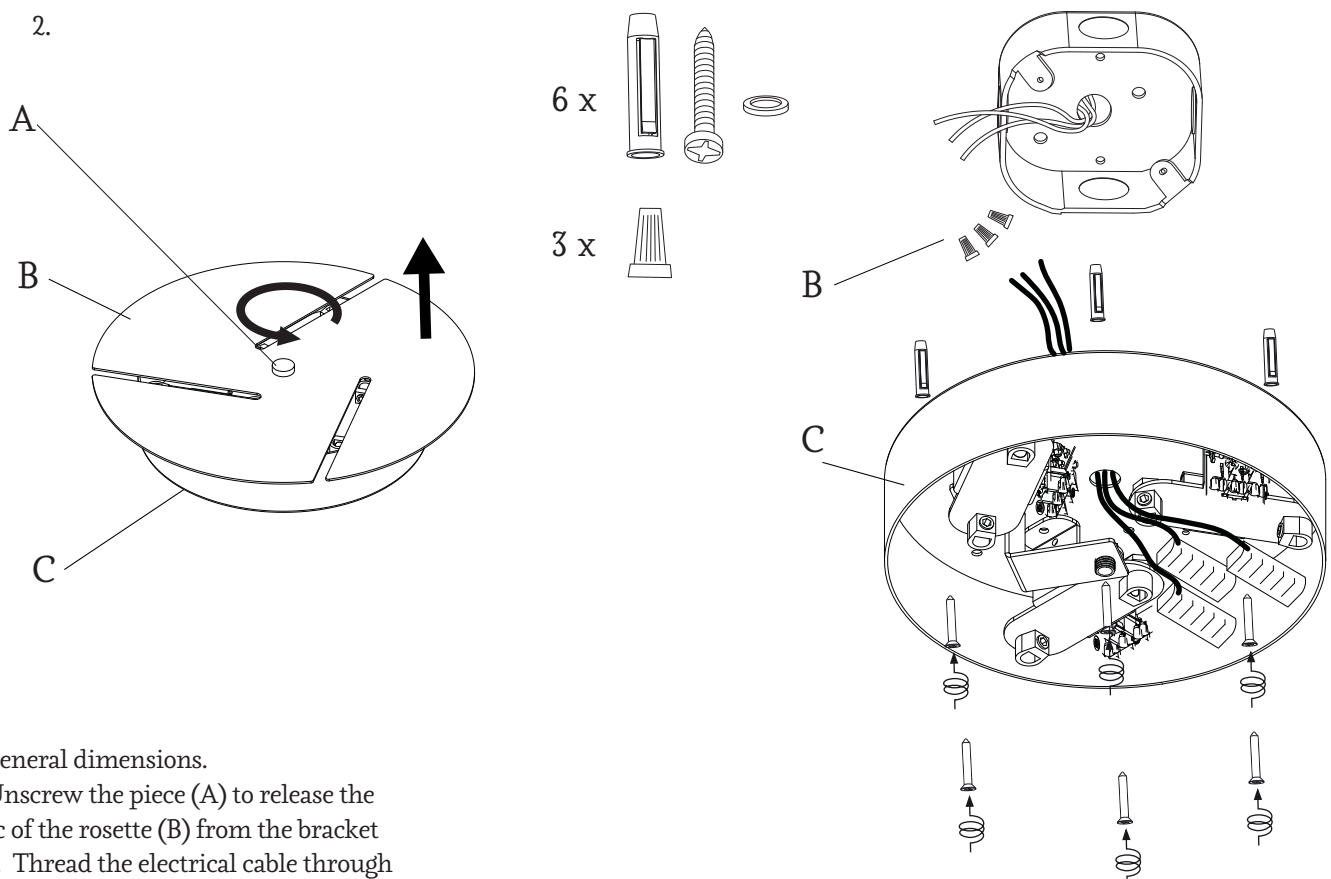

1. General dimensions.

2. Unscrew the piece (A) to release the disc of the rosette (B) from the bracket (C). Thread the electrical cable through the hole in the bracket (C). Make the connections (B) and tie the lamp to the surface using the studs, washers and screws supplied.

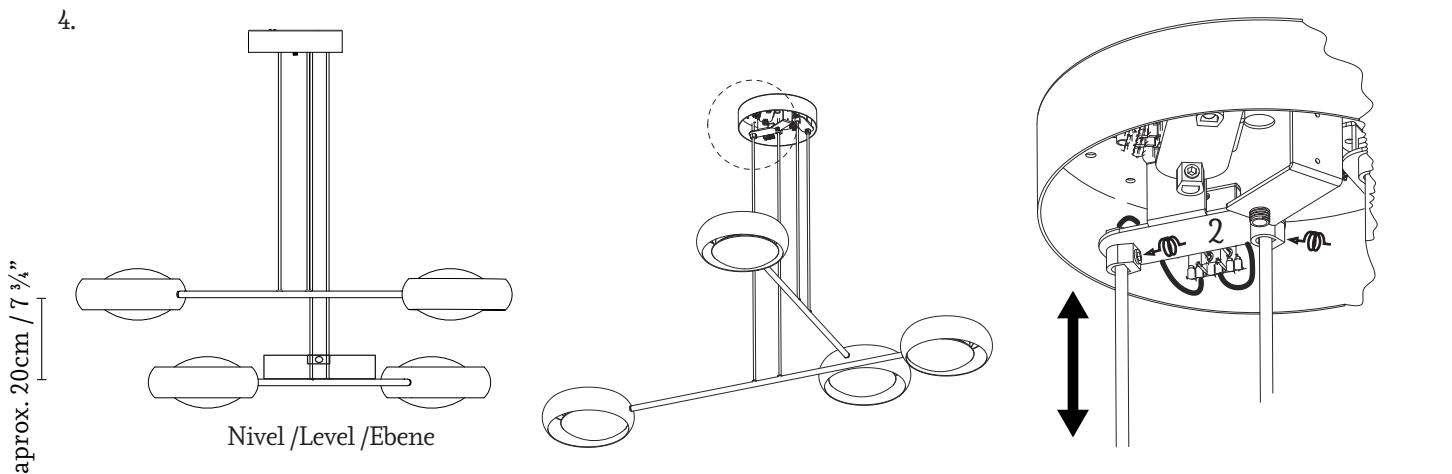
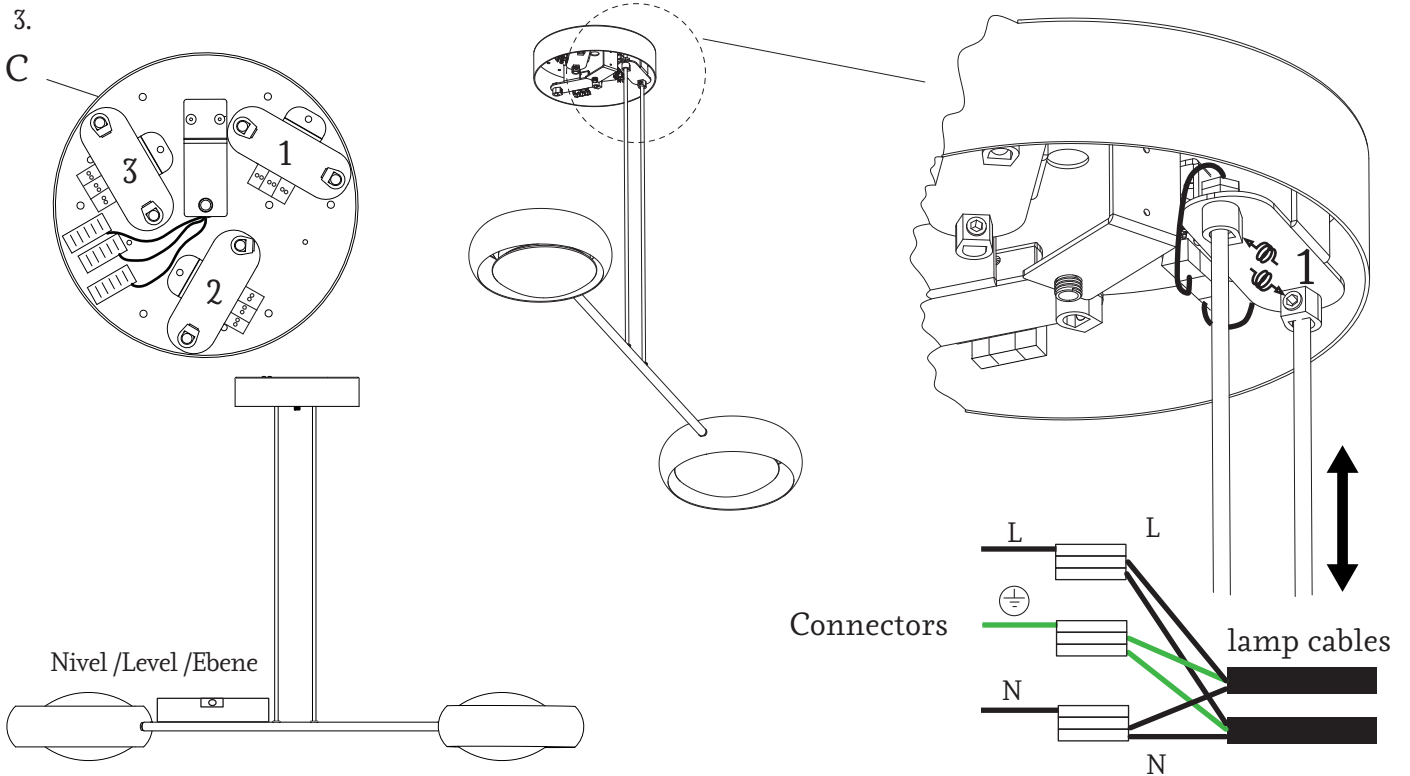

3. Install the Ring suspension parts, one in each of the three bases of the bracket (C). The first suspension part to be installed can be the longest or the shortest, as preferred. Place the first suspension part on the base, level the height, tighten the cable locks and make the connection.

4. Place the second suspension part in the bracket. This will always be the intermediate-length bar. Level the height, tighten the cable locks and make the connection.

5.

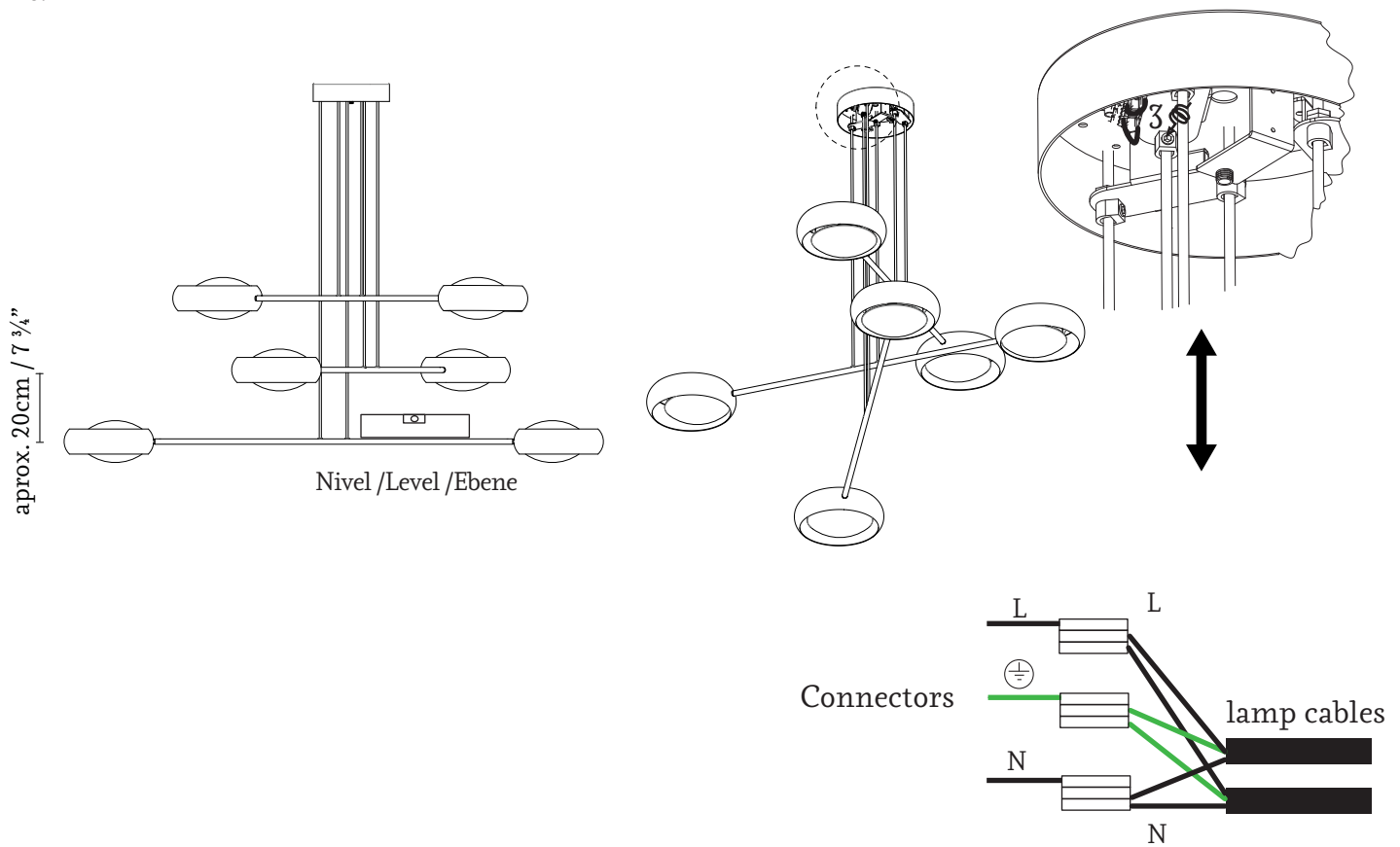

5. Place the third suspension part in the bracket, leaving a distance between them. Level the height, tighten the cable locks and make the connection.

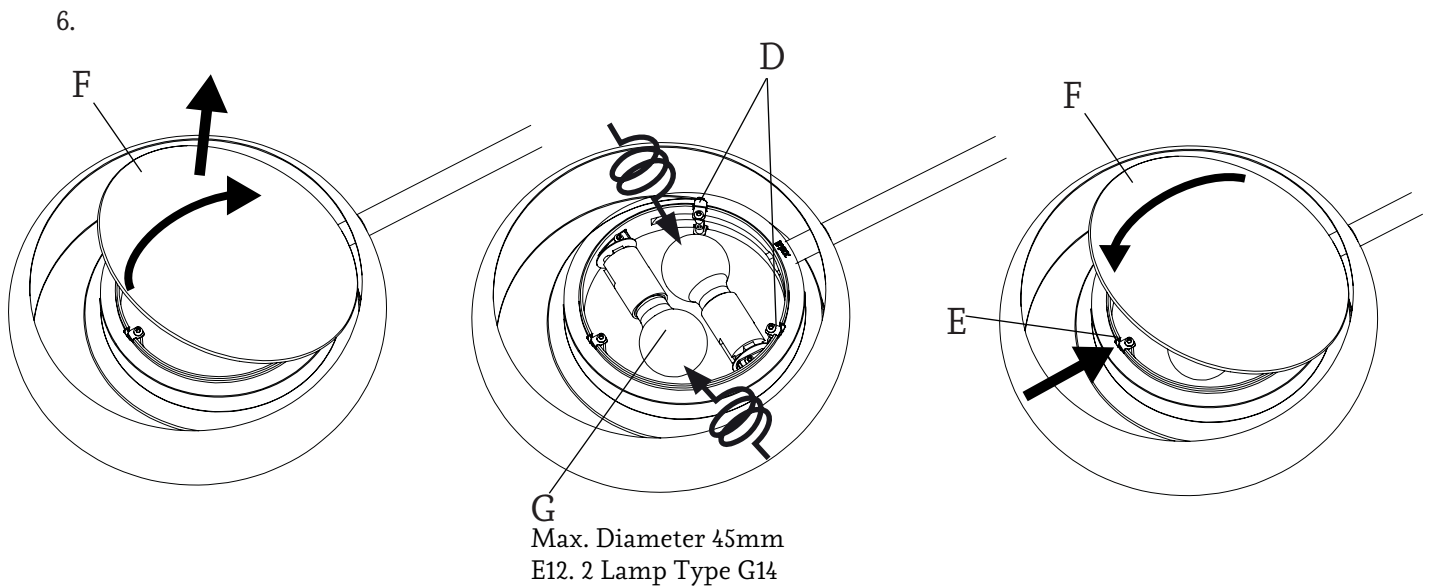

7.

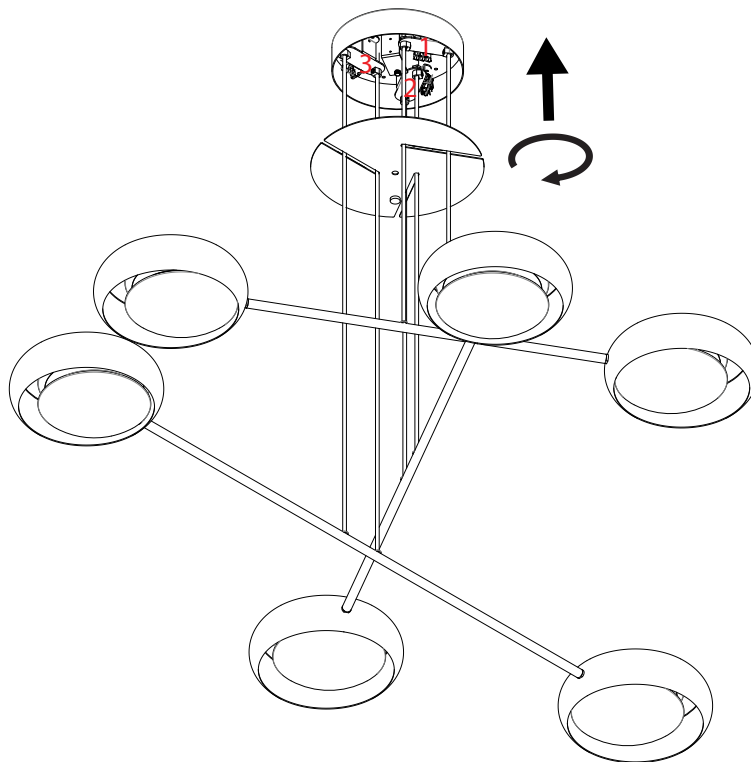

6. Release the glass (F), install the light bulbs (G) and then carefully replace the glass (F). First align the two upper clamps (D) on the inside of the glass. Finish replacing the glass by pressing the lower clamp (E) with a finger until it moves into position and supports the glass.

7. Install the trim, bearing in mind the position shown in point 1. The light fitting is ready to be switched on.

Lamps without the IP mark are classed as IP20 and are designed for general indoor use, except wet areas (bathrooms, etc.)

- Lamps with the IP mark are designed for outdoor use and in wet areas. (E.g. IP54)
- They offer guaranteed protection to people and animals against electric shocks:

Class I: through single electrical insulation and an earthing conductor once correctly connected.



Class II: through double electrical insulation.



Class III: these kinds of lamps should be connected at very low voltage levels (generally 12V); therefore there is no risk.



• Lamps with this symbol, or without any symbols, can be mounted directly onto normally inflammable surfaces.



• Lamps with this symbol cannot be mounted directly onto normally inflammable surfaces.

• The safety of this lamp is guaranteed by using a maximum wattage bulb that does not exceed the figure displayed visibly on the lamp.



• The product cannot be treated like conventional domestic waste; it must be taken to the appropriate recycling station for electrical and electronic equipment.