

Dependant 3 & 5

Accessories

**louis
poulsen**

Design Louis Poulsen

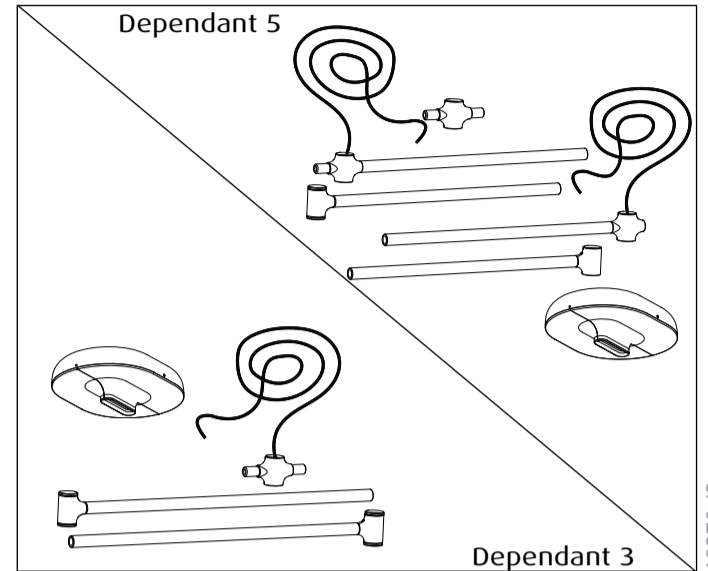
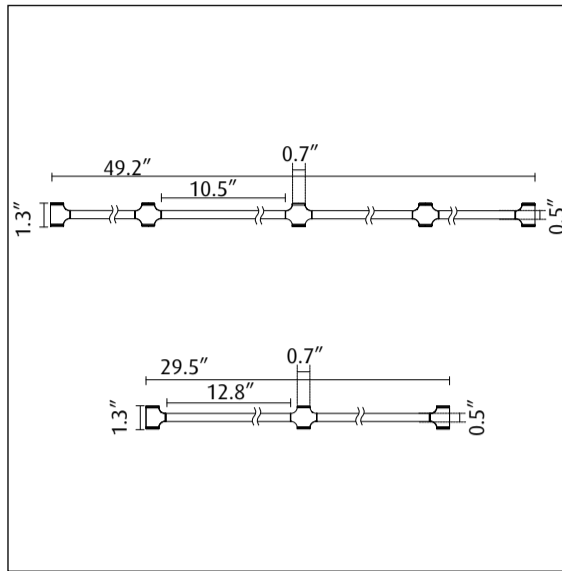
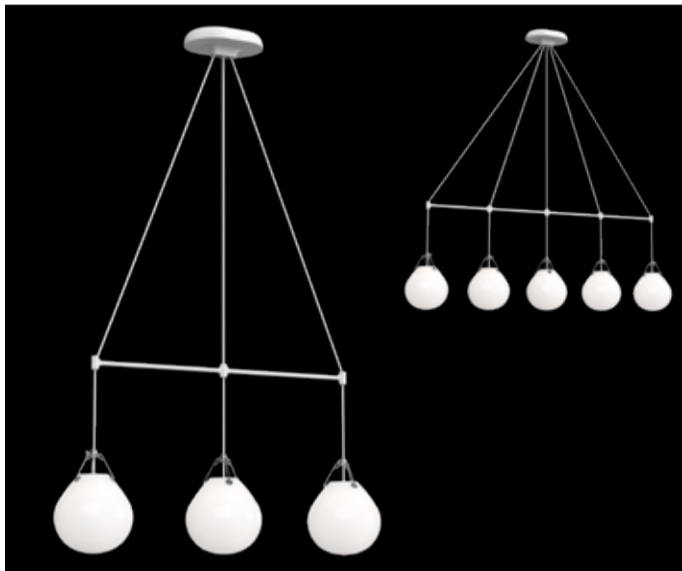

Max Wattage	Voltage	Weight	Ingress protection
Max. 100W pr. luminaire	120V, 50-60Hz	Dependant 3: 1,1 kg 2.4 lbs Dependant 5: 1,2 kg 2.6 lbs	IP 20 Dry location

Recommended cleaning substances:

Wipe off dust with a dry, soft cloth. Remove greasy spots etc. with a soft cloth dampened in lukewarm water (<122° F/ 50° C) with a mild detergent. Never use detergents containing abrasives and solvents.

Warning: Scouring powder and similar substances will scratch surfaces.

All installation is subject to local code and jurisdiction.

Consult a qualified electrician to ensure correct branch circuit conductor. The installer must ensure that the ceiling can support the luminaire's weight. The installer must if necessary reinforce the ceiling structure by adequate means.



Due to possibility of personal injury or property damage, always contact a qualified electrician for servicing or repair of this fixture. To avoid risk of electrical shock, personal injury, or death, disconnect power to fixture before servicing.

Cord Strain relief suitable for 18 AWG three conductor SJT or two conductor SVT or SVT-B Cord	
Not Hard Usage Jacketed Cable:	Max 2,3kg (5Lbs) Per Luminaire
Hard Usage Jacketed Cable:	Max 4.5kg (10lbs) Per Luminaire
Dependant is for cord hanged pendant only	
Overall weight of system must not exceed 22.7kg(50lbs)	

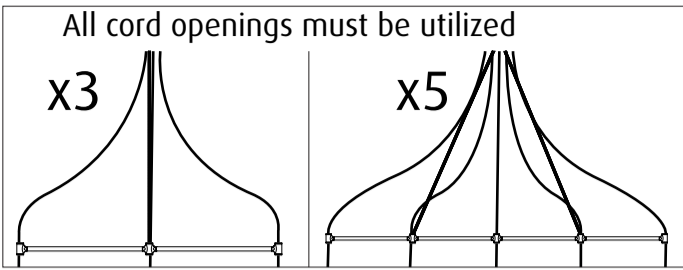
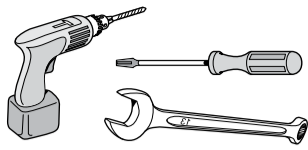
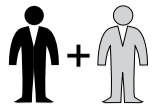
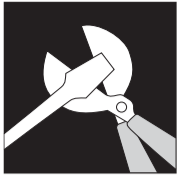

18370-12

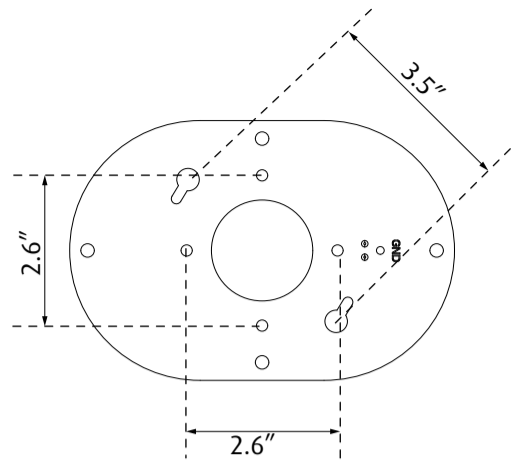

A

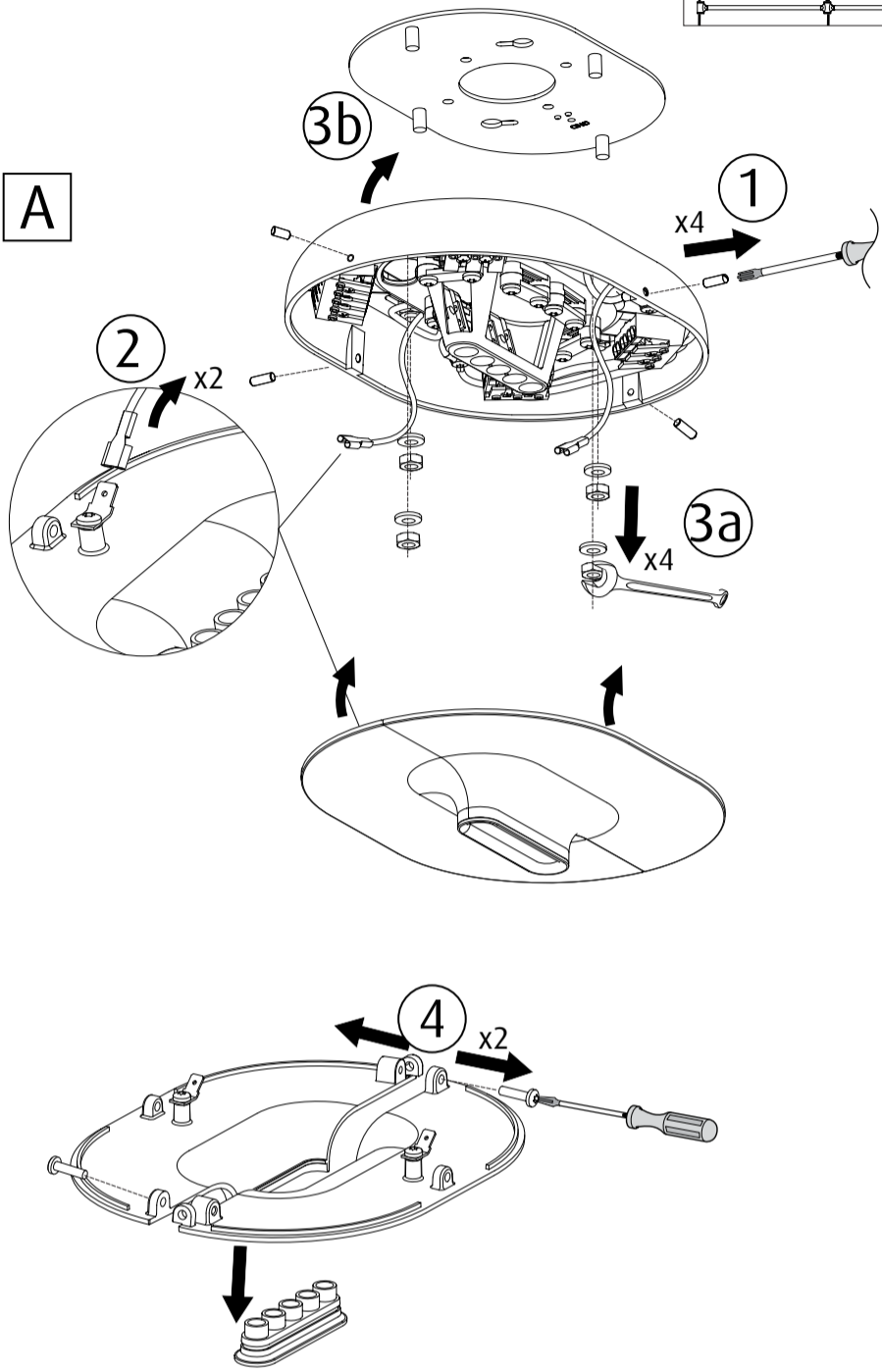

B

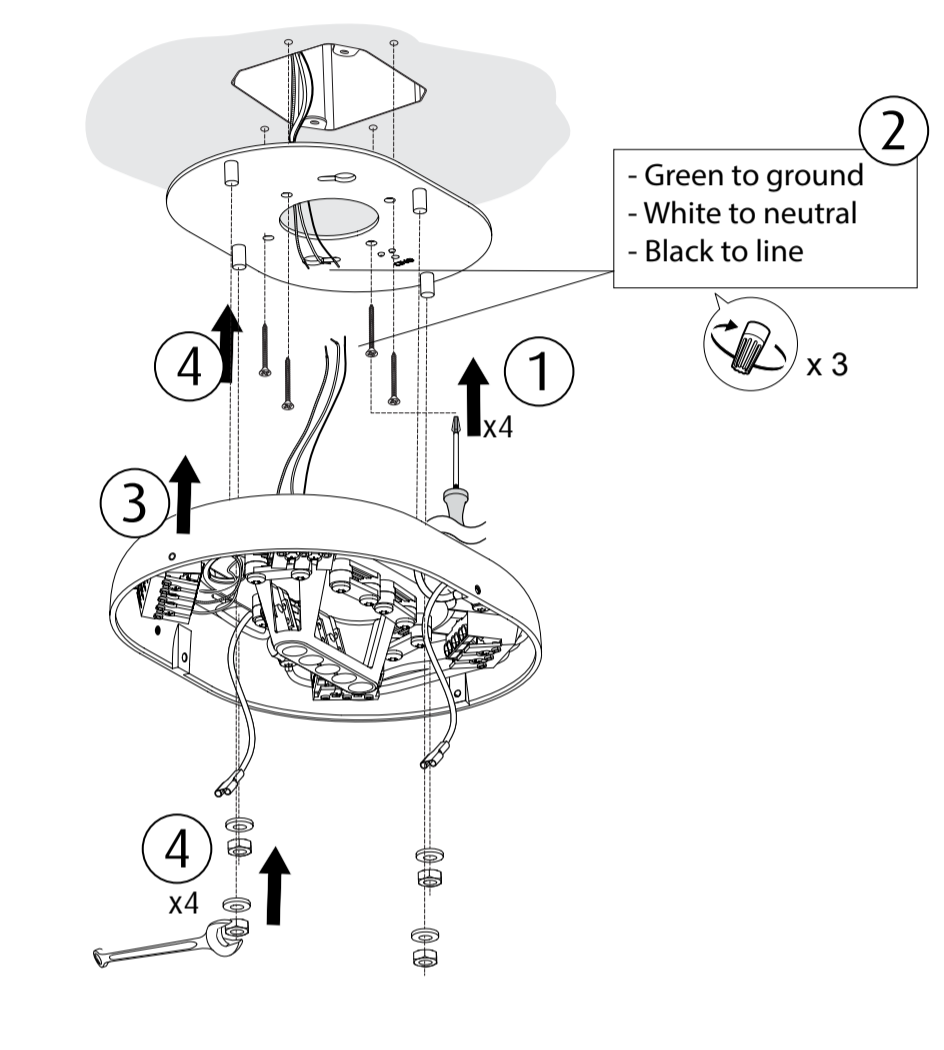

C

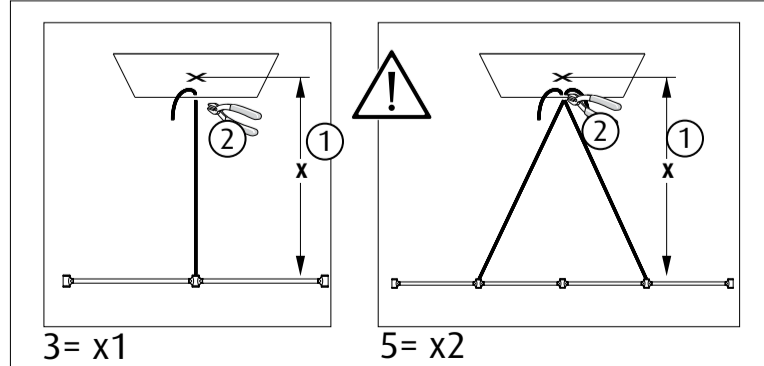
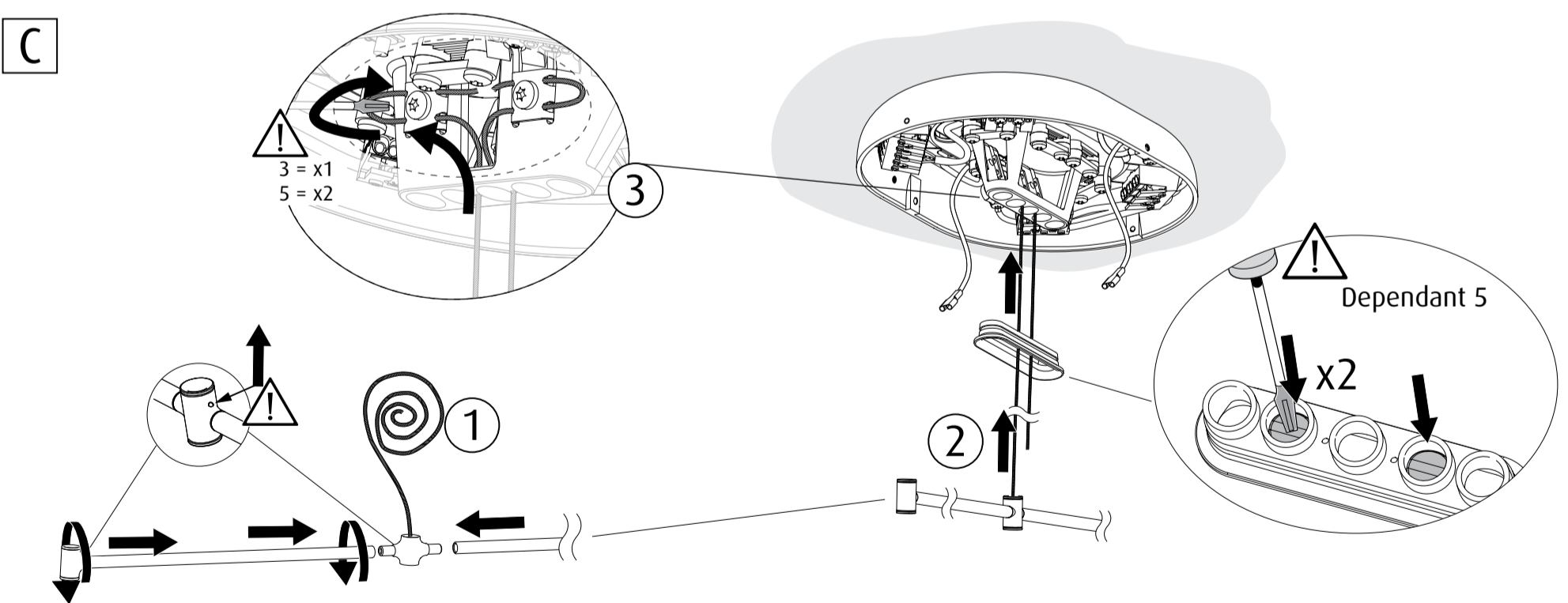

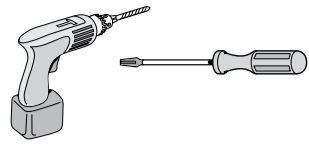
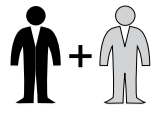

D

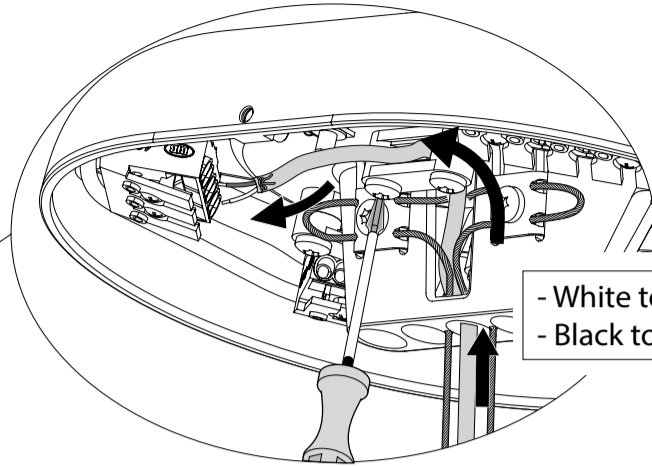
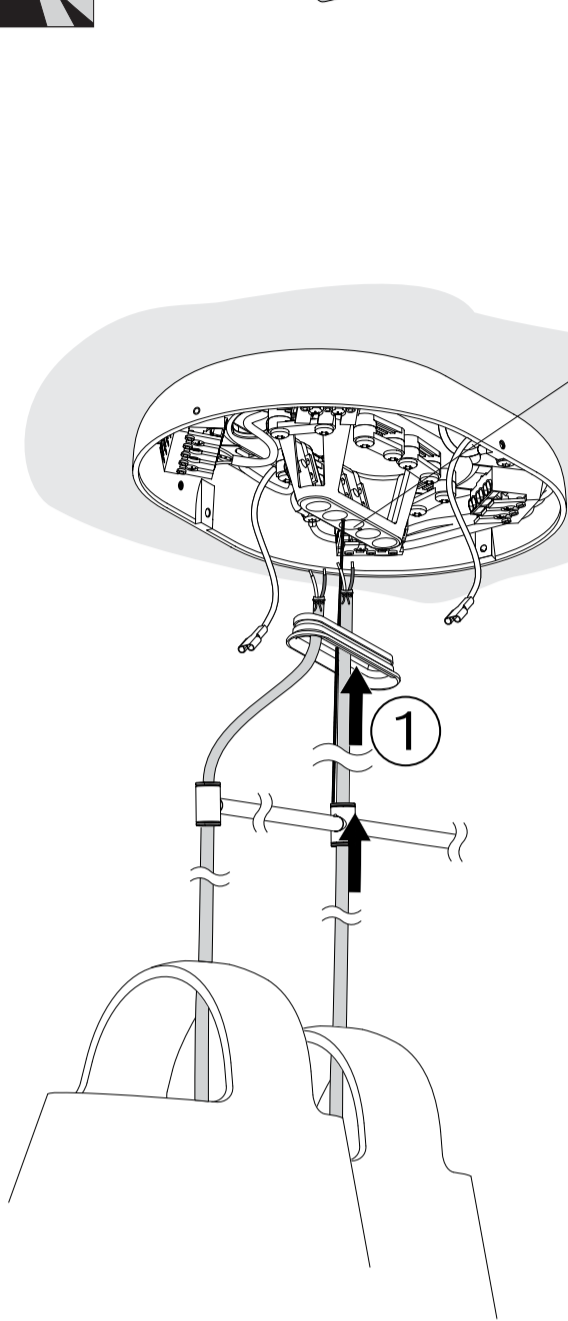

- White to neutral
 - Black to line

3 = x3
 5 = x5



E

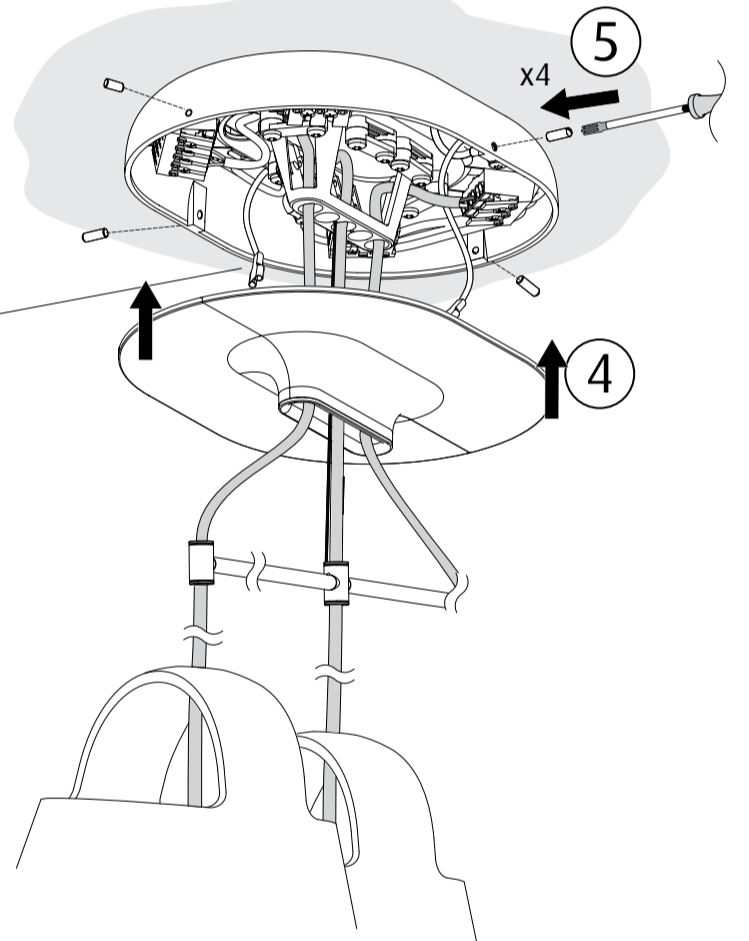
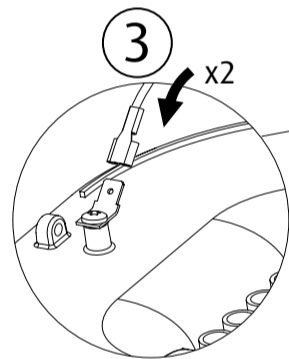
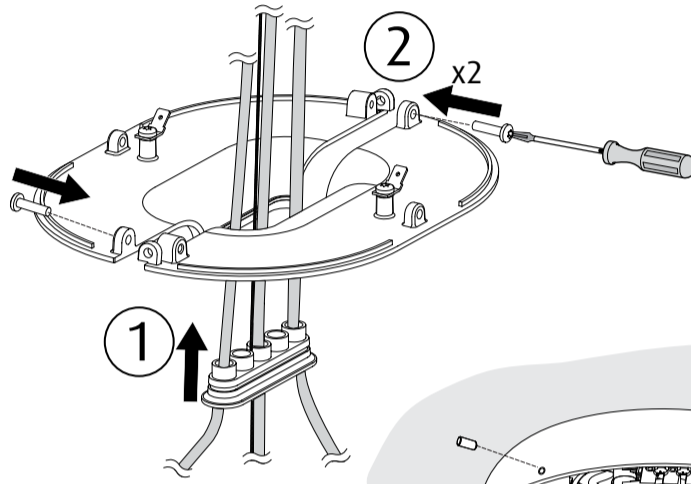

F

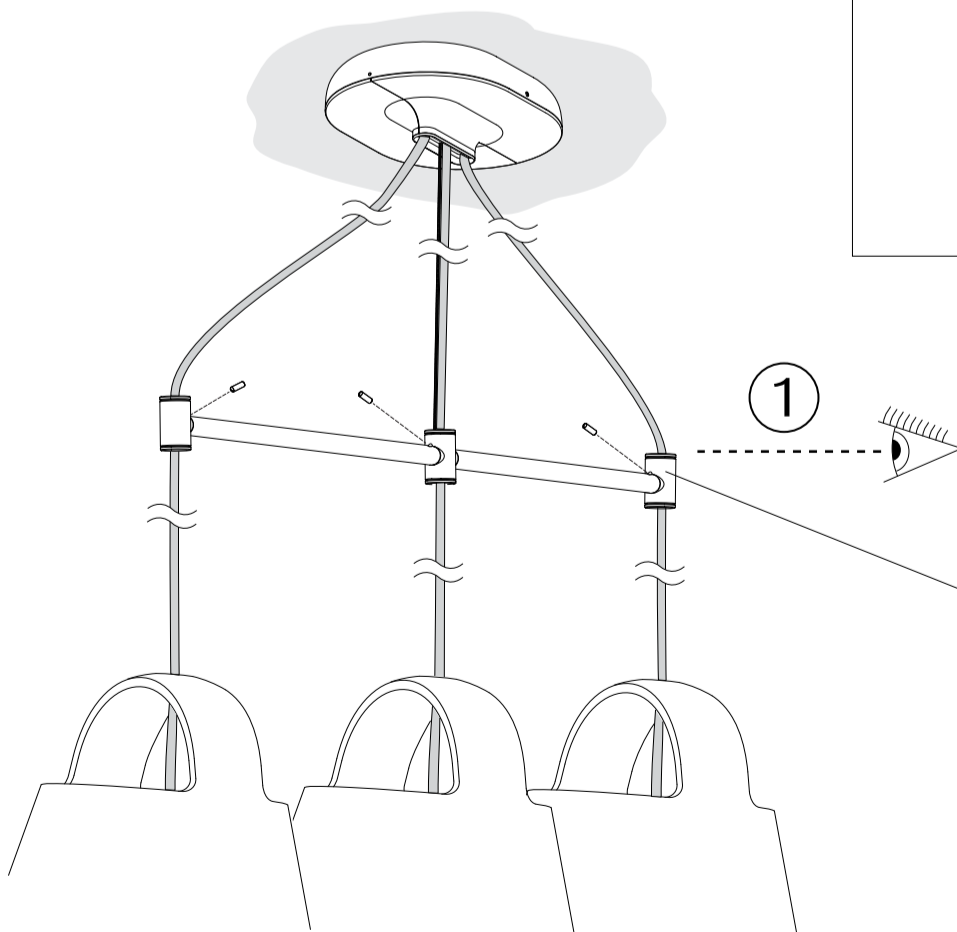

3 = x3
 5 = x5

