

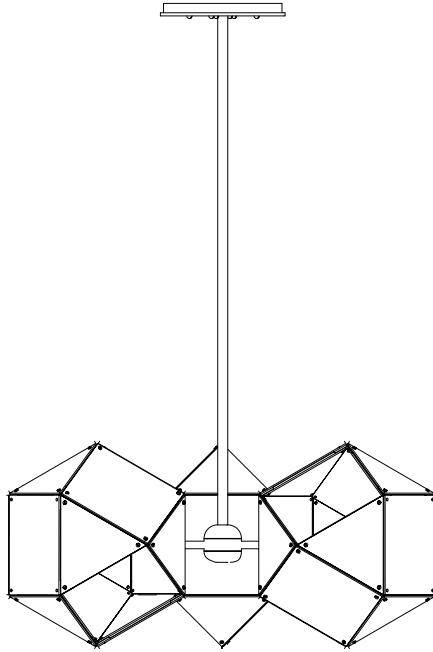

FILE#: E356487



The **WELLES** Spoke Pendant Installation Guide

- Suspended mounted only.
- Certified electrician recommended for electrical installation.
- Terminal Block not included. Installation may require advice from a qualified person.
- Junction box or structural blocking rated minimum to support 50 lbs required.
- For all LED fixtures, use only with class 2 power unit.
- The light source contained in this luminaire shall only be replaced by the manufacturer or his service agent or a similar qualified person.

***IMPORTANT: Please provide email confirmation that your order and its related components have been received in their entirety and in good condition. Failure to do so within 7 days of delivery will waive all product warranties.**

GABRIEL SCOTT

EST. 2012



Provided Supplies

- Welles Spoke Fixture
- Stem
- Canopy + Screws
- T-Bar
- LED driver
- Spare LED chip

Required Tools:

- Screwdriver
- 4x 2-pole Wiring Terminals, screw or screwless, 12-18AWG (1.0-2.5mm²), rated for 600V, 15A - EX: WAGO 222-412
- Requires LED driver; Input: Local Line Voltage, Output 12Vdc SELV, 5A, Max 60 Watt, Class 2 LED Driver.

STEP
1

Shut-down associated electrical breaker and wire LED driver to power source and secure driver to blocking or in a remote area. Then secure the T-bar to the junction box.

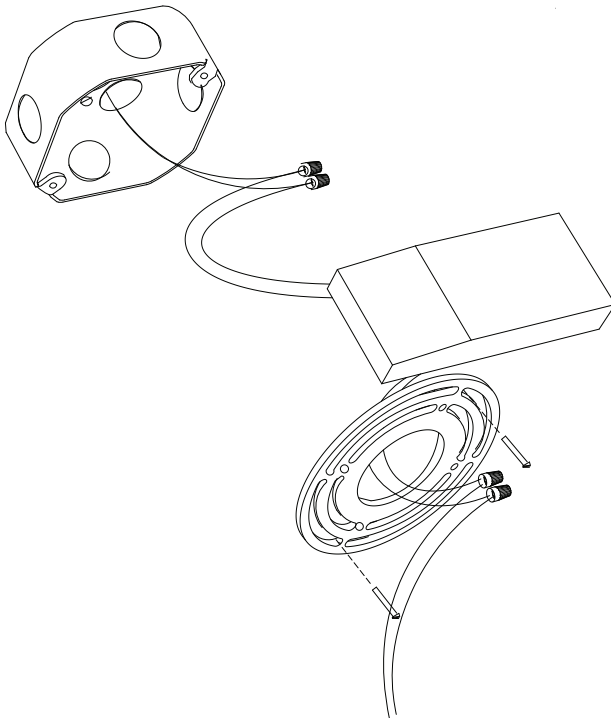

STEP
6

Pass the wires through the stem and thread it on to the light fixture. Finally thread the stem through the canopy and lock it in place with the nut provided.

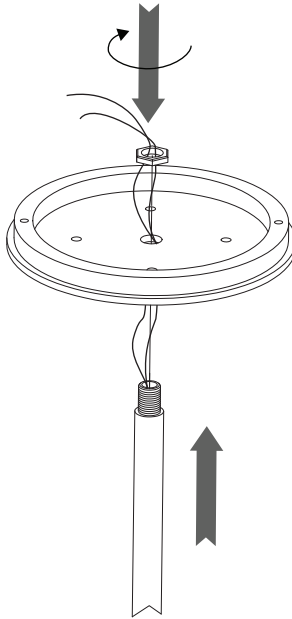

STEP
6

Using terminals, wire in light fixture to the LED driver.

Using the provided screws, attach the Briollette fixture's canopy to the T-bar and secure firmly.

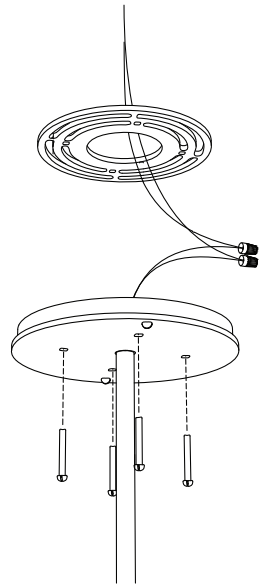

Note:

On Gabriel-Scott fixtures the black wire(+) is positive and the whitewire(-) is neutral.



e: info@GabrielScott.com

t: (646) 783-3770