

CIRCUS acoustic panel P500

ver. 20200404_Rev_0

year: 2015
code: 1733803N0xxxx
type: acoustic device
destination: indoor



Technical drawing

Size

ref. image mm - inch

HANGING installation

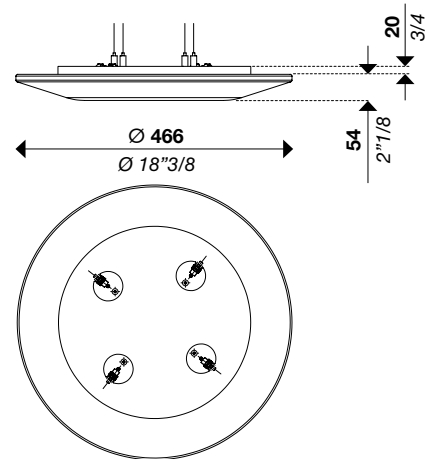

CEILING installation

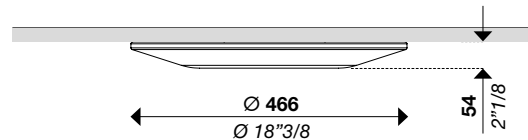

Product description

Honeycomb polycarbonate acoustic panel ø500 mm with a removable upholstery in white, beige or black 100% polyester 3D fabric (more colors on request).

CIRCUS acoustic panel combinable with *CIRCUS hanging lamp*.

Material

Realized with polyester staple fibre, no toxic and non-polluting. It allows an high and long-lasting resistance to microbiological damages (non-putrescible material) and UV rays.

Composition	polyester staple fibre
Colour	White
Surface weight	2000 g/m ²
Thickness	40 mm
Density	50 Kg/m ³
Working temperature	-40 ÷ +95
Resistance to	diffusion of water vapour
	molds
	parassites
	ozone
	bad weather
	UV

Hanging cables

Stainless steel cables standard length (custom available) 2000 mm / 78"03/4

Warranty

Duration 2 years

The values above should not be considered as absolutes but aimed to lead material's choice in function of the final use.

CIRCUS acoustic panel P500

ver. 20200404_Rev_0

year: **2015**
 code: **1733803N0xxxx**
 type: **acoustic device**
 destination: **indoor**

Available versions

Standard finish

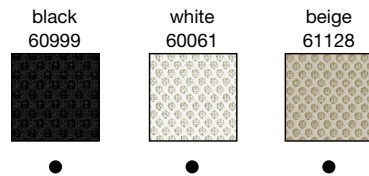

Finish on request

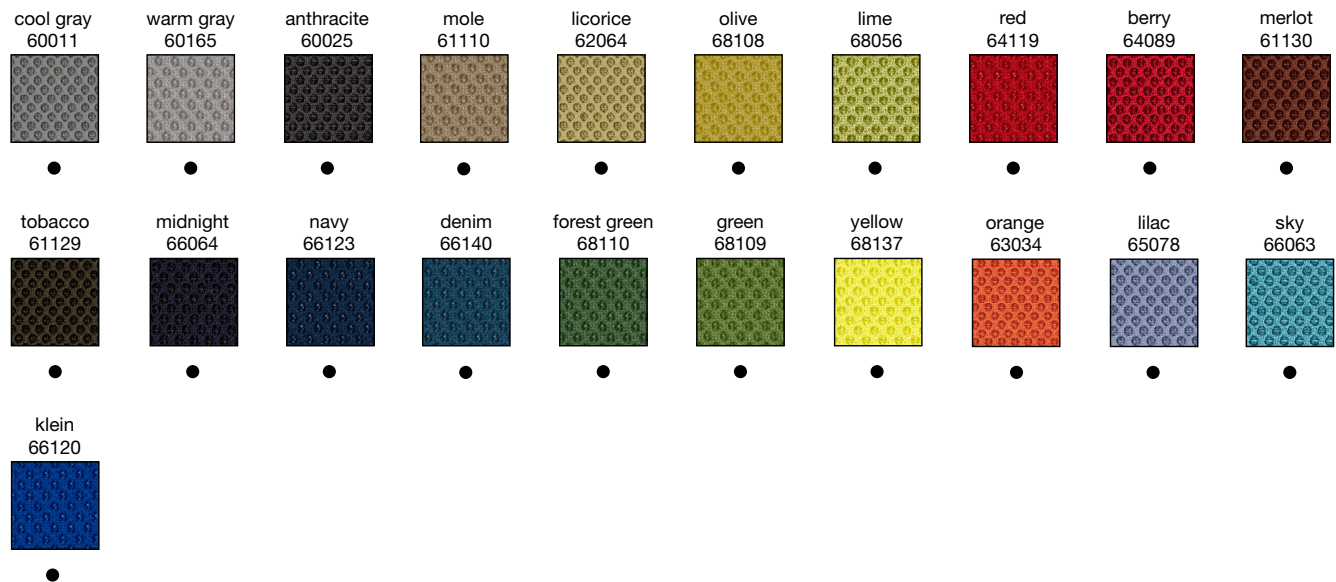

CIRCUS acoustic panel P500

ver. 20200404_Rev_0

year: 2015
 code: 1733803N0xxxx
 type: acoustic device
 destination: indoor

HANGING installation

Acoustic class: C
 $\alpha_w = 0,55$
 Distance from the ceiling: 1m

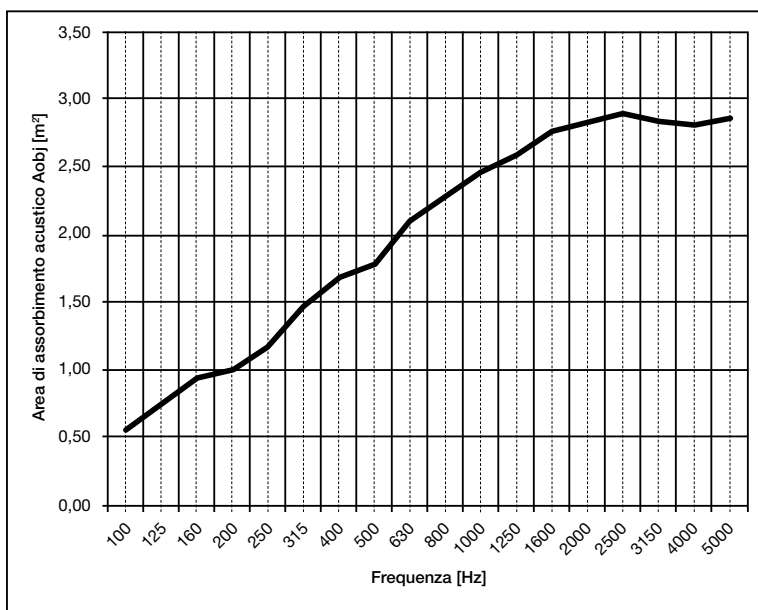

CEILING installation

Acoustic class: A
 $\alpha_w = 1$

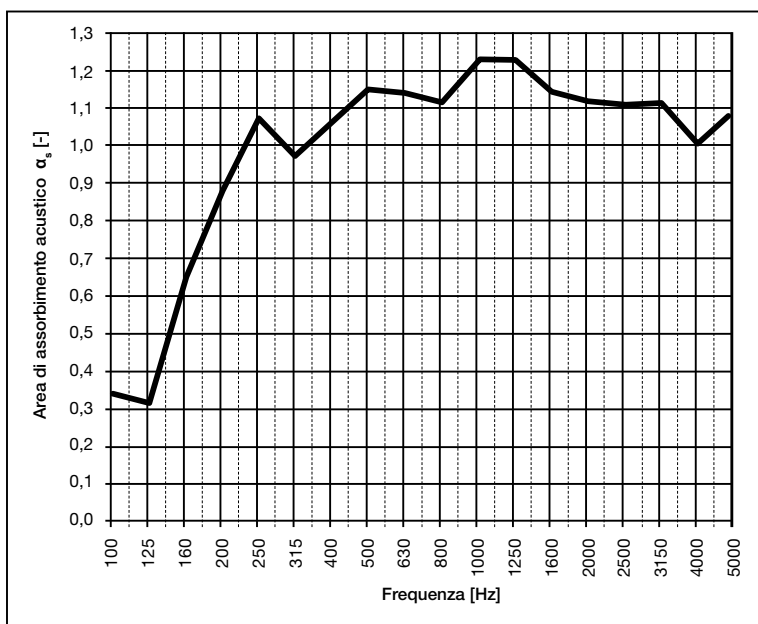

CIRCUS acoustic panel P1000

ver. 20200404_Rev_0

year: 2015
code: 1733801N0xxxx
type: acoustic device
destination: indoor

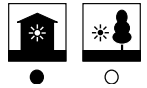

Technical drawing

Size ref. image mm - inch

HANGING installation

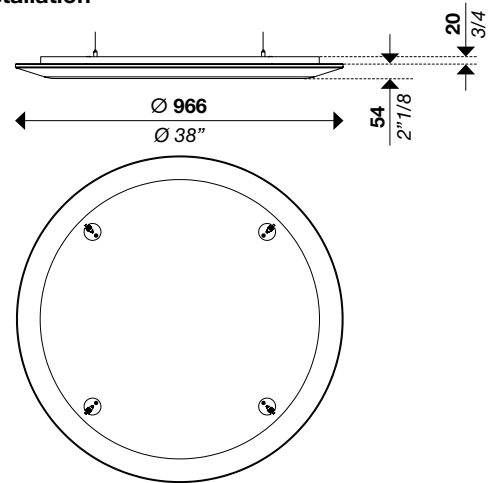

Product description

Honeycomb polycarbonate acoustic panel ø1000 mm with a removable upholstery in white, beige or black 100% polyester 3D fabric (more colors on request).

CIRCUS acoustic panel combinable with *CIRCUS hanging lamp*.

Material

Realized with polyester staple fibre, no toxic and non-polluting. It allows an high and long-lasting resistance to microbiological damages (non-putrescible material) and UV rays.

Composition	polyester staple fibre
Colour	White
Surface weight	2000 g/m ²
Thickness	40 mm
Density	50 Kg/m ³
Working temperature	-40 ÷ +95
Resistance to	diffusion of water vapour
	molds
	parassites
	ozone
	bad weather
	UV

CEILING installation

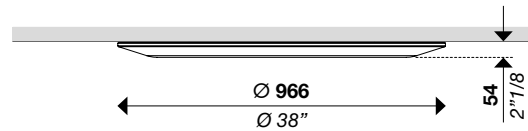

Hanging cables

Stainless steel cables standard length (custom available) 2000 mm / 78"03/4

Warranty

Duration 2 years

The values above should not be considered as absolutes but aimed to lead material's choice in function of the final use.

CIRCUS acoustic panel P1000

ver. 20200404_Rev_0

year: **2015**
 code: **1733801N0xxxx**
 type: **acoustic device**
 destination: **indoor**

Available versions

Standard finish

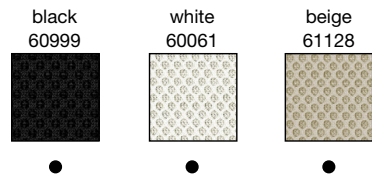

Finish on request

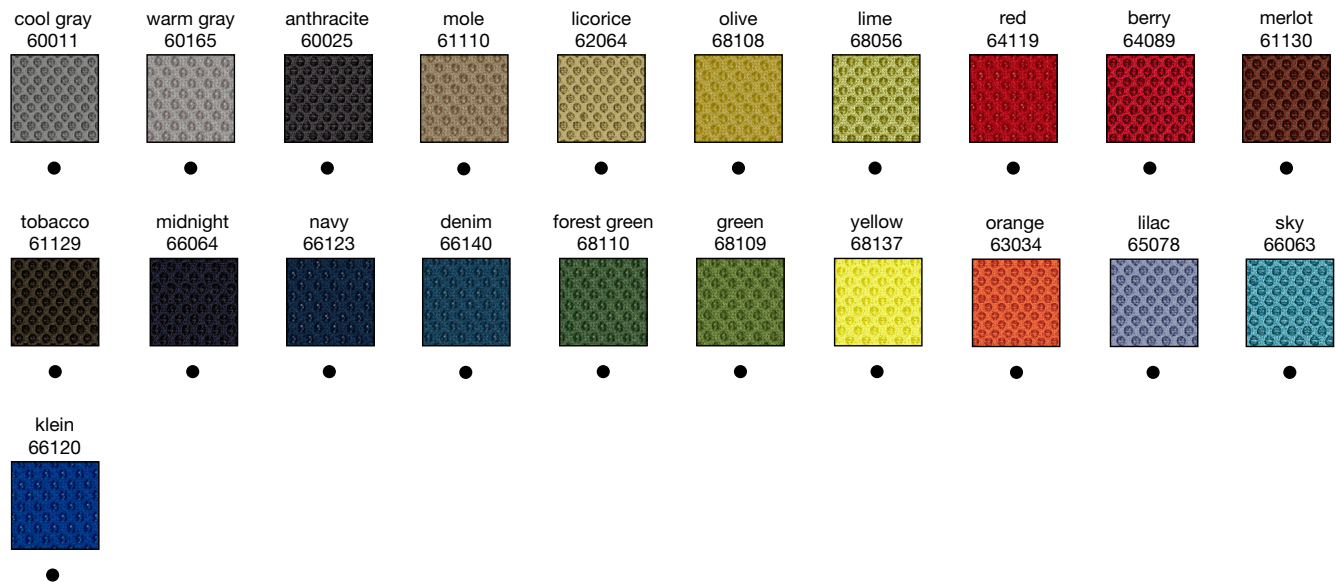

CIRCUS acoustic panel P1000

ver. 20200404_Rev_0

year: 2015
 code: 1733801N0xxxx
 type: acoustic device
 destination: indoor

HANGING installation

Acoustic class: C
 $\alpha_w = 0,55$
 Distance from the ceiling: 1m

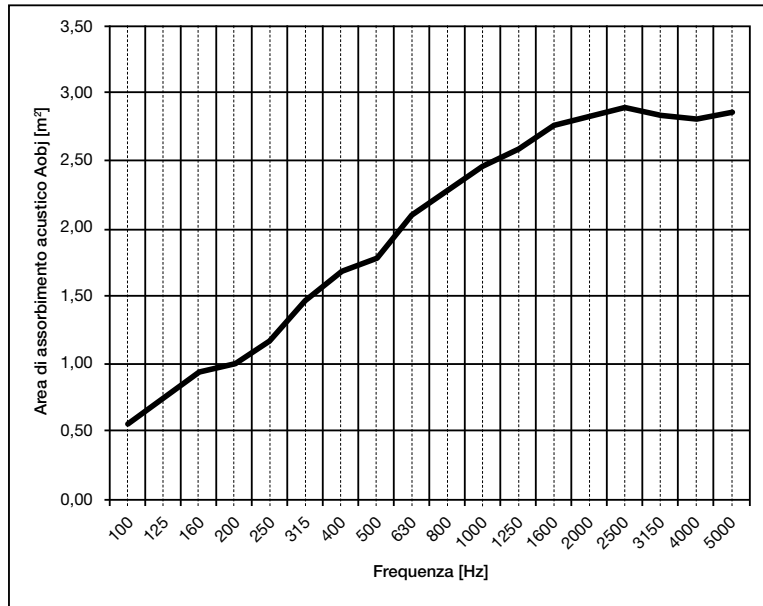

CEILING installation

Acoustic class: A
 $\alpha_w = 1$

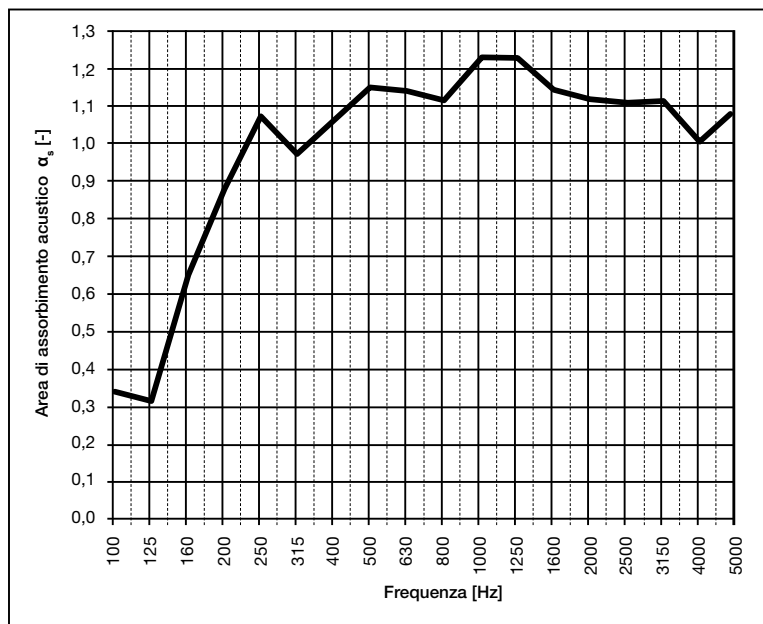

CIRCUS acoustic panel P1500

ver. 20200404_Rev_0

year: 2015
code: 1733802N0xxxx
type: acoustic device
destination: indoor



Technical drawing
Size ref. image mm - inch

HANGING installation

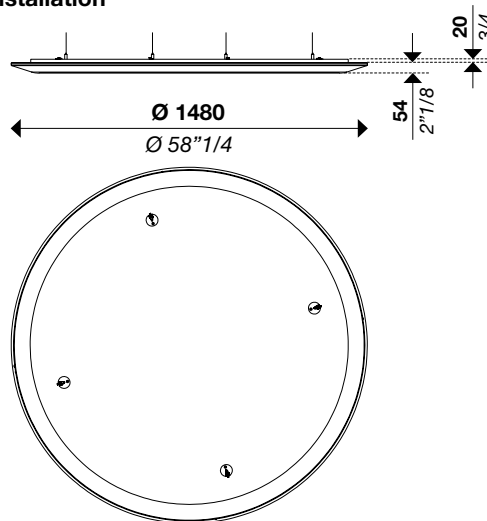

CEILING installation

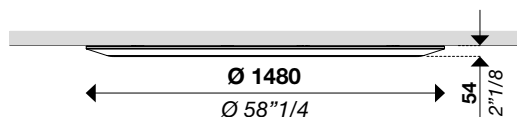

Product description

Honeycomb polycarbonate acoustic panel ø1500 mm with a removable upholstery in white, beige or black 100% polyester 3D fabric (more colors on request).

CIRCUS acoustic panel combinable with *CIRCUS hanging lamp*.

Material

Realized with polyester staple fibre, no toxic and non-polluting. It allows an high and long-lasting resistance to microbiological damages (non-putrescible material) and UV rays.

Composition	polyester staple fibre
Colour	White
Surface weight	2000 g/m ²
Thickness	40 mm
Density	50 Kg/m ³
Working temperature	-40 ÷ +95
Resistance to	diffusion of water vapour
	molds
	parassites
	ozone
	bad weather
	UV

Hanging cables

Stainless steel cables standard length (custom available) 2000 mm / 78"03/4

Warranty

Duration 2 years

The values above should not be considered as absolutes but aimed to lead material's choice in function of the final use.

CIRCUS acoustic panel P1500

ver. 20200404_Rev_0

year: 2015
 code: 1733802N0xxxx
 type: acoustic device
 destination: indoor

Available versions

Standard finish

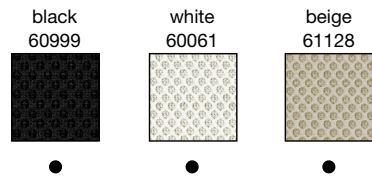

Finish on request

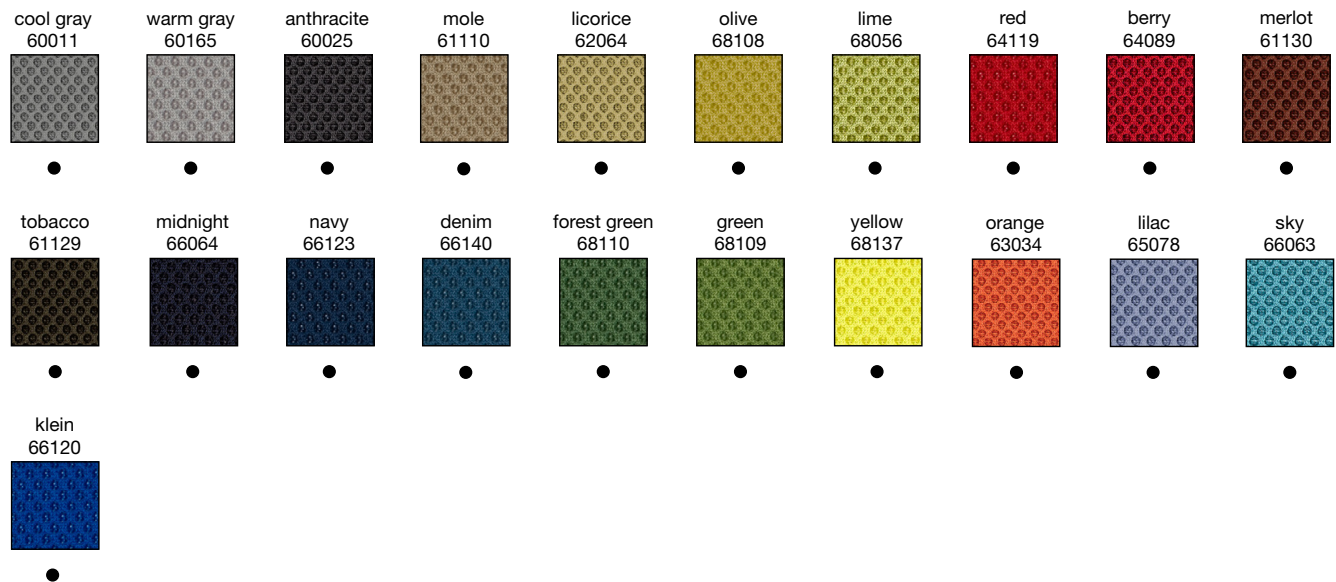

CIRCUS acoustic panel P1500

ver. 20200404_Rev_0

year: 2015
 code: 1733802N0xxxx
 type: acoustic device
 destination: indoor

HANGING installation

Acoustic class: C
 $\alpha_w = 0,55$
 Distance from the ceiling: 1m

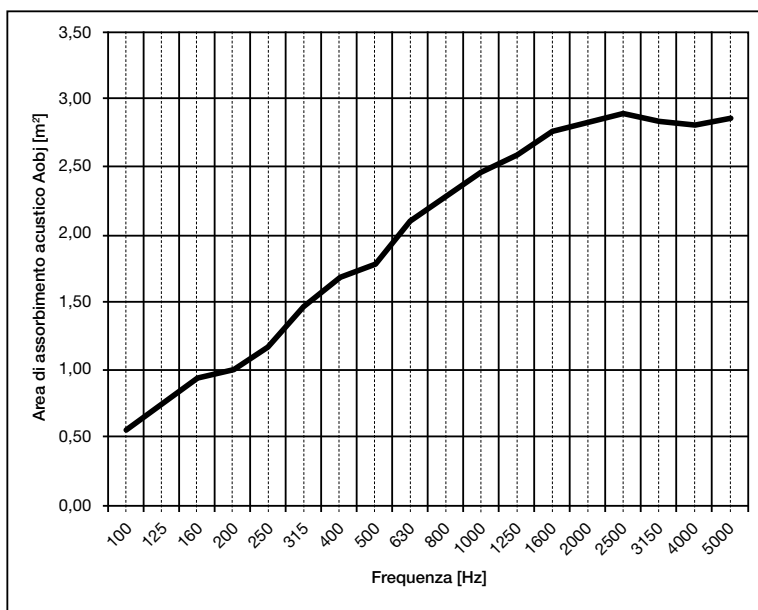

CEILING installation

Acoustic class: A
 $\alpha_w = 1$

