

Installation Instructions for **Twiggy Hinged 12V AC, Direct Lens with 4" Square Canopy or 1" Rectangular Canopy**

IMPORTANT INFORMATION

- This instruction shows a typical installation.
- This product must be installed by a qualified electrician.
- The 1RE version mounts to the provided C-1RE-JBOX. The 4SQ version mounts to standard electrical box with plaster ring or octagon box.
- **Before beginning any electrical work, ensure that the power to the installation is turned OFF!**

SAVE THESE INSTRUCTIONS!

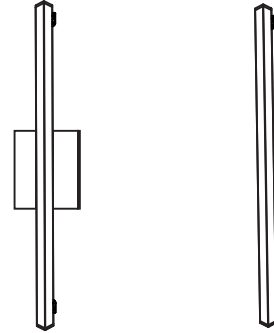

Section One: Steps for TWH12-D1-1RE

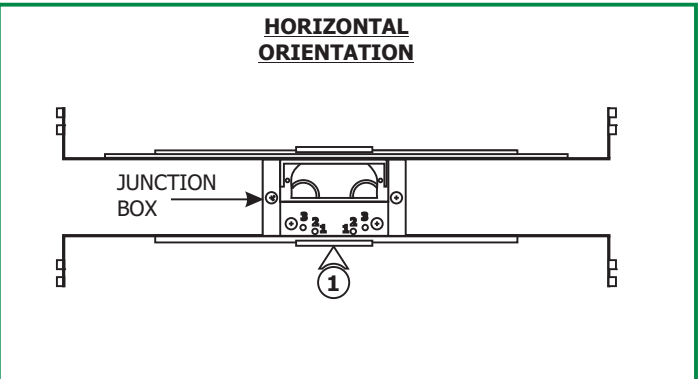
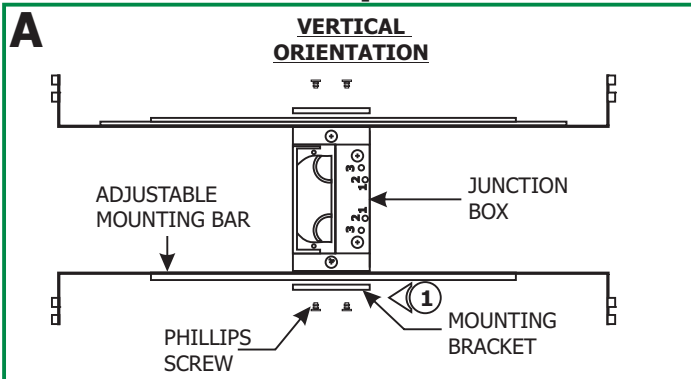

- 1:** Mount each adjustable mounting bar to one side of the junction box (mounts to any side of the housing depending on the orientation of the channel) and secure them with the mounting brackets and two Phillips screws provided.

NOTE: The adjustable mounting bars mount to studs that are spaced 13" to 24" apart.

NOTE: Ensure the opening of the junction box is aligned with the center of the desired fixture location. If necessary, adjust the junction box location by loosening the screws and sliding the junction box to the proper location. Tighten the Phillips screws after adjusting.

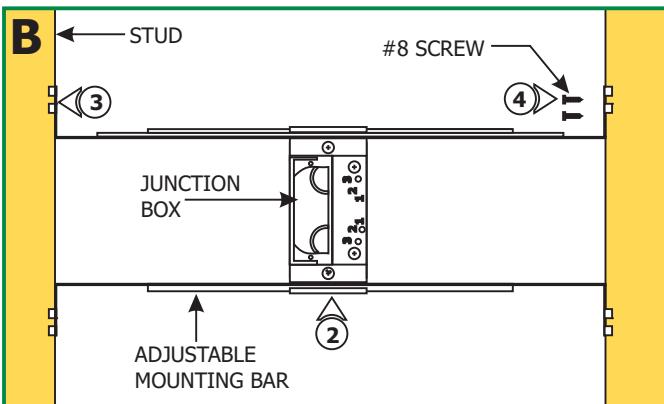

NOTE: The adjustable mounting bars mount to studs that are spaced 13" to 24" apart.

- 2:** Select the location between the two studs for the junction box to be mounted.
- 3:** Place the adjustable mounting bars between the studs.
- 4:** Make sure the lips on the adjustable mounting bars are against the studs. Secure the adjustable bars to the studs with the eight #8 screws.

- 5:** Remove a knockout to install the power line conduit.

- 6:** Ensuring power to the junction box is off, install the conduit and run the 120V power wires.

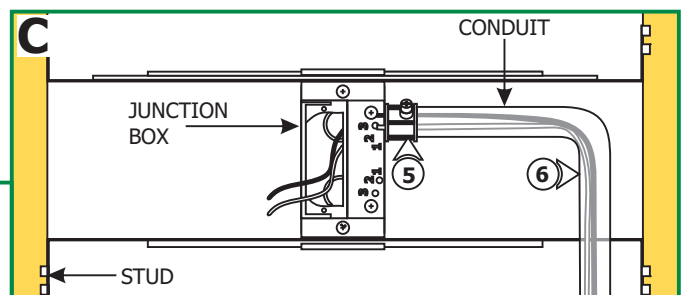

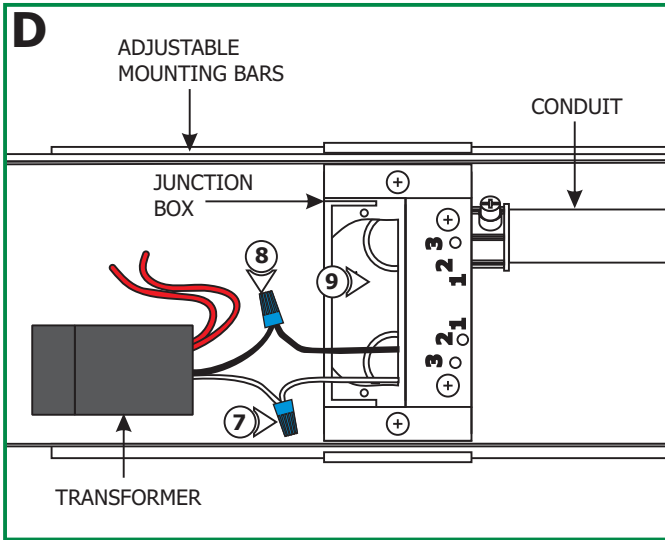

NOTE: If necessary junction box opening can be adjusted, in three positions from position 1 at 0.85", 2 at 0.95" or 3 at 1.05". Simply loosen screws and tighten to the corresponding position labeled on junction box.

- 7: Connect the white transformer wire to the neutral power wire with a wire nut.
- 8: Connect the black transformer wire to the hot power wire with a wire nut.
- 9: Place the transformer and transformer wires inside the junction box.

- 10: Mark a rectangle shape on drywall where the junction box opening will be located depending on selected position.
- 11: Cut out the marked rectangle opening, using a "Dremel Multi-Max" with the "wood & drywall" cutting bit.
- 12: Follow steps in Section Three to complete installation.

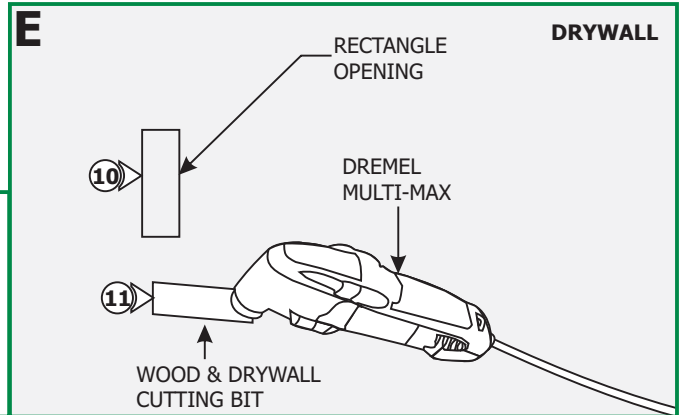

Section Two: Steps for TWH12-D1-4SQ

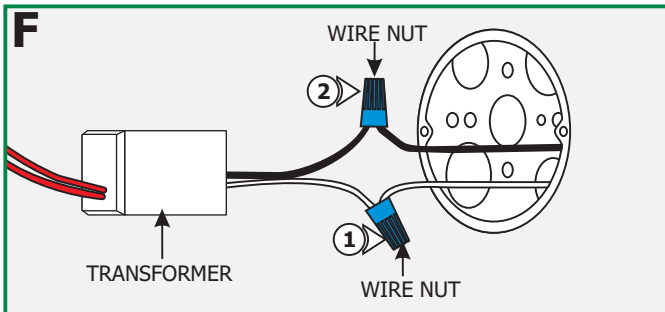

NOTE: Low-voltage power wires should be present in the junction box before completing the steps in this section.

- 1: Connect the white power supply wire to the neutral power wire with a wire nut.
- 2: Connect the black power supply wire to the hot power wire with a wire nut.
- 3: Place the power supply and wires inside the electrical box.
- 4: Follow steps in Section Three to complete installation.

Section Three: Install Fixture

NOTE: Twiggly Hinge w/rectangular junction box shown for illustration purposes.

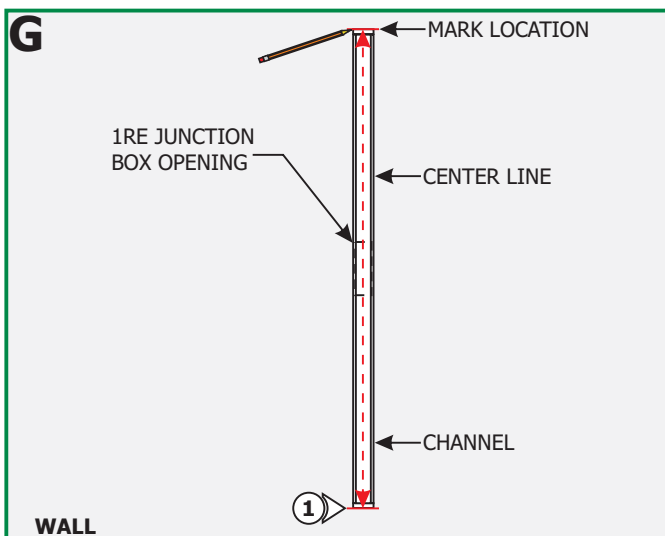

NOTE: It is recommended more than one person to assist in this installation.

NOTE: Fixture can be mounted in a horizontal or vertical position.

NOTE: Channel rotates in only one direction, so orientation must be determined before installing.

NOTE: The junction box does not need to be in middle of the channel (could be mounted from any end) but needs to be aligned in the center of the channel.

- 1: Center the channel to the junction box opening. Make markings to each end of the channel and also make a center line from end to end.

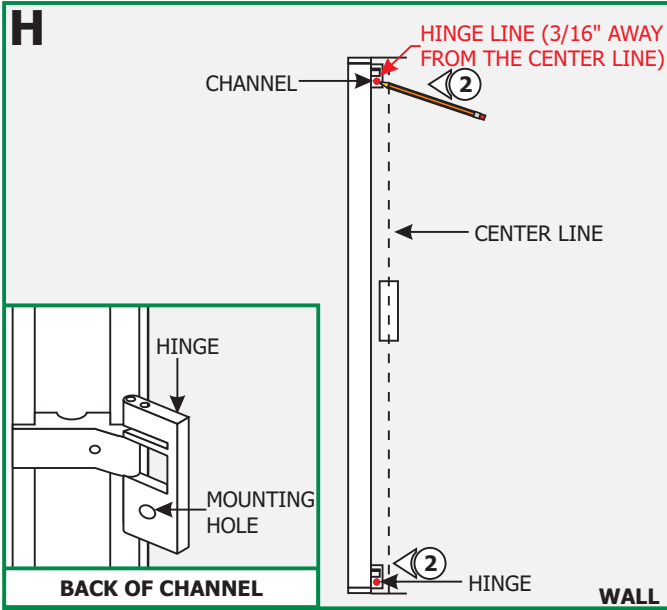

2: Unfold the channel hinges. Align the channel between the marked lines and mark the hinge holes 3/16" away from the center line.

NOTE: If the junction box is located at one end of the channel, then loosen the #4-40 set screw with the 0.05 Allen wrench on one of the back cover moving the opening hole to one end. Pull the wire out of that end & retighten the #4-40 set screw with the 0.05 Allen wrench.

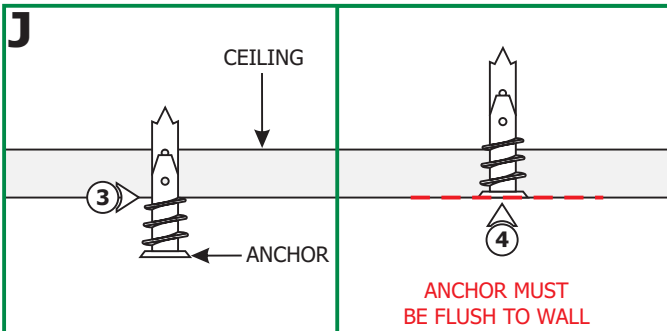
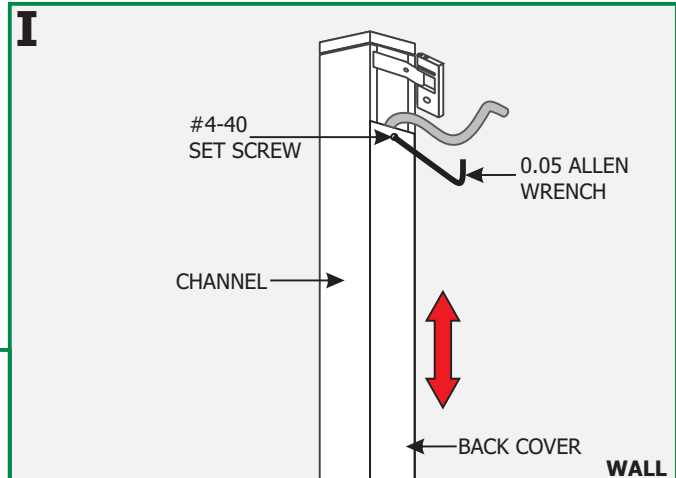

3: Tap the anchors onto the marked points up to the threaded portion with a hammer.

4: Screw in the threaded portion of the anchors with a Phillips screwdriver.

5: Line up the hinge to the anchors and secure it by tightening the #8 screws to each hinge.

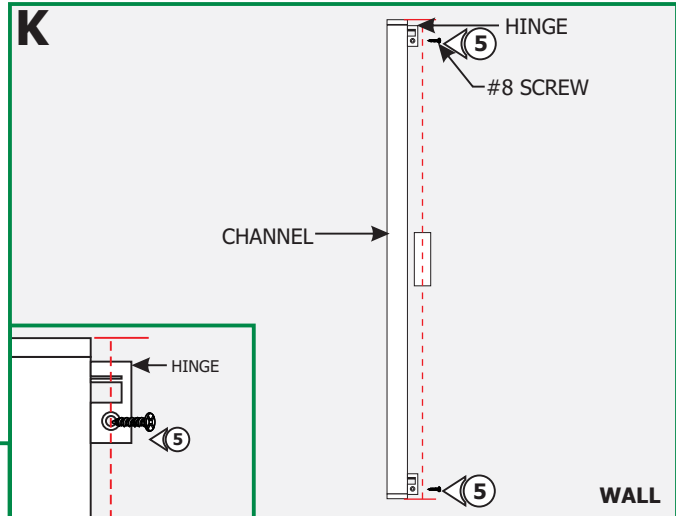

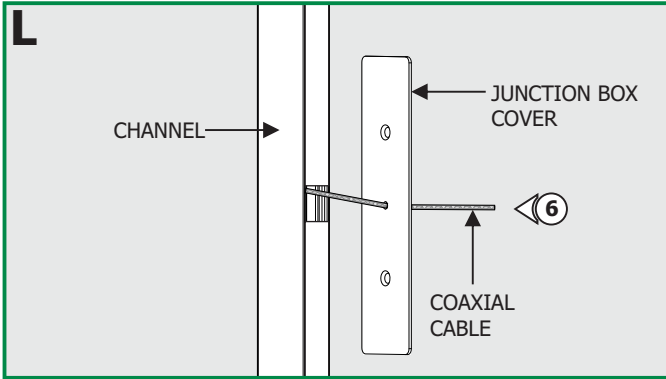

6: Pull the coaxial cable through center hole of junction box cover.

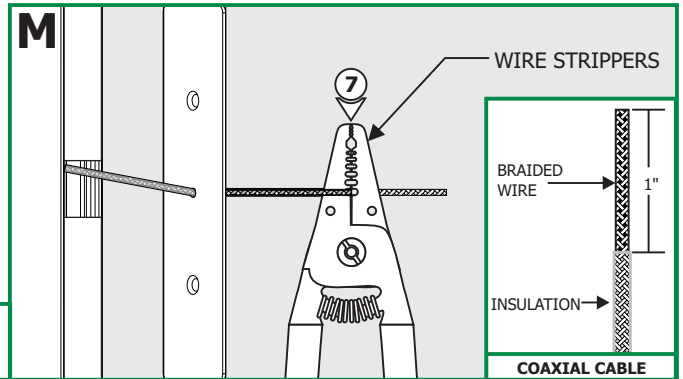

7: Using the 16 AWG hole of a pair of wire strippers, remove 1" of outer plastic insulation from the coaxial cable.

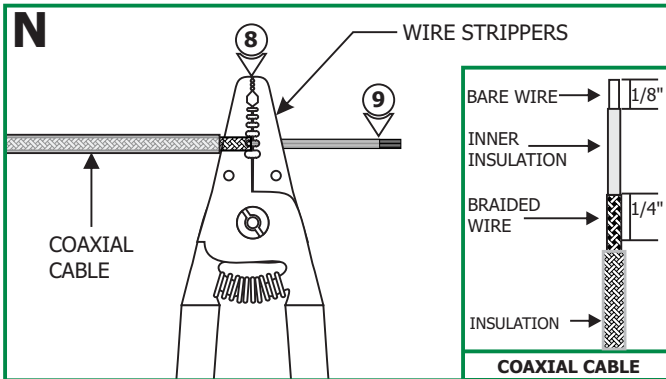

8: Using the 18 AWG hole of the wire strippers, remove braided wire leaving 1/4" from the outer plastic insulation.

9: Using the 20 AWG hole of the wire strippers, remove 1/8" of inner plastic insulation from the end of the coaxial cable.

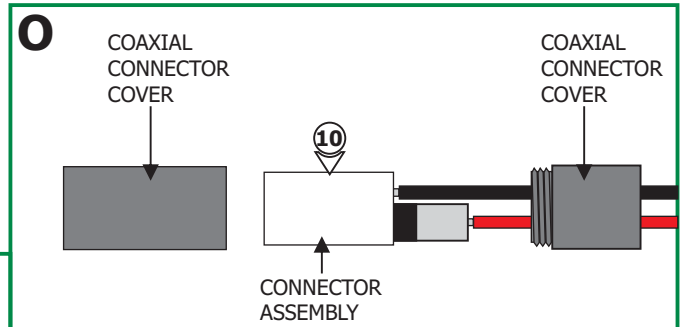

10: Unscrew the coaxial connector covers and remove from the connector assembly.

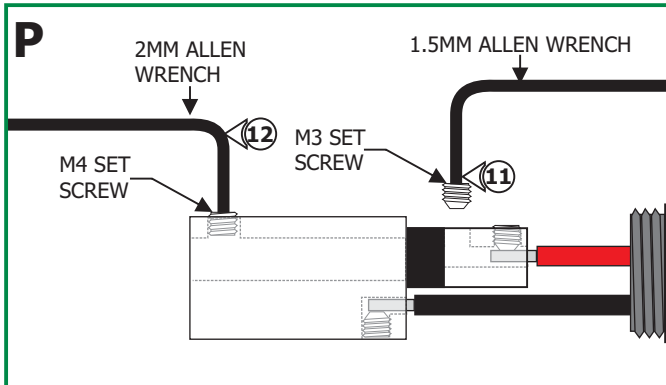

11: Using the provided 1.5mm Allen Wrench, remove the M3 set screw from the coaxial connector assembly.

12: Using the provided 2mm Allen wrench to loosen (do not remove) the M4 set screw.

13: Slide the connector cover over the coaxial cable.

14: Place the ferrule over the braided wire of the coaxial cable.

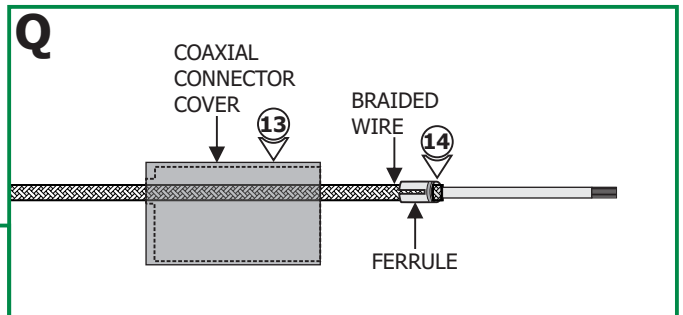

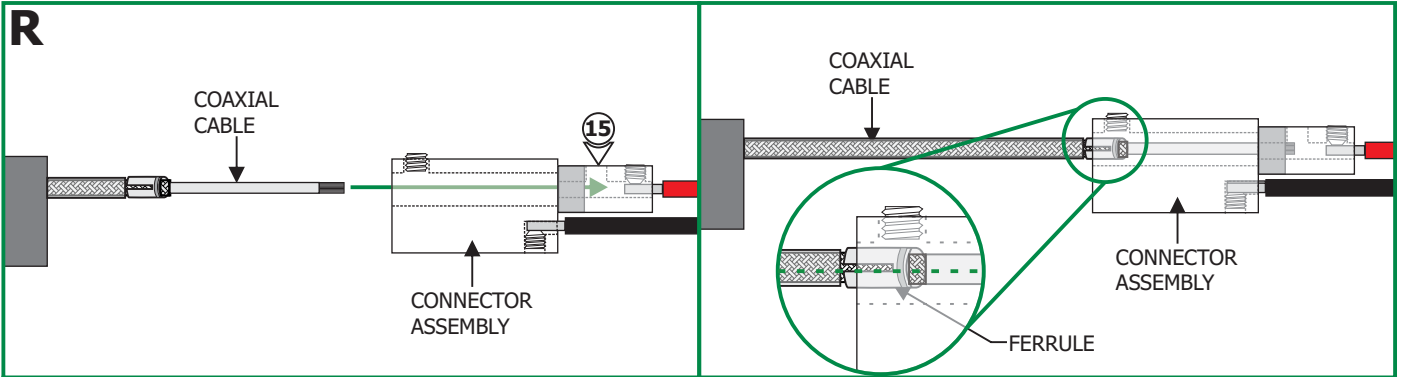

15: Insert the coaxial cable into the coaxial connector until the wires of the center conductor are visible through the M3 set screw hole.

NOTE: Ensure that the split in the ferrule is aligned 90° from the M4 set screw (see inset).

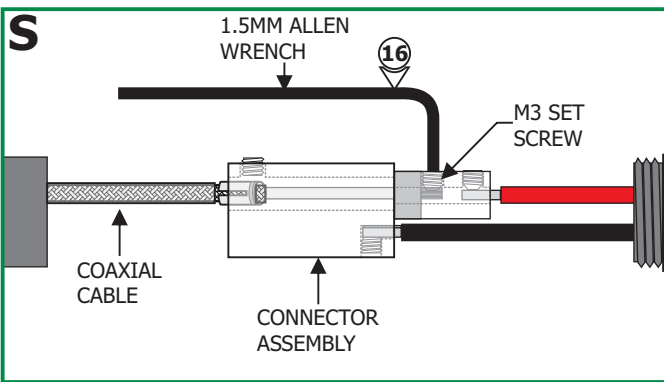

16: Use the provided 1.5mm Allen wrench to replace and securely tighten the M3 set screw.

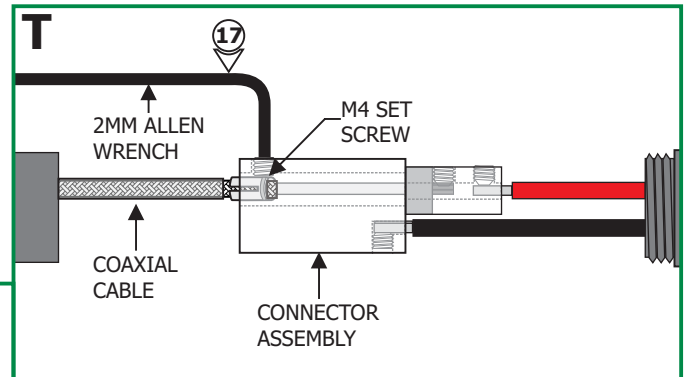

17: Use the provided 2mm Allen wrench to securely tighten the M4 set screw until it squeezes the wire ferrule tightly to the coaxial cable.

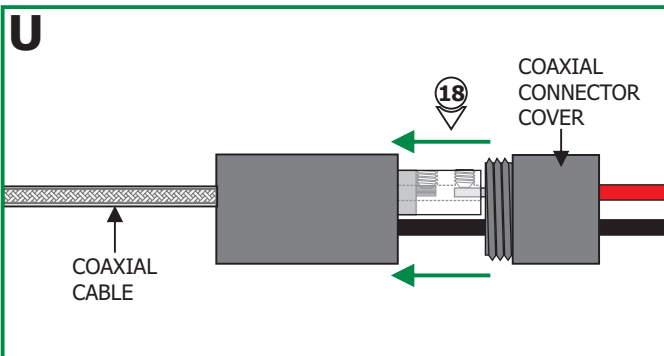

18: Replace the coaxial connector cover and tighten into place.

19: Connect the red wire from the coaxial connector to one of the LED driver wires using a wire nut.

20: Connect the black wire to the remaining LED driver wire using a wire nut.

21: Place all connections into the junction box.

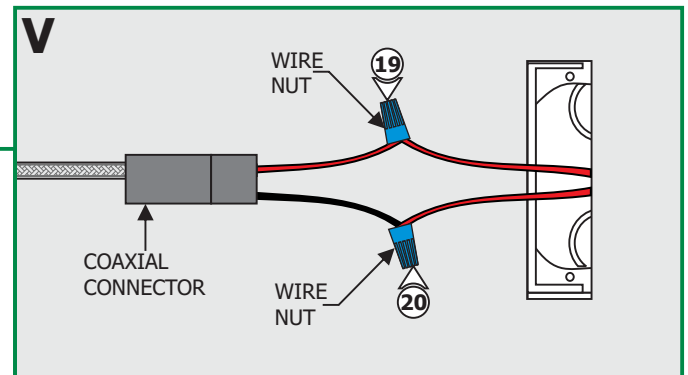

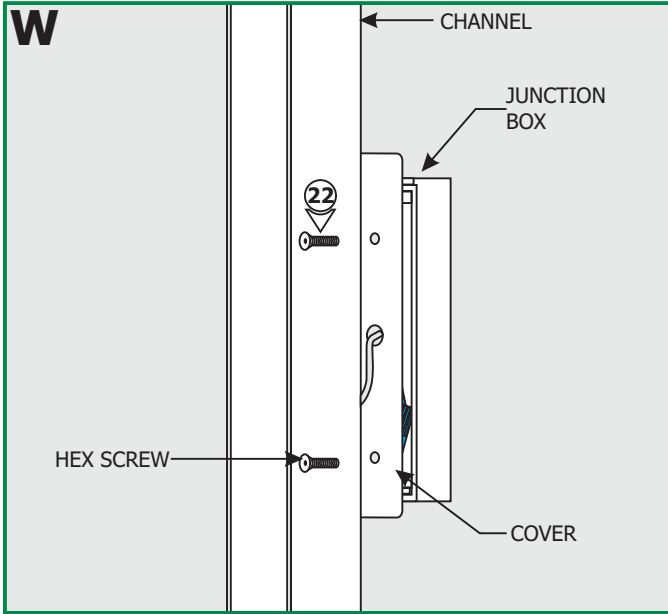

22: Attach the junction box cover to the junction box with the provided hex screw.

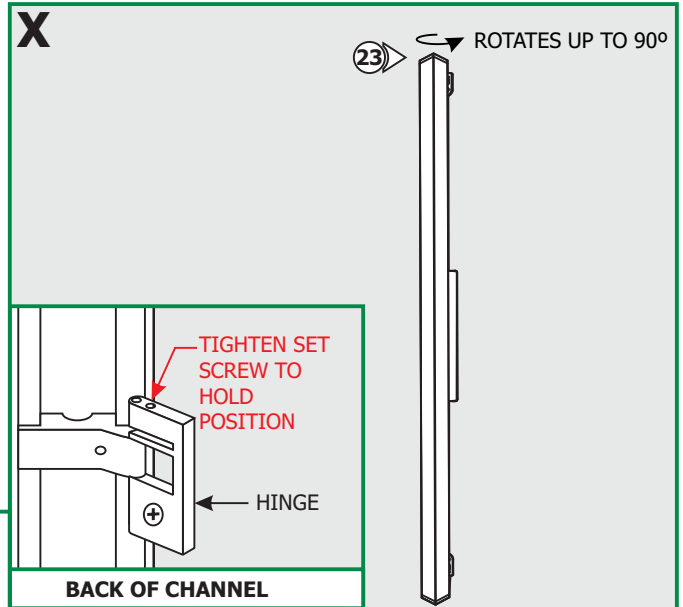

23: If necessary channel can be rotated up to 90° degrees, and to hold the position, tighten the M2 set screw to each the hinge with a 0.9mm Allen wrench.

GENERAL WIRING DIAGRAM

