



1718 W. Fullerton Chicago, IL 60614  
 Ph: 773.770.1195 • Fax: 773.935.5613  
 www.PureEdgeLighting.com • info@PureEdgeLighting.com  
 © 2016 PureEdge Lighting. All Rights Reserved.

## Installation Instructions for TruLine .5A L-Picture Frame Power Channel Connector

### IMPORTANT INFORMATION

- This instruction must be used concurrently with other TruLine .5A BIY installation instructions.
- This product is wall or ceiling mount.
- This instruction shows a typical installation.

**SAVE THESE INSTRUCTIONS!**

### Section One: Install the Junction Box

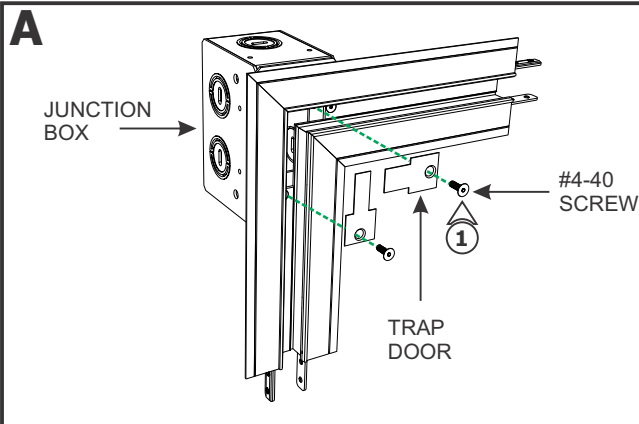

**1:** Remove the #4-40 screws from the junction box to remove the trap door from the assembly using a 1/16" Allen wrench.

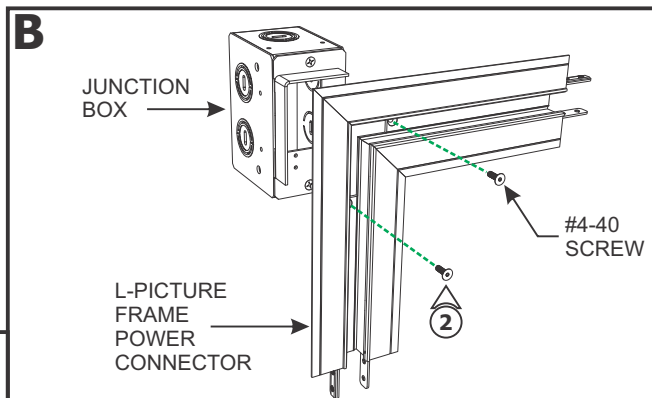

**2:** Remove the #4-40 screws to remove the L-Picture Frame Power Connector from the junction box using a 1/16" Allen wrench.

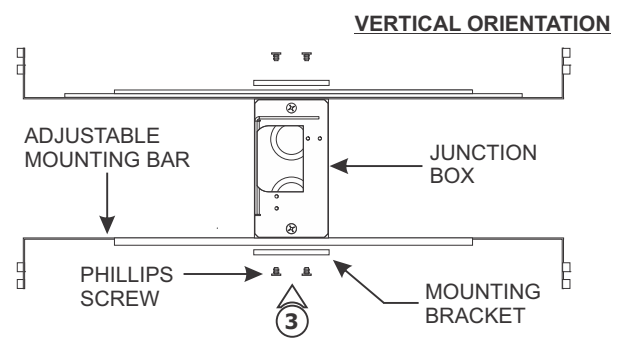
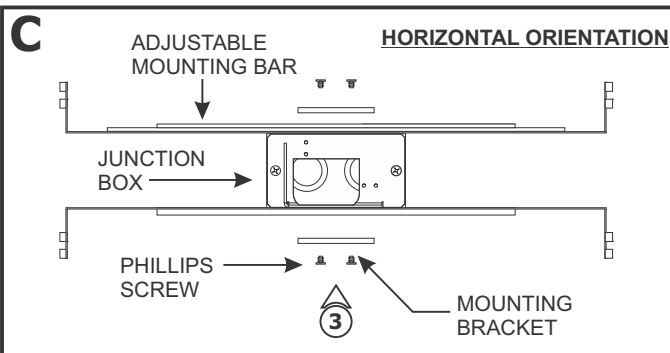

**3:** Mount each adjustable mounting bar to one side of the junction box and secure them with the mounting brackets and two Phillips screws provided.

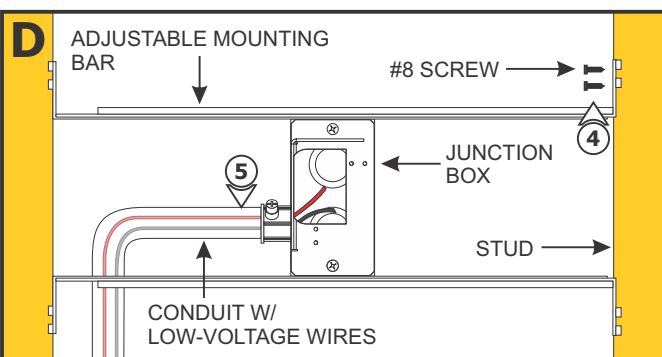

**NOTE:** The adjustable mounting bars mount to studs that are spaced 13" to 24" apart.

**4:** Place the lips on the adjustable mounting bars against the studs. Secure the adjustable bars to the studs with the eight #8 screws.

**5:** Install conduit(s) (if required by local electrical code) and run low voltage wires to the junction box.

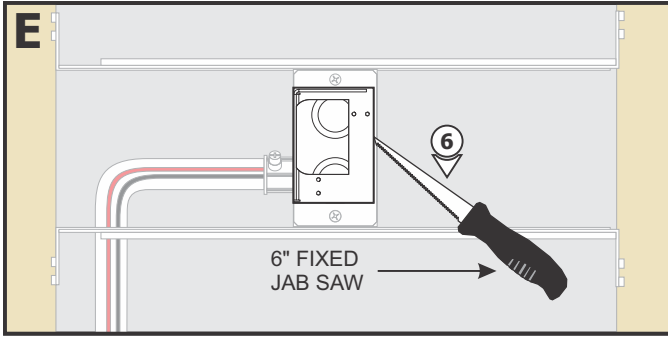

**6:** Cut a section of drywall using a 6" fixed jab saw or other appropriate tool to expose the mounting plate area.

**7:** If using the Snap & Light connector (LC-SLC) with standard Soft Strip, cut the end of the power cord and discard the unused connector. Strip the ends of the wires.

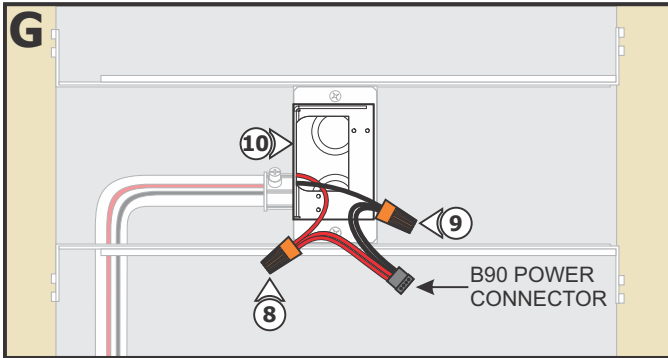
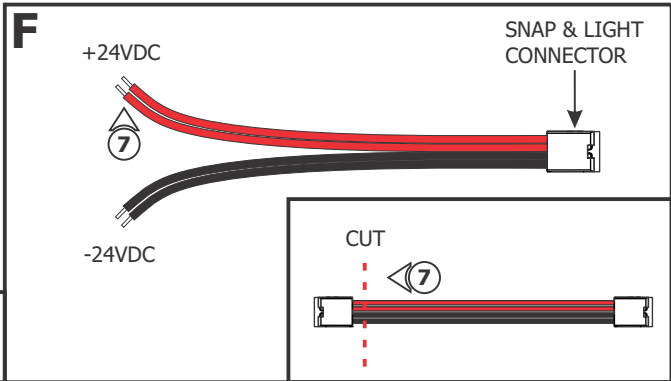

**NOTE:** Remote power supply wires must be present in junction box. Refer to instructions provided with power supply.

**8:** Connect the red low voltage wire of the power supply to the red wires of either the B90 connector or Snap & Light connector with a wire nut.

**9:** Connect the black low voltage wire of the power supply to the black wires of the same connector with a wire nut.

**10:** Place all wire nut connections inside the junction box.

### Section Two: Prepare and Install the L-Picture Frame Power Connector

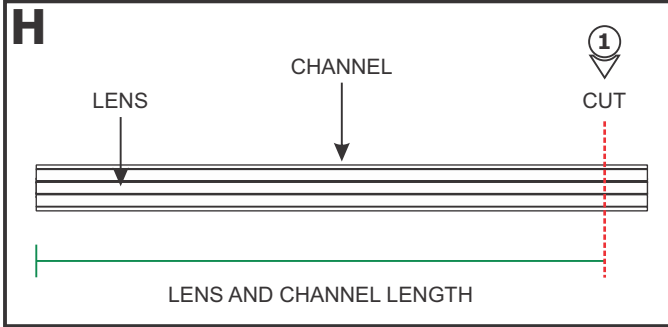

**1:** Refer to Section One in the TruLine .5A Channel and Lens instructions to measure and cut the channel and lens before continuing.

**2:** Slide a channel onto the joiner bars and tighten the remaining M3 set screws with a 1.5mm Allen wrench.

**3:** Repeat step 2 for the other end of the L-Picture Frame Power Connector.

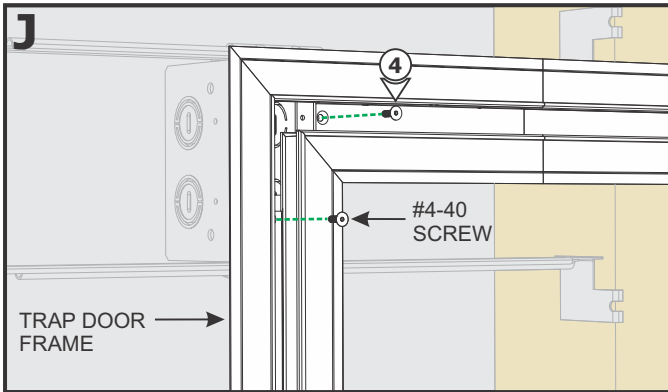
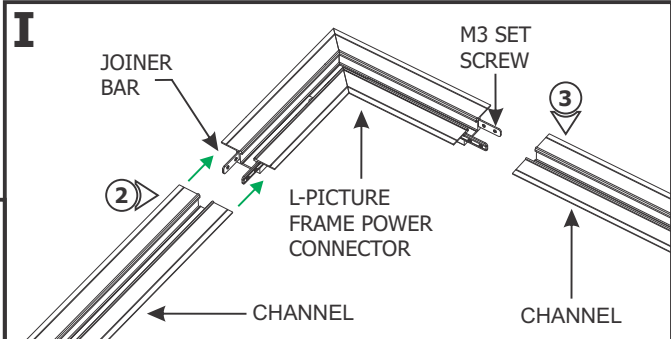

**4:** Attach the assembled trap door frame to the junction box using the #4-40 screws.

**NOTE:** Refer to Section Three in the TruLine .5A Channel and Lens instructions to plaster before continuing.

## Section Three: Install the LED Soft Strip

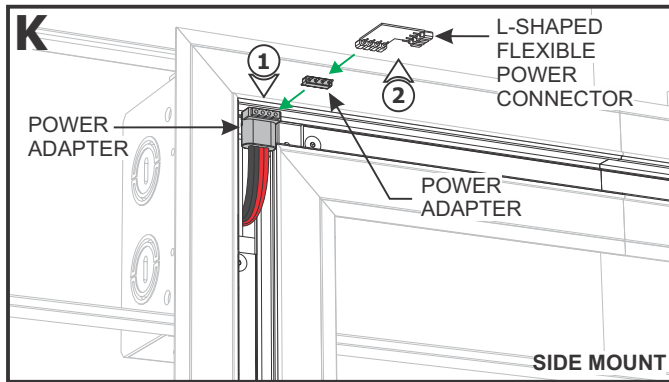

**NOTE:** Omit steps 1 and 2 if using the Snap & Light connector (LC-SLC) with Standard Soft Strip.

**NOTE:** L-Shaped Flexible Power Connector is used for installations that use B90 Connectors and when the LED strip is placed on the side of the channel. For alternate LED strip installation, see Section Five, Six or Seven.

1: Insert the male-to-male power adapter to the power connector.

2: Connect the L-Shaped Flexible Power Connector to the male-to-male power adapter.

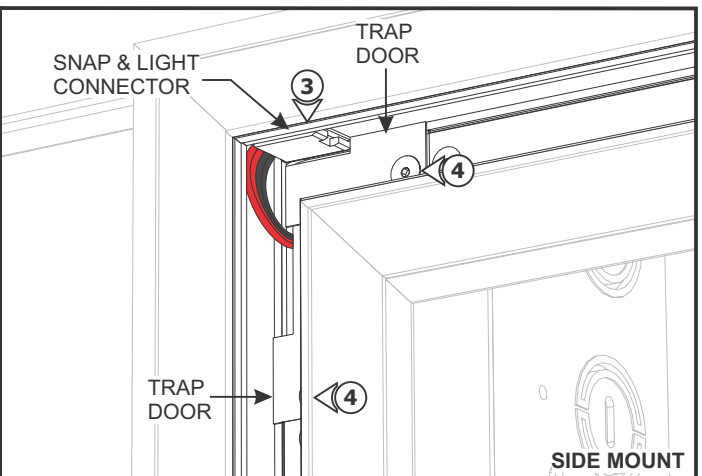
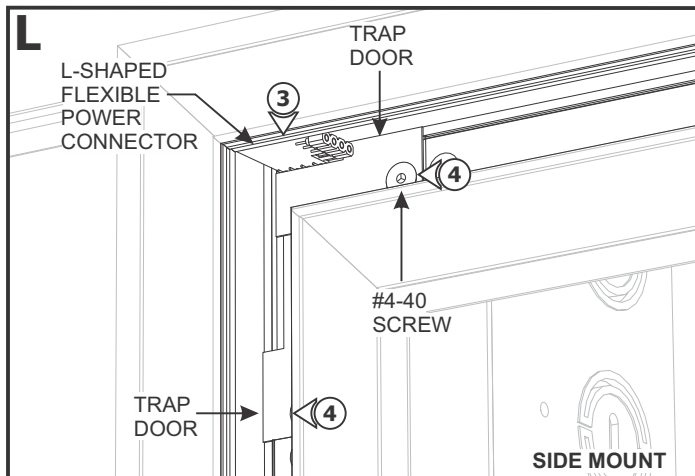

3: Place the power connection into the channel where the LED soft strip will be installed.

4: Replace the trap doors and secure with the #4-40 screws using a 1/16" Allen wrench.

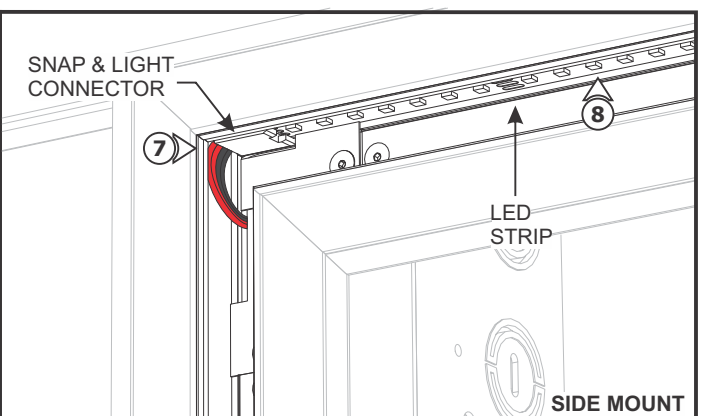
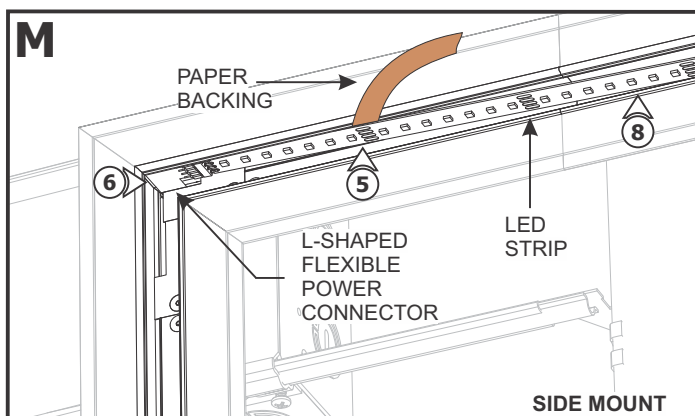

5: Carefully remove the backing from the LED soft strip, making sure not to remove the tape from the LED strip.

6: If using the B90 connectors, line up the red wire side of the power connector with the "+24VDC" marking on each LED strip. Push the male connector of the LED strip into the power connector.

7: If using Snap & Light connectors, insert the LED strip into the Snap & Light connector so that the "+24VDC" mark on the strip is aligned with the red wires. Push the LED strip completely into the contact pins.

8: Firmly press down the adhesive portion of the LED strip onto the channel surface while removing the rest of the backing, making sure there are no air bubbles that can cause surface irregularities.

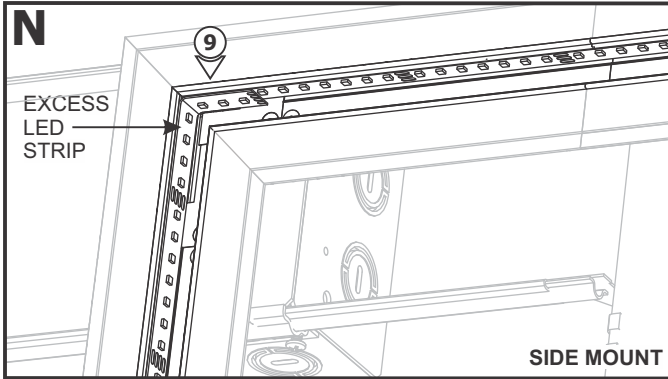

- 9: Trim excess LED strip **ONLY** at dashed cutting lines. Overlap excess soft strip at power connection to avoid dark spots in installation.
- 10: Insert lenses into the channel, ensuring all lenses are fully seated and properly aligned.

### Section Four: L-Picture Frame Dual Feed Power Channel Connector with B90 Connectors

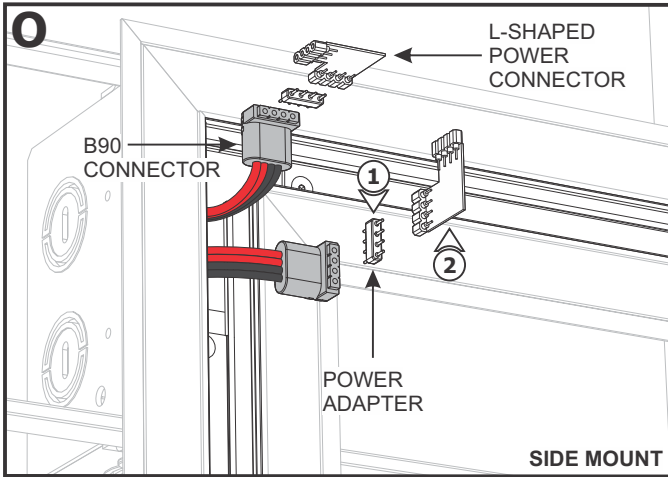

- NOTE:** Omit this section if using the Snap & Light connector (LC-SLC) with Standard Soft Strip. Refer to Section Five.
- 1: Insert the male-to-male power adapter to each power connector.
  - 2: Connect the L-Shaped Flexible Power connectors to each male-to-male power adapter.

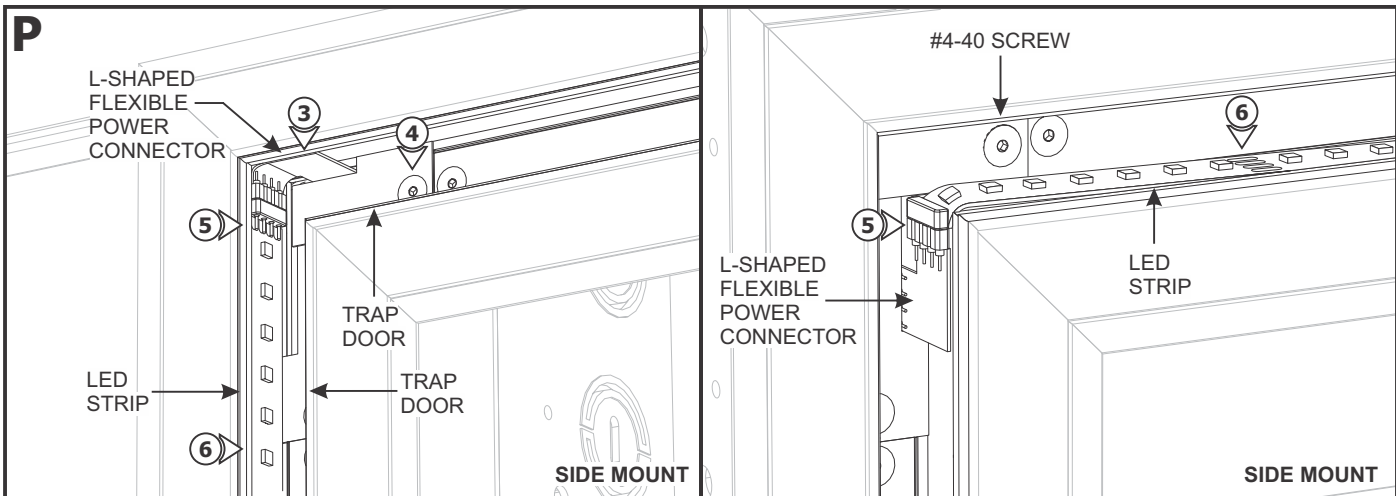

- 3: Place the power connection into the channel where the LED soft strip will be installed.
- 4: Replace the trap doors and secure with the #4-40 screws using a 1/16" Allen wrench.
- 5: Carefully remove the backing from the LED soft strip, making sure not to remove the tape from the LED strip. Line up the red wire side of the power connector with the "+24VDC" marking on each LED strip. Push the male connector of the LED strip into the L-Shaped Flexible Power Connector.
- 6: Firmly press down the adhesive portion of the LED strip onto the channel surface while removing the rest of the backing, making sure there are no air bubbles that can cause surface irregularities.

## Section Five: L-Picture Frame Dual Feed Power Channel Connector with Snap & Light Connector (LC-SLC)

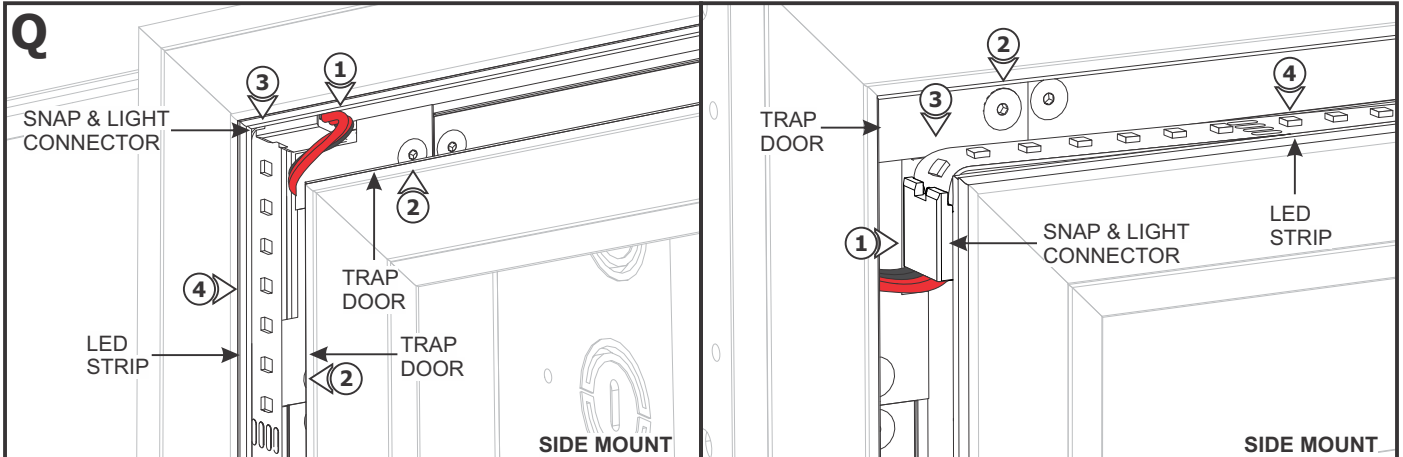

- 1: Place the power connection into the channel where the LED soft strip will be installed.
- 2: Replace the trap doors and secure with the #4-40 screws using a 1/16" Allen wrench.
- 3: Insert the LED strip into the Snap & Light connector so that the "+24VDC" mark on the strip is aligned with the red wire. Ensure the LED strip contacts align fully with the contact pins. Push the LED strip completely into the contact pins.
- 4: Firmly press down the adhesive portion of the LED strip onto the channel surface while removing the rest of the backing, making sure there are no air bubbles that can cause surface irregularities.

## Section Six: L-Picture Frame Dual Feed Power Channel Connector Install the LED Soft Strip on Bottom of Channel

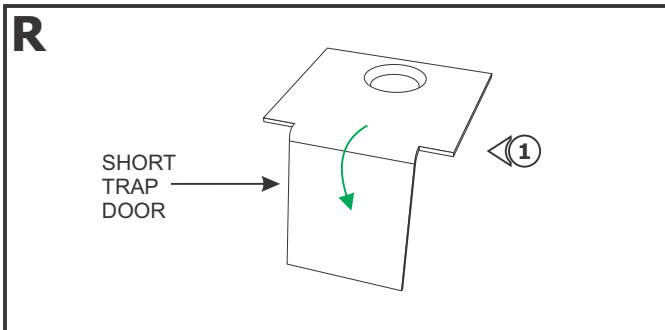

**NOTE:** This section is for installations where the LED strip will lay in the bottom of the channel.

- 1: Use pliers to bend the section of the short trap door cover ~90° to allow for access to power connections.

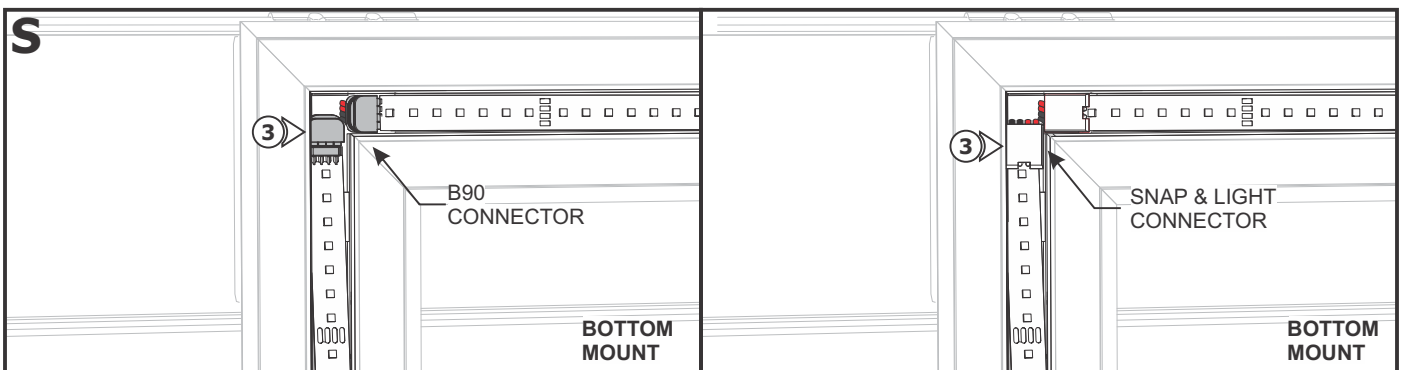

**NOTE:** This product can be used as a combination of side and bottom mount.

- 2: Attach the trap doors.
- 3: Refer to step 6 or 7 in Section Three to connect each LED strip to the power connectors.

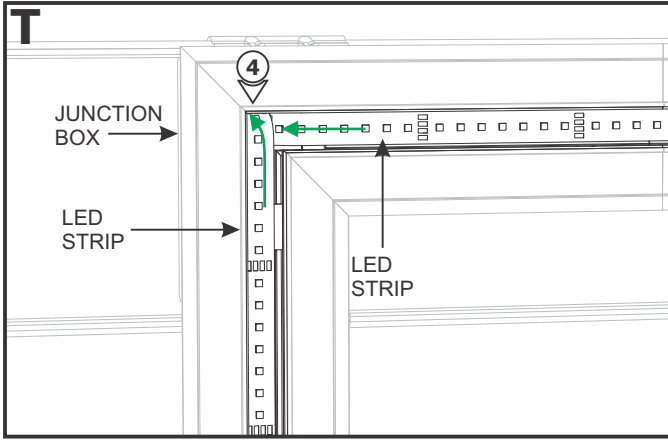

- 4: Place the connections inside the junction box to avoid dark spots.
- 5: Refer to step 8 in Section Three to properly place each LED strip onto the channel.

### Section Seven: Alternate Bottom Mount LED Soft Strip Installation

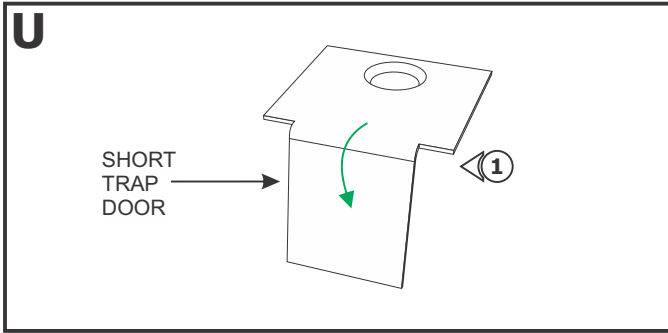

- 1: Use pliers to bend the section of the short trap door cover ~90° to allow for access to power connections.

- 2: Attach the trap doors to the L-Picture Frame Connector with the #4-40 screws.
- 3: Route excess LED strips from other power feeds into the junction box.

