

## Installation Instructions for Fast Jack Drop 2

### IMPORTANT SAFETY INSTRUCTIONS

- Use this fixture indoors only.
- This product must be installed by a qualified electrician.
- This product is used with Monorail, Monorail 2 Circuit, and Fast Jack canopy systems.
- **Make sure power to the system is turned OFF before installing the fixture.**

**SAVE THESE INSTRUCTIONS!**

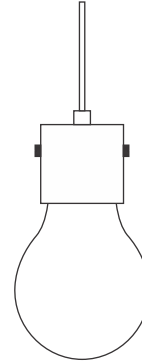

### Install the Lamp

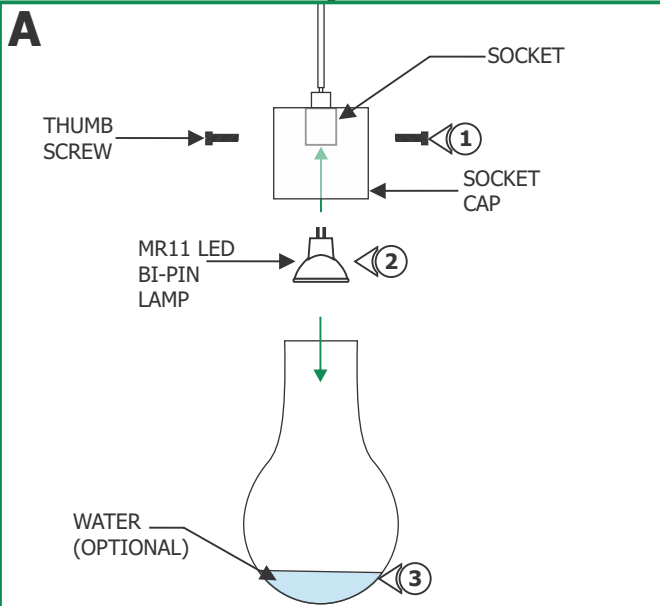

**NOTE:** Use **MAXIMUM** 3 Watt 12 VAC MR11 LED lamp or **MAXIMUM** 12/24VAC halogen lamp.

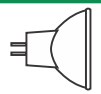

- 1: Loosen and remove two thumb screws to remove the fixture shade.
- 2: Align the MR11 lamp pins to with the socket holes. Push the lamp pins completely into socket holes.
- 3: If desired, fill the shade with up to 1" of water.
- 4: Replace the fixture shade into the socket cap. Align the socket cap holes with the fixture shade holes and tighten the thumb screws.

### Adjust the Fixture Height

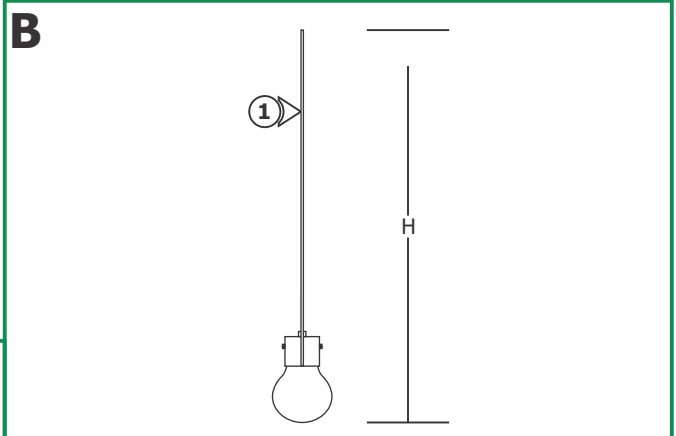

- 1: Cut the coaxial cable to the desired height (H) with a sharp cutter. The overall fixture height is measured from the bottom of the glass shade to the end of the coaxial cable.

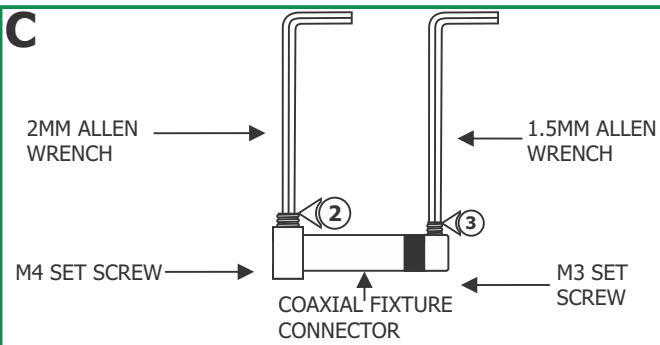

- 2: Loosen the M4 set screw on base of the coaxial fixture connector with the 2mm Allen wrench provided. **Do not remove this set screw.**
- 3: Remove the M3 set screw on tip of the connector with the 1.5mm Allen wrench provided.

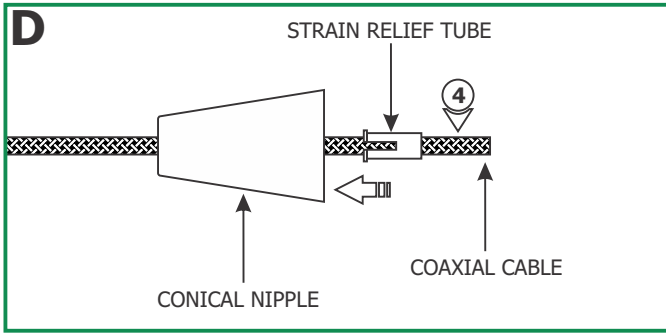

**4:** Feed the coaxial cable through the conical nipple and flared side of the strain relief tube. Slide the conical nipple and strain relief tube down the coaxial cable.

**5:** Feed the coaxial cable into the coaxial fixture connector. The coaxial cable will come to a stop point.

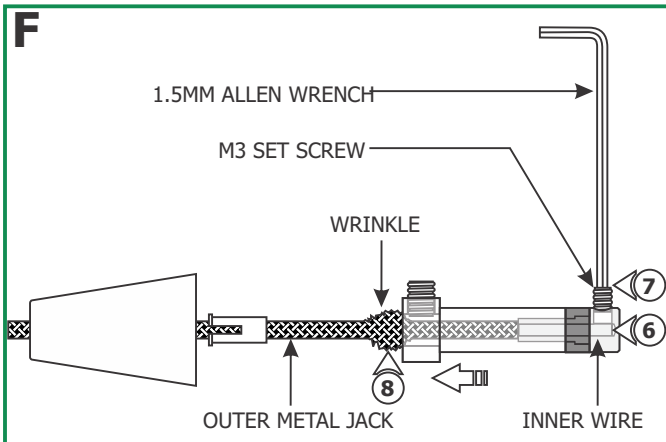
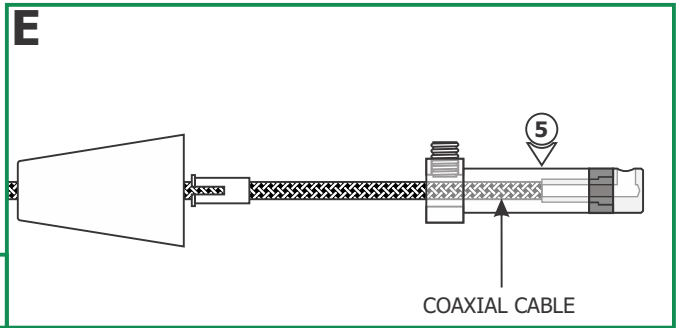

**6:** Keep feeding the coaxial cable in until the inner wire is visible in the screw hole of the fixture connector tip. The outer metal jacket will start to wrinkle.

**7:** Hold the fixture connector in place. Replace and tighten the M3 set screw on fixture connector tip with the 1.5mm Allen wrench.

**9:** Push the strain relief tube completely into the coaxial fixture connector. Make sure the slot on the strain relief tube is not inline with the M4 set screw.

**10:** Tighten the M4 set screw with the 2mm Allen wrench.

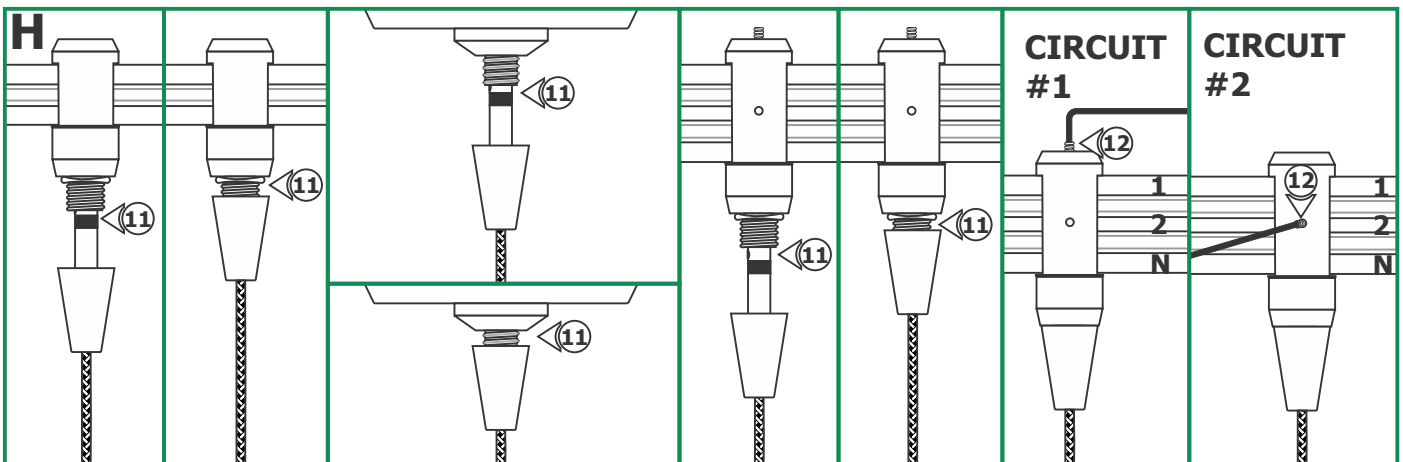
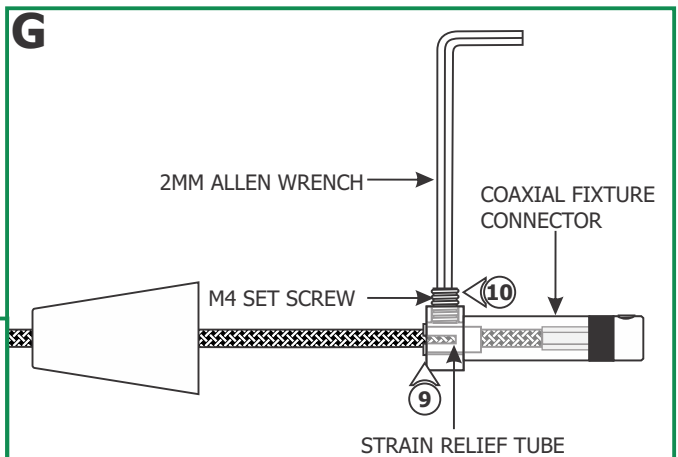

**11:** Use fingers to tighten the Fast Jack fixture connector into the Fast Jack system connector (Monorail, Monorail 2 Circuit, or canopy connector - Refer to the instructions provided with the system connector or canopy).

**12:** Refer to the instructions provided with the Monorail 2 Circuit fixture connector to choose Circuit #1 or Circuit #2.