

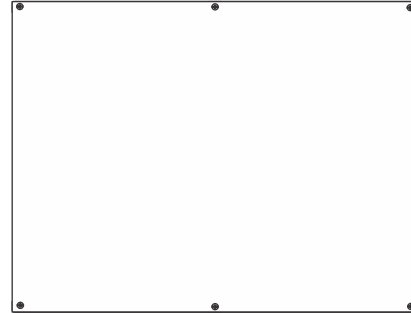

1718 W. Fullerton Chicago, IL 60614
 Ph: 773.770.1195 • Fax: 773.935.5613
 www.PureEdgeLighting.com • info@PureEdgeLighting.com
 © 2016 PureEdge Lighting. All Rights Reserved.

Installation Instructions for 4 X 96 Watt 24 Volt DC Power Supply with 0-10 Volt Dimming Module



SAVE THESE INSTRUCTIONS!



GENERAL INFORMATION

- **RISK OF FIRE:** This product must be installed by a qualified electrician. Turn the power to the electrical box off during installation. Read the "Important Safety Instructions" before installation.
- **NOTE:** To avoid overheating the power supply, install it in a ventilated remote location where air flows. Maintain proper spacing among power supplies when multiple power supplies are installed in the same remote location.
- This product is not suitable for wet locations. It is approved for the use at any height above the finished floor.
- A typical installation is shown. Specific installation must be in accordance with the local electrical codes.
- **TO REDUCE RISK OF FIRE,** it is important to wire the power supply for the system as described in this installation instruction.
- Load each power supply to **MAXIMUM 96** Watts.
- Use Philips Sunrise "SR1200ZTUNV" 0-10 volt controller to dim the LED soft strip (fixture).

IMPORTANT SAFETY INSTRUCTIONS

- Do not install this power supply in a wet location.
- To reduce the risk of the system overheating and possibly causing a fire, make sure all the connections are tight.
- Do not install *LED fixture closer than three inches or as specified in the *LED fixture installation instructions to curtains or similarly combustible materials. Keep insulation at least 3" away from the enclosure.
- Turn the electrical power off before modifying the lighting system in any way.
- The system is "ETL" listed for USA and Canada only when all the products used are supplied by Edge Lighting.
- * See LED fixture installation instructions for proper placement.

Install the Power Supply

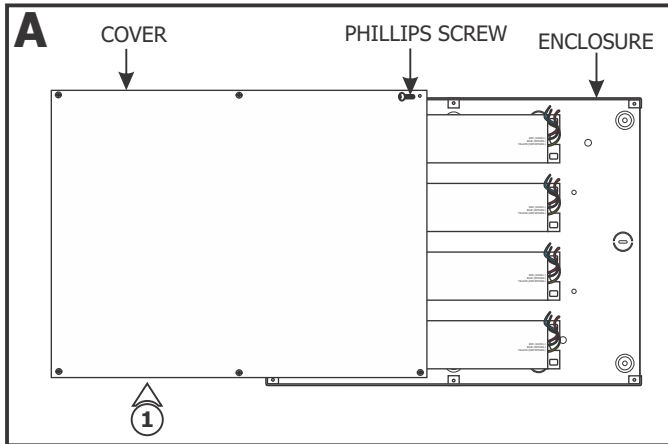

1: Loosen the six Phillips screws on the front of the power supply cover to slide the cover off of the enclosure.

2: Install conduits from the controller, main panel (line voltage) and soft strip to the power supply enclosure.

3: Connect the black, white, red, purple, and gray controller wires respectively to black, white, red, purple, and gray wires with a wire nut. The yellow controller wire is not used in this procedure. Cap the yellow controller wire with a wire nut. For three way switching, refer to the instructions provided with the controller.

4: Run the wires coming from the controller to the power supply enclosure.

5: Secure controller to the electrical box.

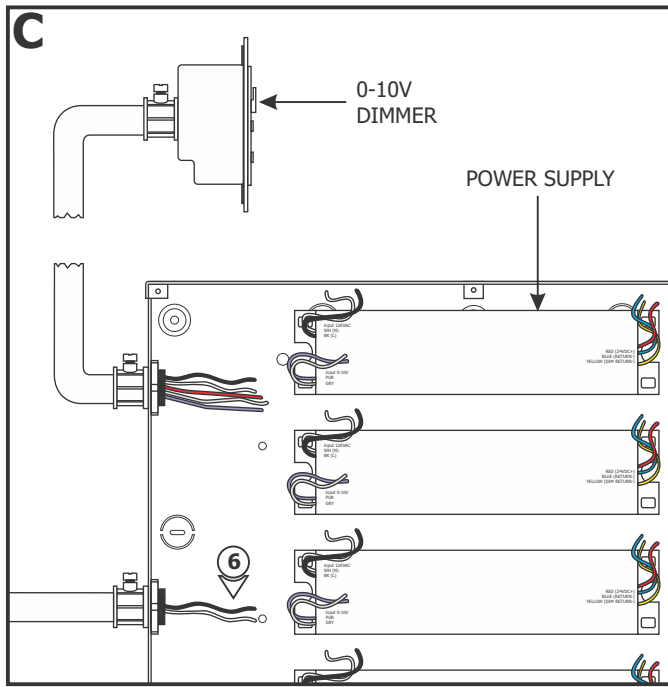
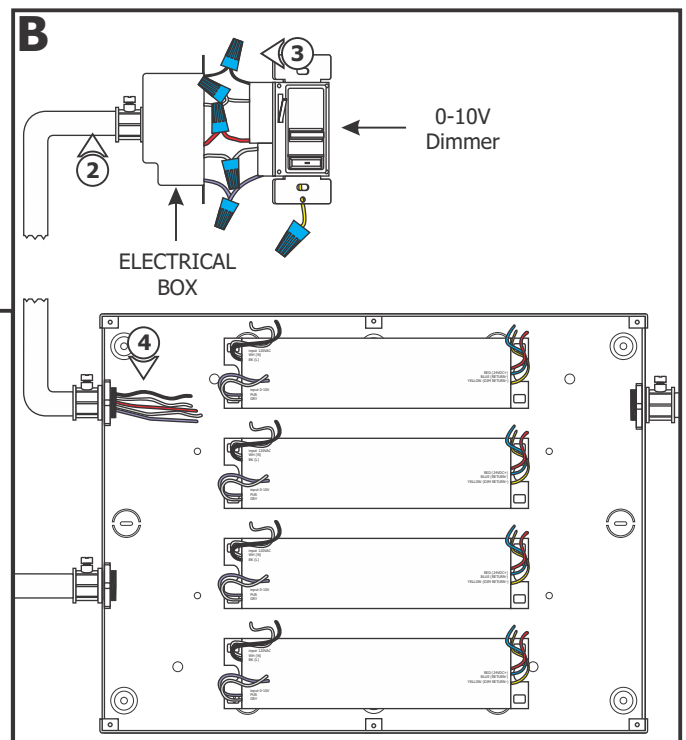

6: Run the 120 volt power line wires from the panel to the power supply case.

7: DO NOT connect the power wires to the panel at this time.

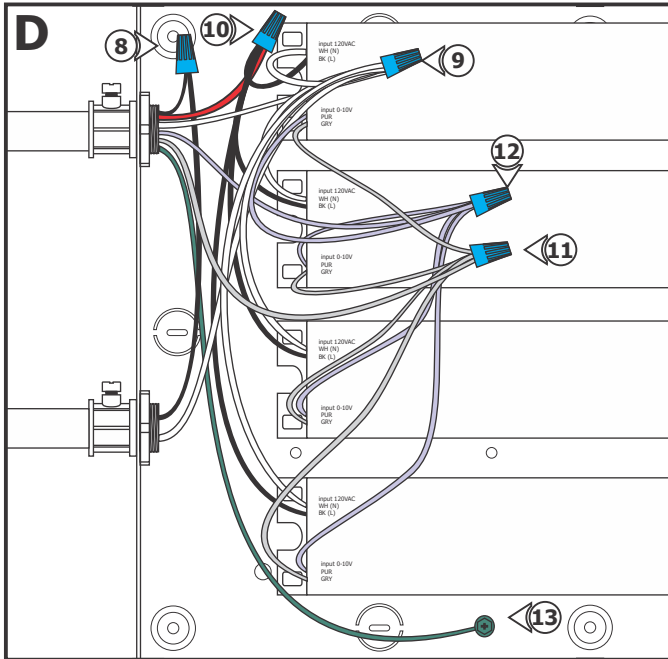

- 8:** Connect the black controller wire to the 120 volt hot wire with a wire nut.
- 9:** Connect the white controller wire to the 120 volt neutral wire and white wire of each power supply with a wire nut.
- 10:** Connect the red controller wire to the black wire of each power supply with a wire nut.
- 11:** Connect the gray controller wire to the gray wire of each power supply with a wire nut.
- 12:** Connect the purple controller wire to the purple wire of each power supply with a wire nut.
- 13:** Make sure the power supply is grounded in accordance with local electrical codes.

NOTE: Use only 24 volt Warm White LED soft strip with this power supply.

- 14:** Use the "Low Voltage Wire Size Chart" below to determine the proper wire size connecting the power supply to the LED soft strip.
- 15:** Run the proper size red and black wires from the LED soft strips to the power supply case.
- 16:** Cap the blue power supply with a wire nut. This wire is not used.
- 17:** Connect the red wire from one power supply to the red wires from one LED soft strip with a wire nut. Connect the yellow wire from the same power supply to the black wires from the same LED soft strip with a wire nut.
- 18:** Repeat steps 16 and 17 for the other power supplies and the other LED soft strips.

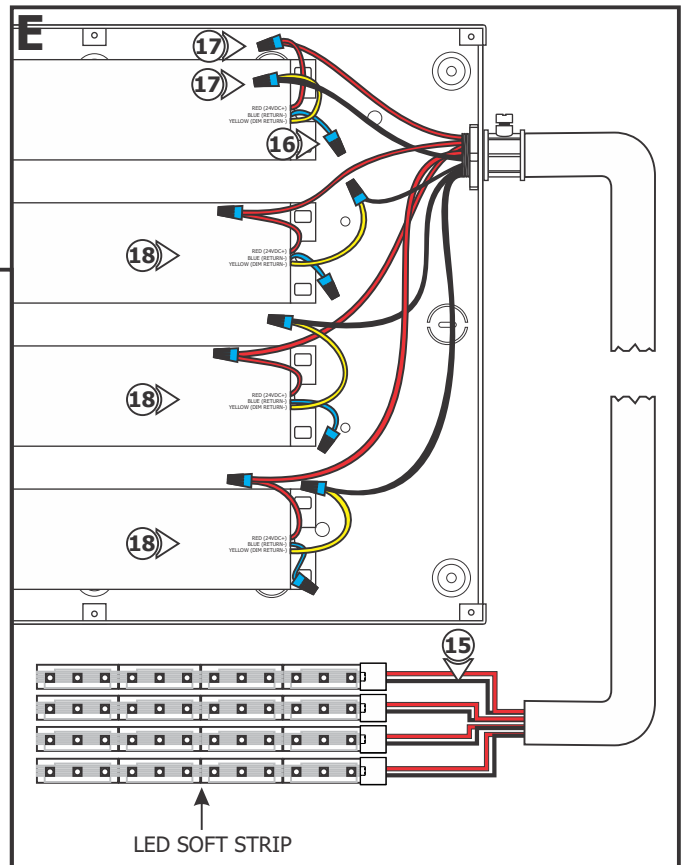

96W, 24VDC LOW VOLTAGE WIRE SIZE CHART

3% VOLTAGE DROP	WIRE LENGTH IN FT	UP TO 33FT	34FT-52FT	53FT-86FT	87FT-130FT
	WIRE SIZE	14 AWG	12 AWG	10 AWG	8 AWG
	VOLTAGE AT END OF THE WIRE	23.28 VDC	23.29 VDC	23.28 VDC	23.28 VDC

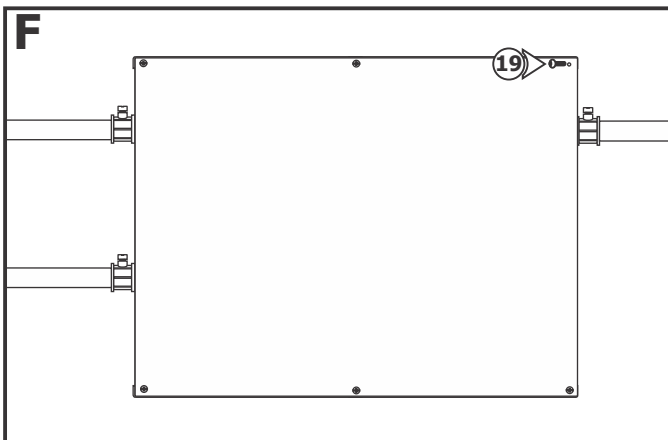

19: Replace the power supply cover and secure it by tightening the Phillips screws.

20: At this time, connect the 120 volt wires to the circuit box panel.

