

Installation Instructions for **Monorail Fast Jack Fixture Connector**

IMPORTANT INFORMATION

- This product is ETL listed for indoor dry locations.
- The product is intended to be used with Edge Lighting Monorail systems only.

SAVE THESE INSTRUCTIONS!

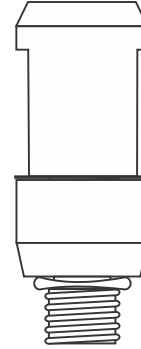

A

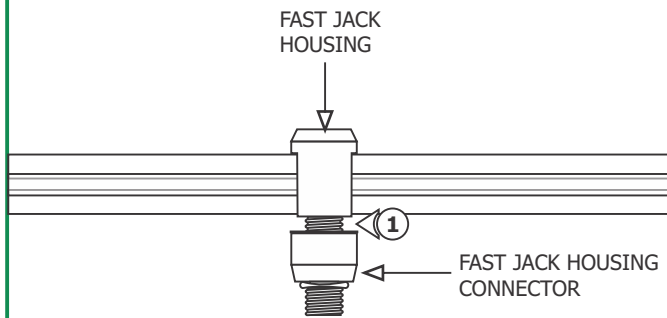

- 1:** Place the Fast Jack housing onto the Monorail and use fingers to tighten the Fast Jack housing connector to the Fast Jack housing. **Make sure that the Fast Jack housing connector is not cross threaded.**

B

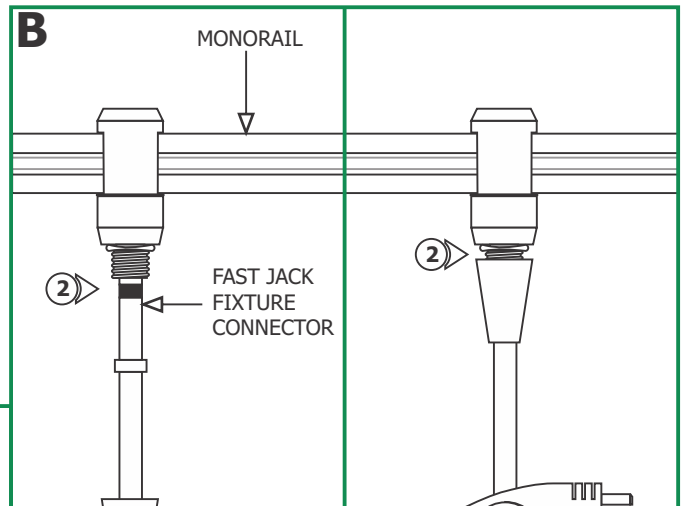

- 2:** Use fingers to tighten the Fast Jack fixture connector into the Fast Jack housing connector.