

Installation Instructions for Millwork Light Channel, 12VDC

IMPORTANT INFORMATION

- This instruction shows a typical installation.
- Per NEC Article 410.16(A)(1)(3) & 410.16(C)(5). Approved for Closet Storage Areas.

SAVE THESE INSTRUCTIONS!

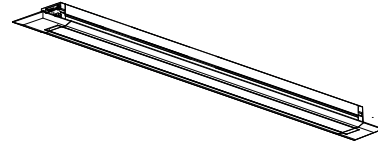

Install the Light Channel

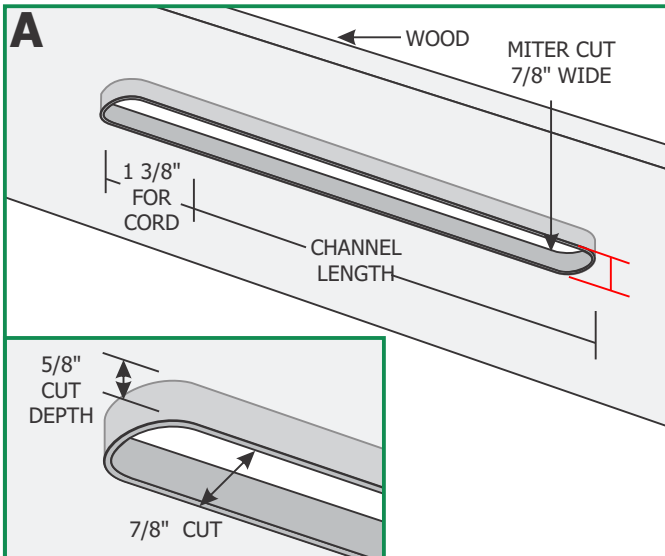

- 1:** Determine the location of the Millwork Light Channel on the wood.

NOTE: The Millwork Light Channel needs to be installed onto a 3/4" thick wood. The cut out slot must be 7/8" wide and 5/8" deep. Add 1-3/8" to the length of the channel to accommodate the power cord spacing.

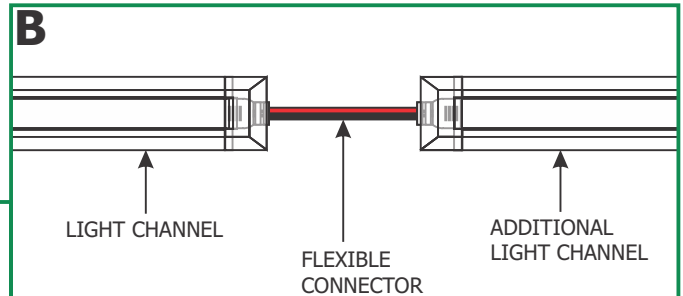

NOTE: Multiple light channels up to total of 25 feet long can be connected together with the flexible connectors. Refer to the instructions provided with the flexible connectors.

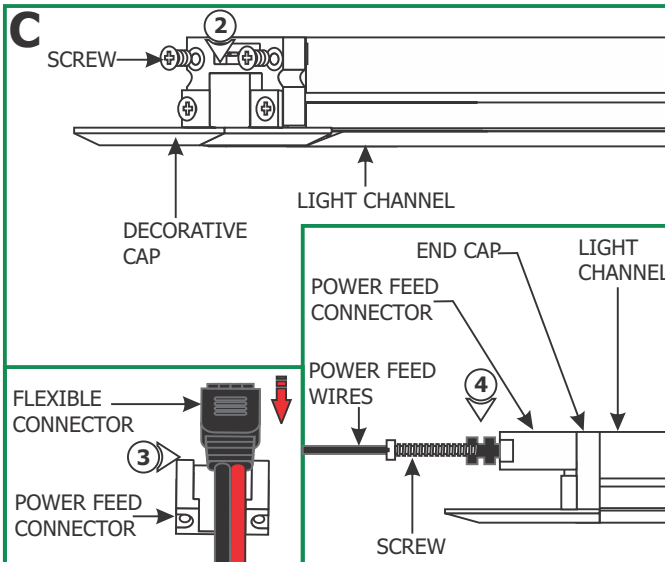

NOTE: The power feed cable can be mounted to either the female or male end of the channel.

- 2:** Remove the two screws on the bottom of the light channel (not the screws holding the decorative cap).
- 3:** Place the male end of the power cord in the cord grip if connecting to the female end of the light channel, or place the female end of the power cord in the cord grip if connecting to the male end of the light channel.
- 4:** Push the cord completely into the light channel power end cap pins and secure the cord grip to the light channel by tightening the two screws (provided with cord grip) through the cord grip into the light channel power end cap.

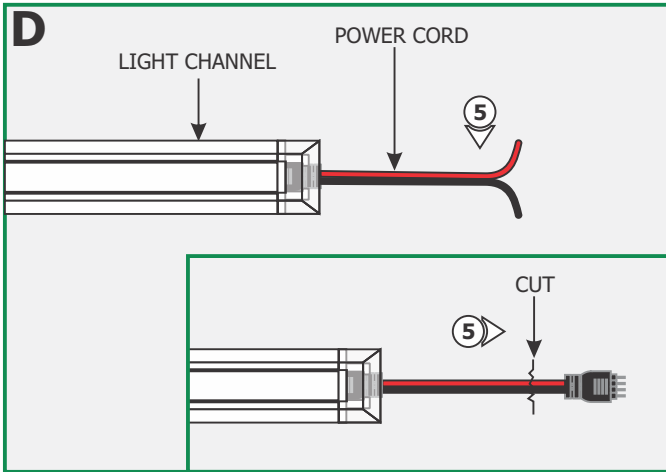

5: Cut the other end of the power cord (male or female) and discard it. Strip the wire end for connecting it to the power supply.

- 6:** Drill one end of the slot with 7/32 bit to run the light channel wire.
- 7:** Feed the wires through the hole and snap the light channel into the slot, make sure all clips are tight. If necessary slide the mounting clip to the appropriate area.
- 8:** Follow the instructions provided with the power supply to power up the light channel.

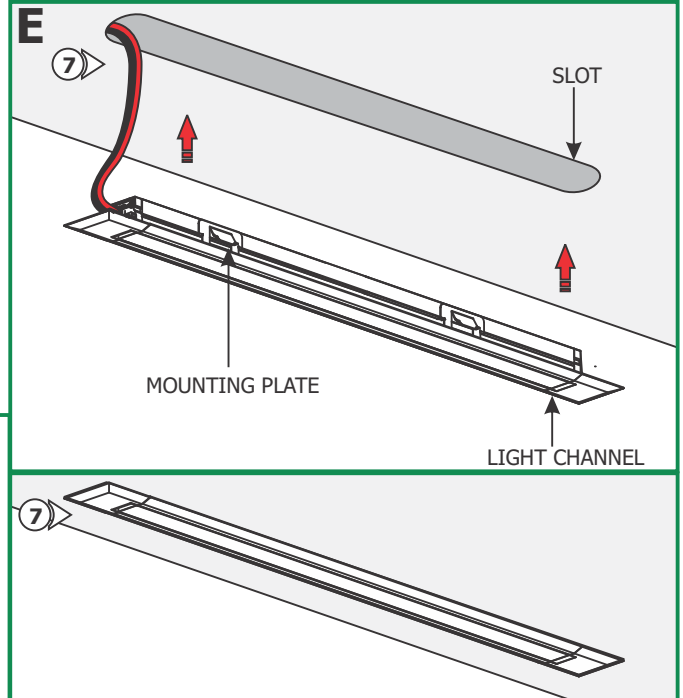

IMPORTANT INFORMATION REGARDING INSTALLATION AND REWORK OF SOFT STRIP LED

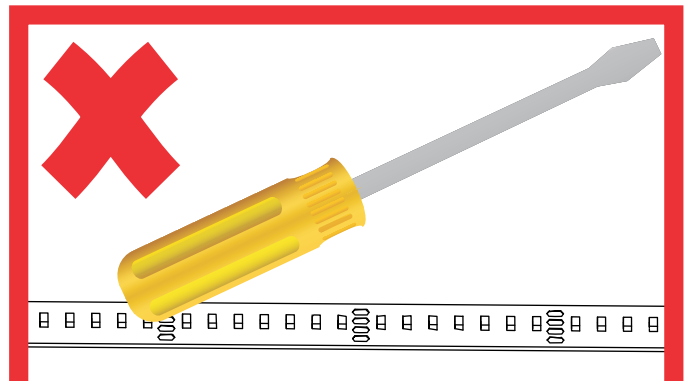
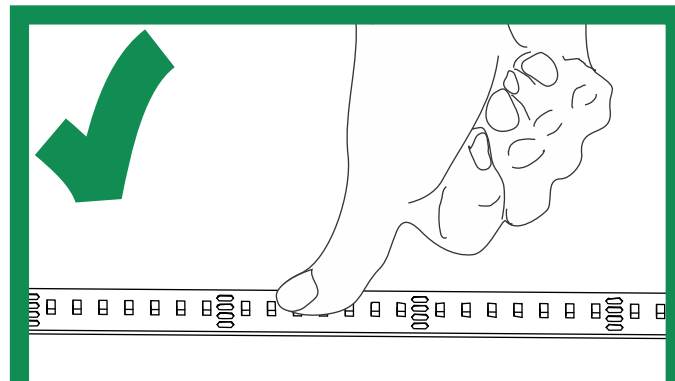
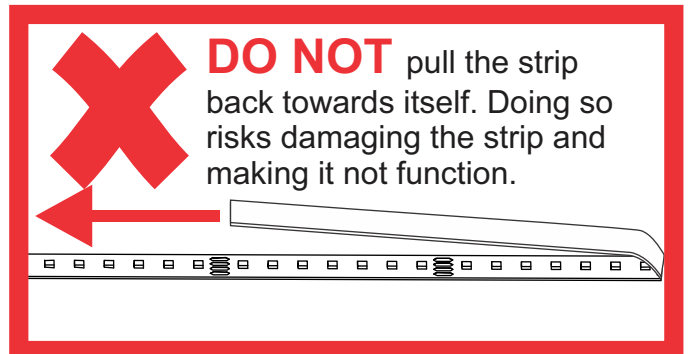
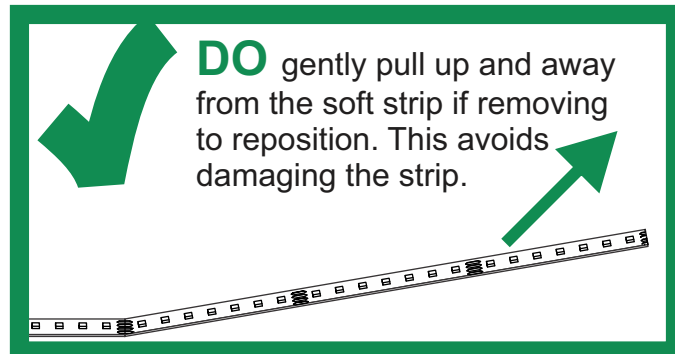

Replacing/Repositioning the Soft Strip

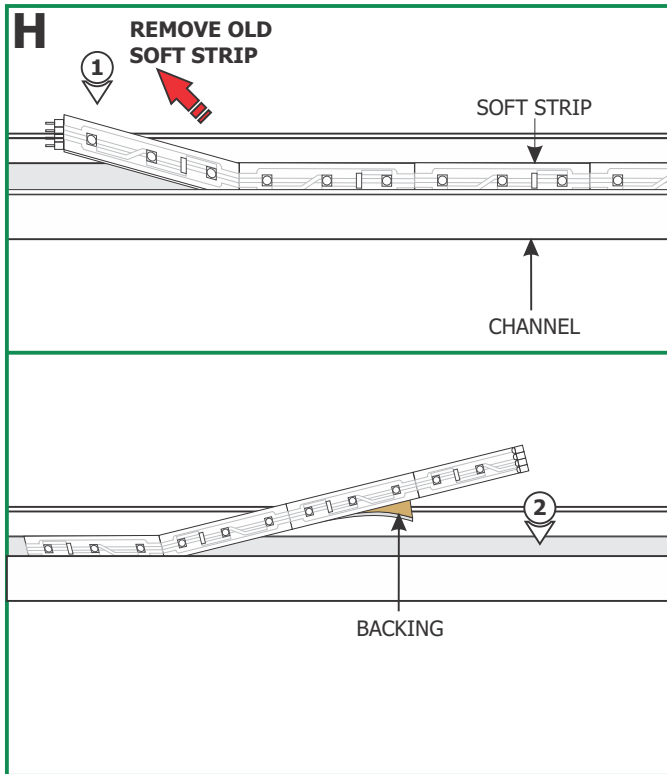

1: Carefully pull existing old Soft Strip completely off the channel.

2: If there is Soft Strip residue on the channel apply in moderation WD-40, or Goo Gone, or a mixture of warm water and lemon oil to the corner of a clean, dry towel. Gently buff the area containing the adhesive residue with small circular motion until it is completely removed.

NOTE: Avoid bending the soft strip in sharp vertical angles which may damage the LEDs. Soft Strips do not bend horizontal. Use proper directional connectors for horizontal turns.

3: Carefully remove the backing from the new LED soft strip, make sure not to remove the tape from the soft strip. Firmly press down the adhesive portion of the soft strip onto the channel while removing the rest of the backing, making sure there are no air bubbles that can cause surface irregularities.