

# STRAIGHT RAIL

## MONORAIL/MONORAIL WALL

DESIGNED BY GREGORY KAY

REV 12.21.18

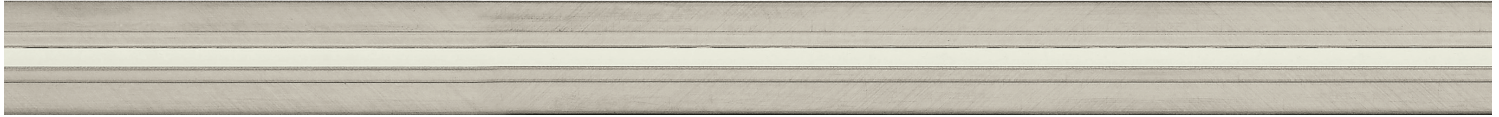

SATIN NICKEL



ANTIQUE BRONZE

### DESCRIPTION

Straight Rail, Monorail System Conductor, in 24" (61cm), 48" (122cm) or 96" (243.8cm) lengths is field cuttable and hand-bendable. Rated for maximum of 25 amps (300 watts at 12 volts, 600 watts at 24 volts). Monorail has a max run length of 30' in any direction. Pair of Conductive Connectors included with each section to connect to other Rail sections. Satin Nickel or Antique Bronze finish with Clear Insulator.

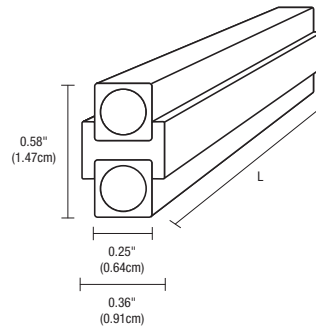

### FINISHES



**BZ**  
Antique  
Bronze

**SN**  
Satin  
Nickel

### WEIGHT

- 24": 0.3 lbs. (0.13 kg)
- 48": 0.6 lbs. (0.27 kg)
- 96": 1.2 lbs. (0.54 kg)

### LABELS

Assembled in America



System	Length	Finish
<b>M</b>	<b>24</b>	<b>SN</b>
M Monorail	24 24" (61cm) 48 48" (122cm) 96 96" (243.8cm)	BZ Antique Bronze SN Satin Nickel

PROJECT	FIXTURE TYPE	DATE
---------	--------------	------