



1718 W. Fullerton Chicago, IL 60614
 Ph: 773.770.1195 • Fax: 773.935.5613
 www.PureEdgeLighting.com • info@PureEdgeLighting.com
 © 2016 PureEdge Lighting. All Rights Reserved.

Installation Instructions for Pipeline Suspension with Power - End Feed

P1SD_P-E_

IMPORTANT INFORMATION

- This product is ceiling mount only.
- This product is dimmable with single electronic low voltage dimmer.

SAVE THESE INSTRUCTIONS!



Section One: 4" Flush Canopy Version

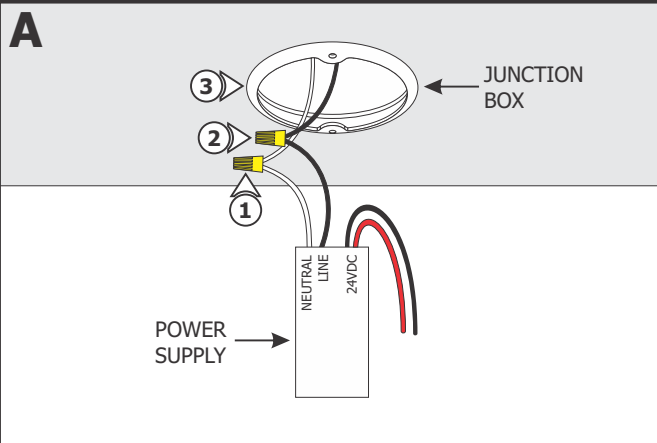

NOTE: Before beginning any electrical work, ensure that power to the junction box is turned off.

NOTE: Omit this section if using the 5" and 6" Surface Mount Canopy. Refer to Section Two.

- 1: Connect the white wire of the power supply to the 120VAC neutral wire with a wire nut.
- 2: Connect the black wire of the power supply to the 120VAC line wire with a wire nut.
- 3: Place the power supply and wires inside the junction box.

- 4: Feed the low voltage wires from the power supply through the crossbar center hole.
- 5: Mount the crossbar to the junction box holes with two #8-32 screws.
- 6: Make sure the crossbar is grounded in accordance with local electrical codes.

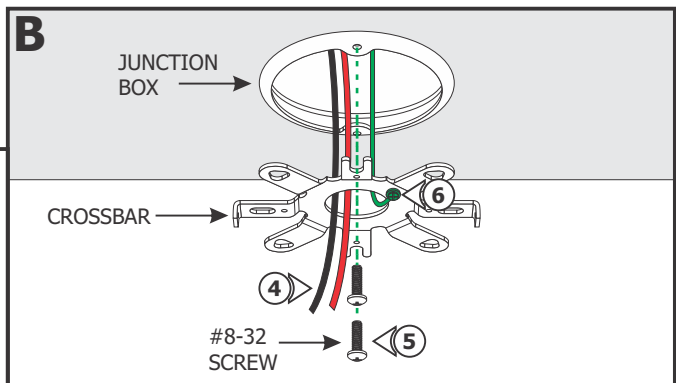

Section Two: 5" and 6" Surface Mount Canopy Version

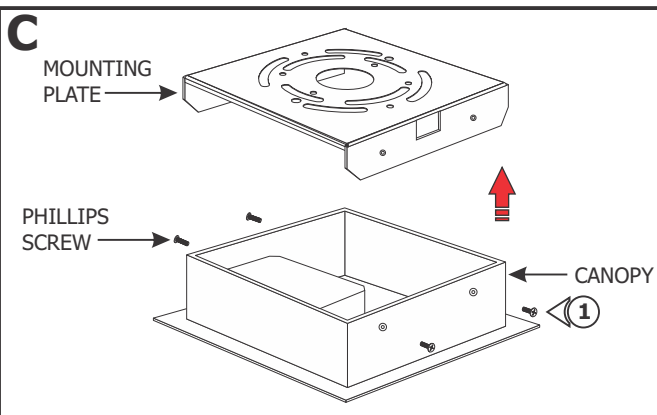

- 1: Remove the four Phillips screws from the canopy to remove the mounting plate.

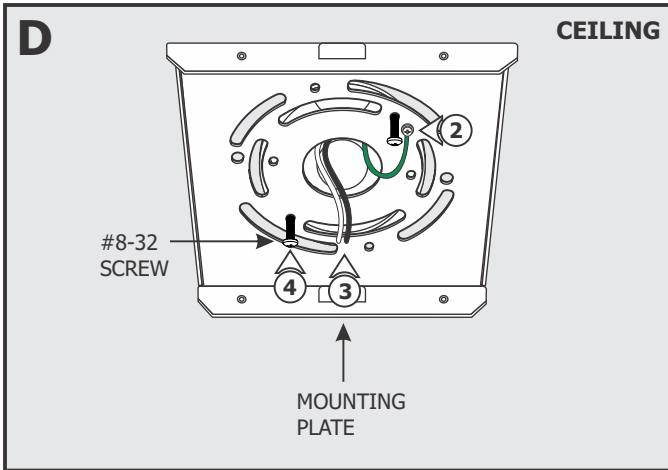

- 2:** Make sure the mounting plate is grounded in accordance with local electrical codes.
- 3:** Feed the 120VAC power wires through the mounting plate center hole.
- 4:** Secure the mounting plate to the junction box using the #8-32 screws.

Section Three: Install the Standoff

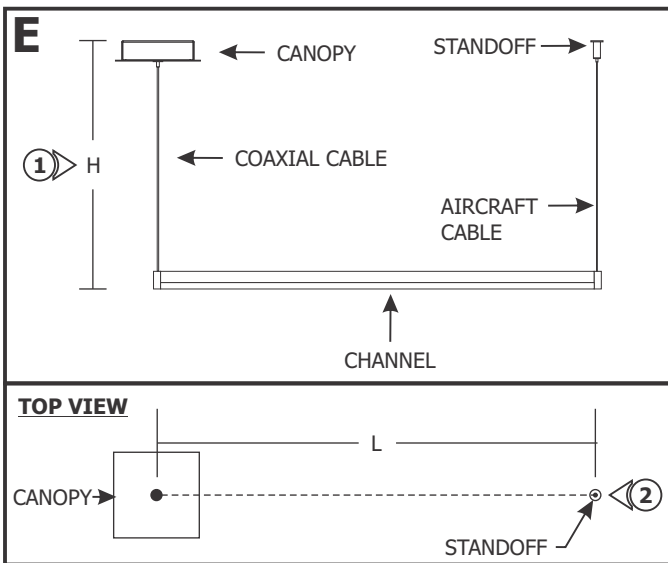

- 1:** Determine the fixture height (H) from the bottom of the channel to the top of the canopy.
- 2:** Determine the fixture length (L). Measure the distance between the coaxial cable and aircraft cable on the channel. Mark the standoff location on the ceiling from the center of the junction box.

NOTE: Omit Section Seven if the channel is made out of a single piece.

- NOTE:** Omit steps 3 through 7 if using support canopy. Refer to Section Four: Install the Support Canopy.
- 3:** For each provided standoff, tap the anchor onto the marked location up to the threaded portion with a hammer.
 - 4:** Screw in the threaded portion of the anchors with a Phillips screwdriver.

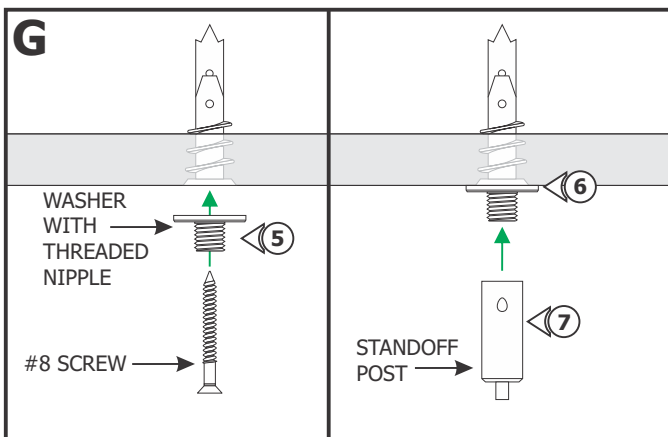
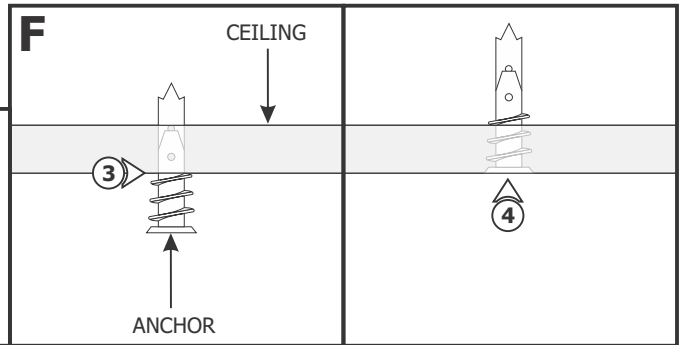

- 5:** Feed the #8 screw through the washer with threaded nipple into the anchor.
- 6:** Tighten the #8 screw completely into the anchor.
- 7:** Tighten the standoff post completely onto the threaded nipple.

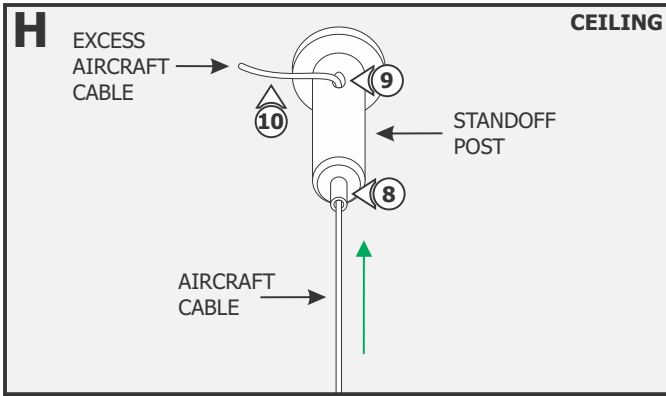

8: Feed the aircraft cable coming from the channel through the standoff post.

9: Adjust the fixture height by pushing the tab and pulling the aircraft cable out of the side of the standoff post. Release the tab to secure the cable in place.

10: If necessary, trim excess aircraft cable using sharp cutters.

11: For additional support, feed the aircraft cable through the Suspension Cable Adapter. Slide the Suspension Mounting Clip over the channel and adjust the position by moving it across the channel.

12: Repeat steps 3 through 10 to install the standoff.

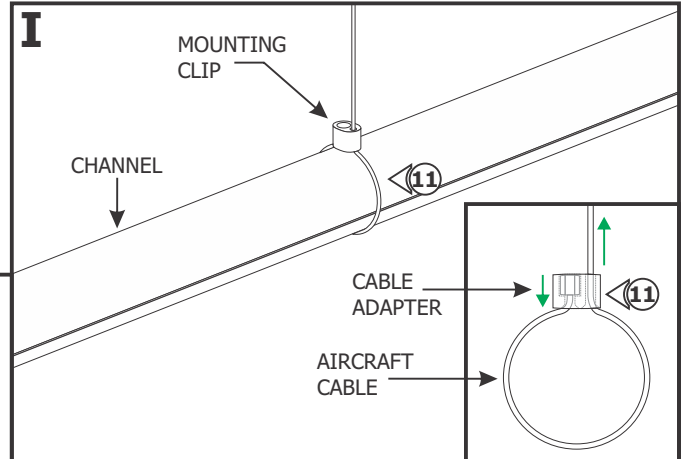

Section Four: Install the Support Canopy (E2 Version)

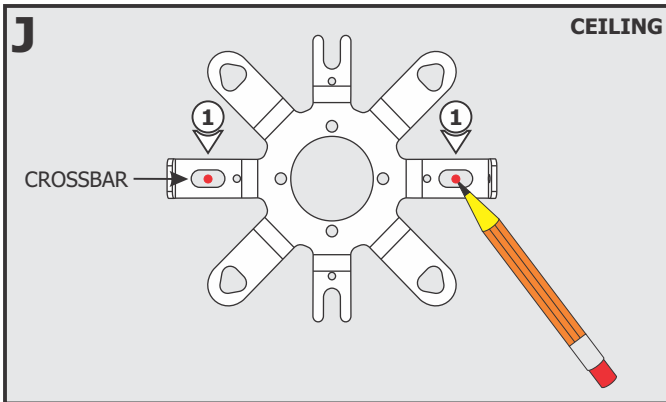

NOTE: 4" Support Canopy shown. Omit steps 1 through 5 if using 5" or 6" Surface Mount Support Canopy.

1: Mark points through the crossbar holes onto the ceiling. These points are used for the anchors.

2: Tap the anchors onto the marked points up to the threaded portion with a hammer. Screw in the threaded portion of the anchors with a Phillips screwdriver.

3: Secure the crossbar to the anchors using the two #8 screws.

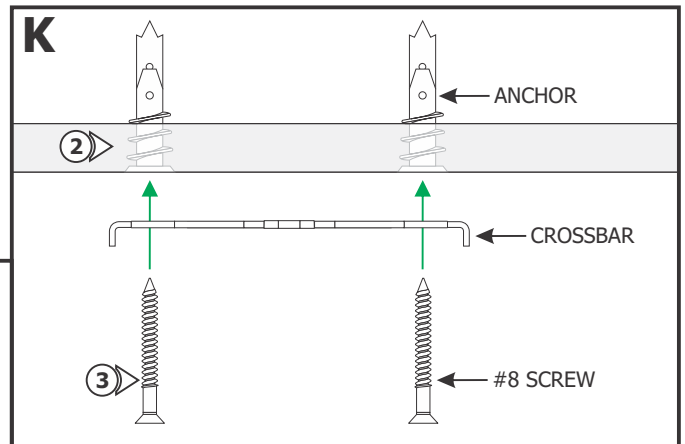

4: Align the canopy with the crossbar and secure it using the two #4-40 screws using a 1/16" Allen wrench.

5: Refer to steps 8 through 10 in Section Three to adjust the fixture height.

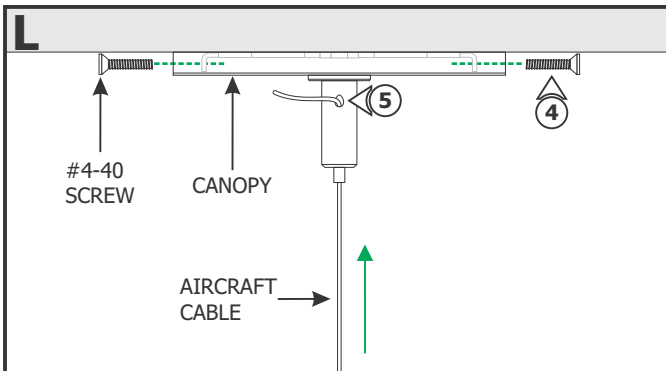

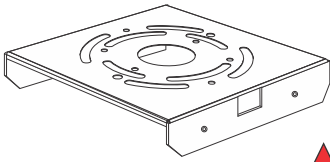
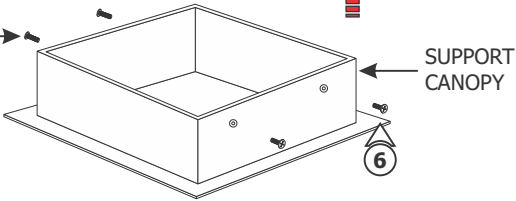
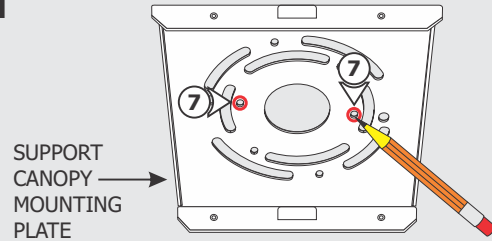
MMOUNTING
PLATEPHILLIPS
SCREWSUPPORT
CANOPY**NOTE:** 5" and 6" Support Canopies shown.**6:** Remove the four Phillips screws from the canopy to remove the mounting plate.**N****CEILING**SUPPORT
CANOPY
MOUNTING
PLATE**7:** Mark points through the mounting plate holes onto the ceiling. These points are used for the anchors.**8:** Tap the anchors onto the marked points up to the threaded portion with a hammer. Then screw in the threaded portion with a Phillips screw driver.**CEILING**

ANCHOR

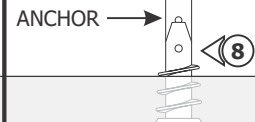

ANCHOR

O**CEILING**

#8 SCREW

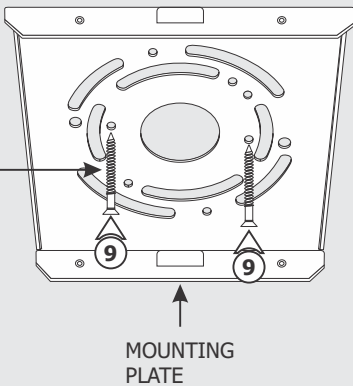
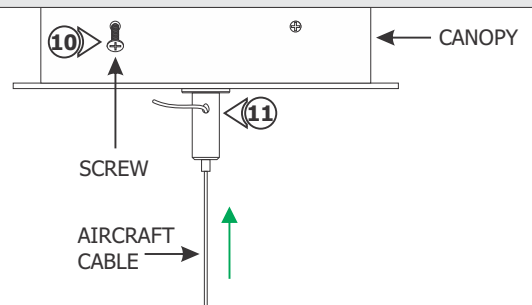
MOUNTING
PLATE**9:** Secure the mounting plate to the ceiling using the #8 screws.**10:** Align the support canopy holes and secure the canopy in place by tightening the four screws.**11:** Refer to steps 8 through 10 in Section Three to adjust the fixture height.**P**

10

SCREW

AIRCRAFT
CABLE

← CANOPY

11

Section Five: Install the Coaxial Cable

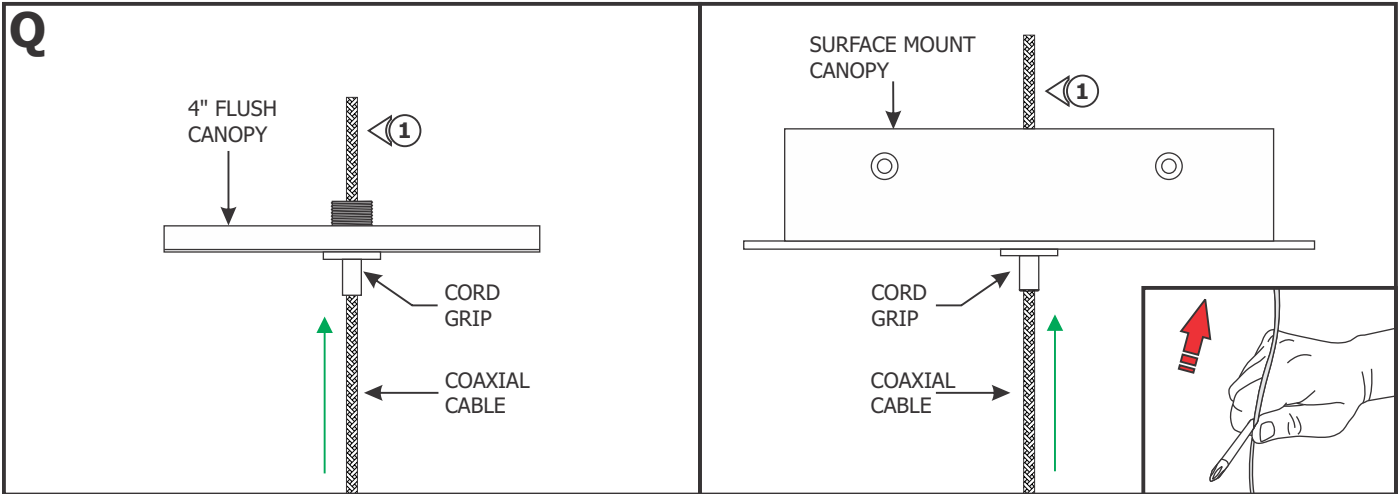

NOTE: If cable is curled or kinked, straighten by holding between the shaft of a screwdriver and thumb and pulling the cable through (see inset).

1: Push the coaxial cable through the cord grip of the canopy.

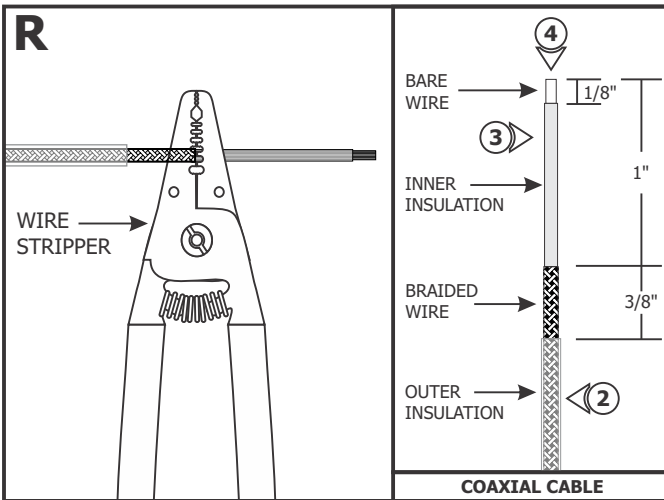

NOTE: Scan the QR Code to watch the video clip of the following steps or visit http://www.edgelighting.com/videos/cxc_connector/

2: Use the 18AWG hole of the wire stripper to remove 1-3/8" of the outer insulation to expose the braided wire.

3: Use the 18AWG hole of the wire stripper to remove 1" of the braided wire making sure not to nick the inner wire insulation.

4: Use the 20AWG hole of the wire stripper to remove 1/8" of the inner insulated wire.

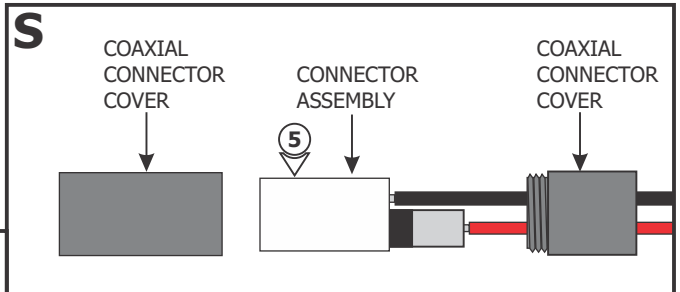

5: Unscrew the coaxial connector covers and remove from the connector assembly.

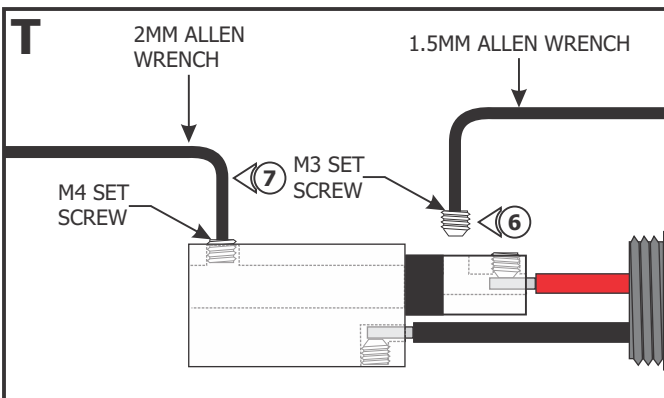

6: Using the provided 1.5mm Allen wrench, remove the M3 set screw from the coaxial connector assembly.

7: Using the provided 2mm Allen wrench to loosen (do not remove) the M4 set screw.

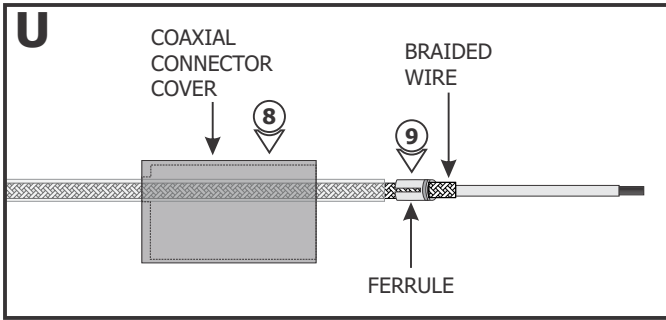

8: Slide the connector cover over the coaxial cable.

9: Place the ferrule over the 3/8" braided wire of the coaxial cable.

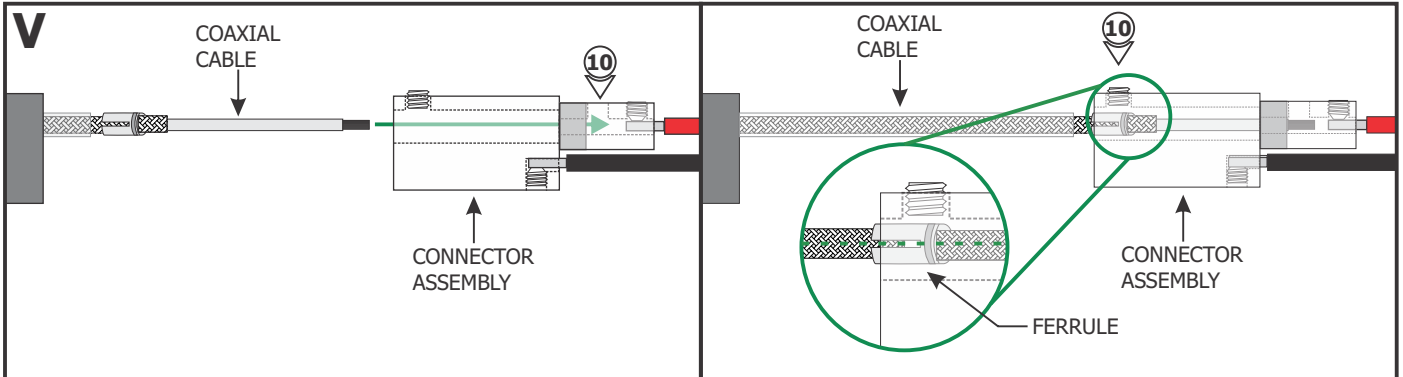

10: Insert the coaxial cable into the coaxial connector until the wires of the center conductor are visible through the M3 set screw hole.

NOTE: Ensure that the split in the ferrule is aligned 90° from the M4 set screw (see inset).

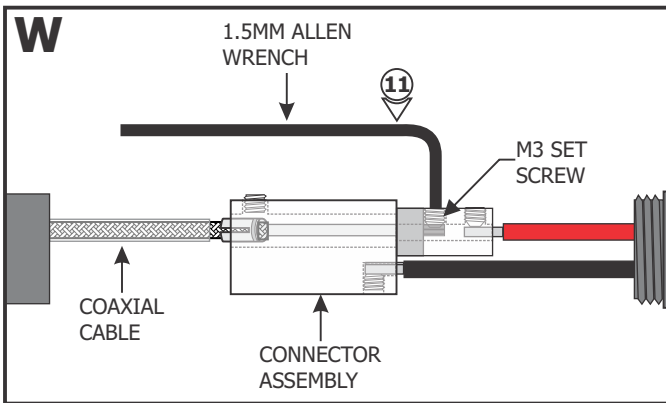

11: Use the provided 1.5mm Allen wrench to replace and securely tighten the M3 set screw.

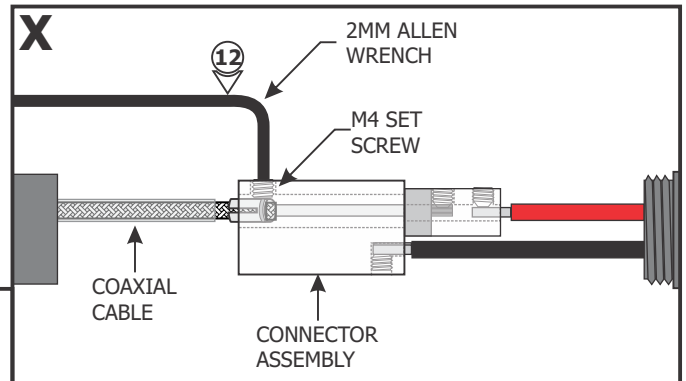

12: Use the provided 2mm Allen wrench to securely tighten the M4 set screw until it squeezes the wire ferrule tightly to the coaxial cable.

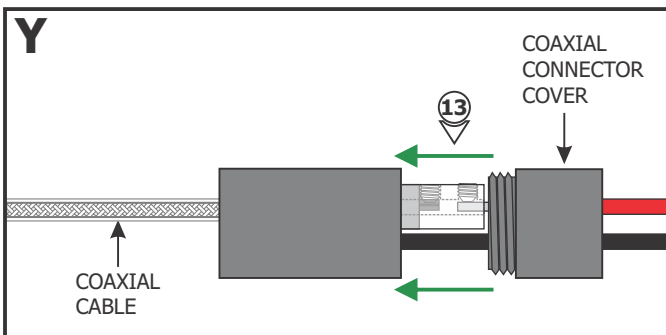

13: Replace the coaxial connector cover and tighten into place.

NOTE: For 5" and 6" Surface Mount Canopies, make sure that the coaxial connector is placed inside the power supply housing. **DO NOT** place it inside the junction box.

Section Six: Power the Fixture

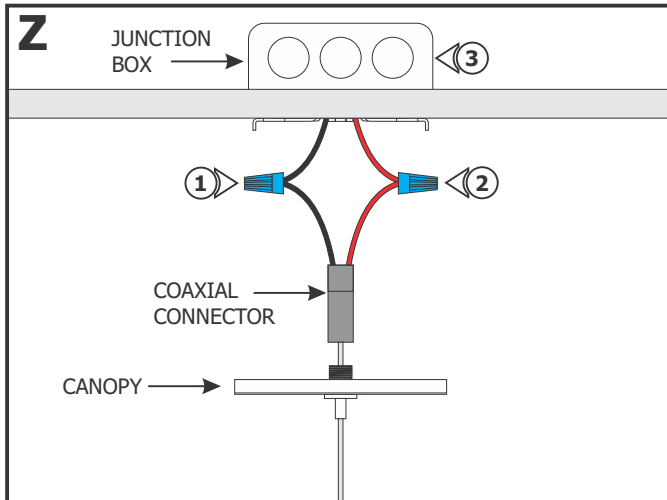

NOTE: Omit steps 1 through 4 if using 5" and 6" Surface Mount Canopies. Adjust fixture height by following step 9 below.

- 1:** Connect the black wire of the coaxial connector to the -24VDC power supply wire with a wire nut.
- 2:** Connect the red wire of the coaxial connector to the +24VDC power supply wire with a wire nut.
- 3:** Place all connections inside the junction box.

- 4:** Align the canopy with the crossbar and secure it with the two #4-40 screws using a 1/16" Allen wrench.

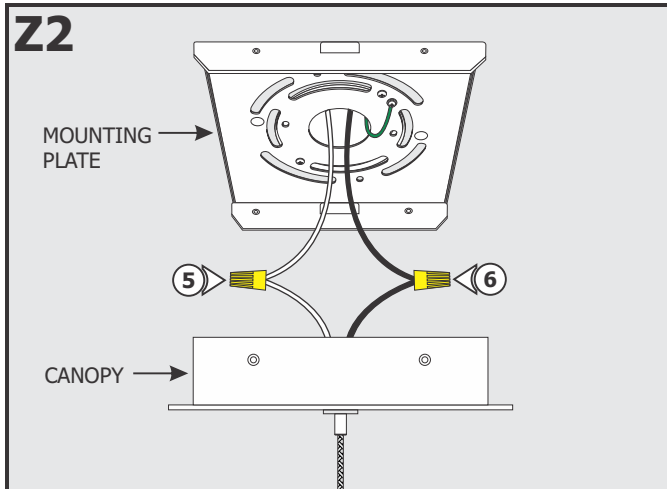
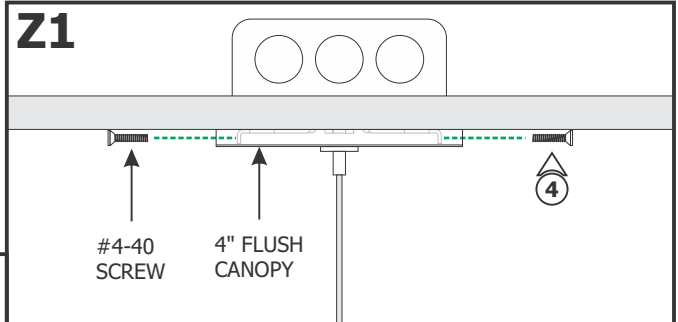

- 5:** Connect the white wire of the transformer to the 120VAC neutral wire with a wire nut.
- 6:** Connect the black wire of the transformer to the 120VAC line wire with a wire nut.

- 7:** Place all line voltage wires and wire nut connections inside the junction box.

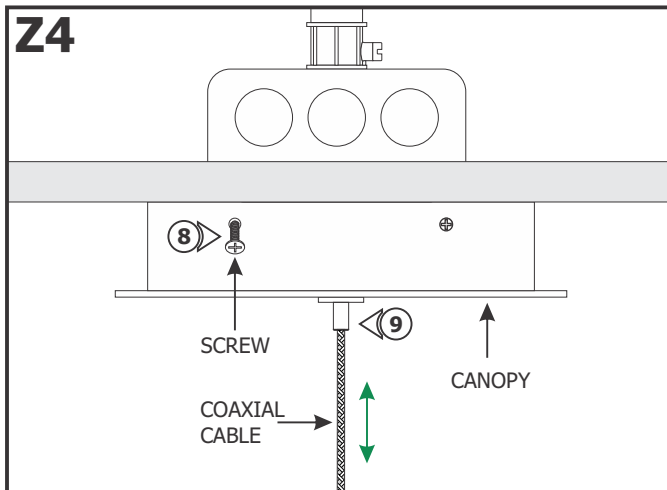
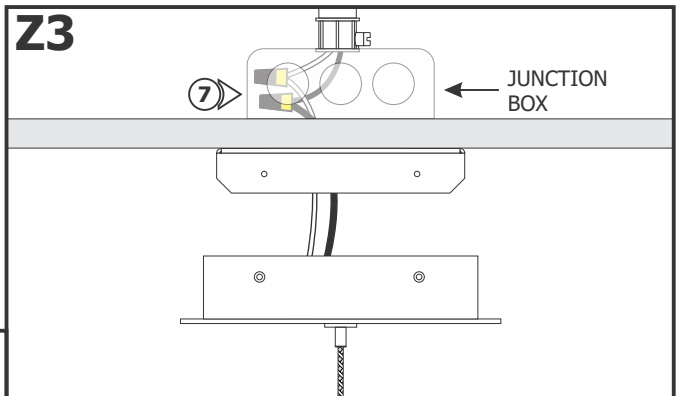

- 8:** Align the canopy holes and secure the canopy in place by tightening the four screws.
- 9:** For fine adjusting the fixture height, push the cord grip to slide the fixture up and down until the desired height is achieved. Release the cord grip to lock the coaxial cable in place.

Section Seven: Multiple Channel Sections

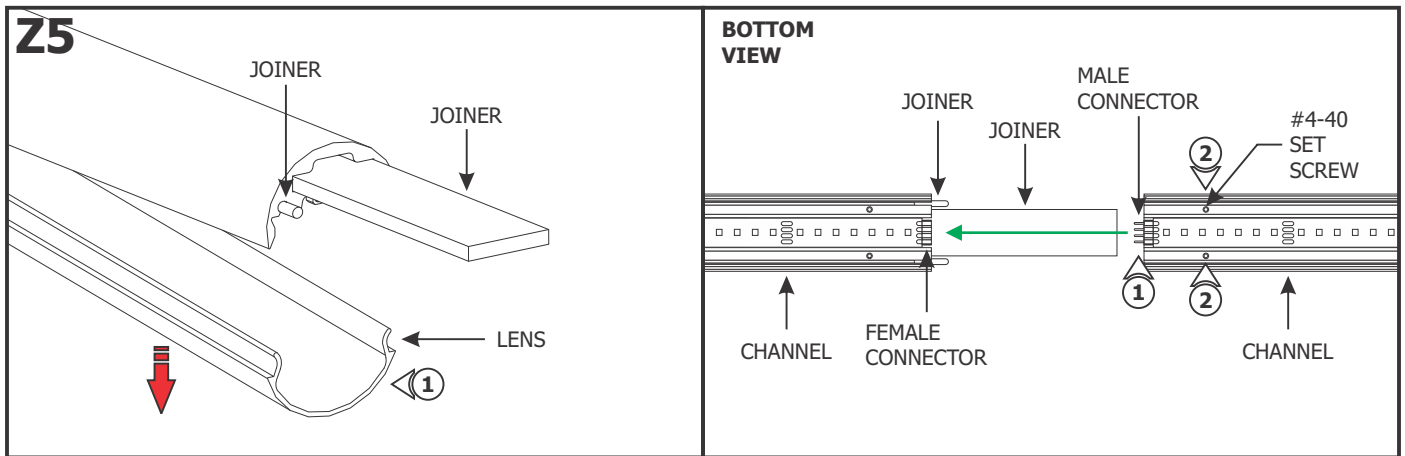

NOTE: If applicable, multiple channels must be installed one by one.

NOTE: Omit this section if the joiner did not come with the fixture depending on the overall fixture length.

- 1:** Lift a section of the lens at the end of the channels where the connectors are visible. Slide the channel over the joiner and ensure the male & female connectors mate properly.
- 2:** Tighten the two #4-40 set screws using a 0.05" Allen wrench.
- 3:** Push the lens back into the channel.
- 4:** Refer to Sections Three or Four to install remaining standoffs and continue to connect additional channels one at a time until the fixture is complete.

Wiring Diagram with 4" Flush Canopy

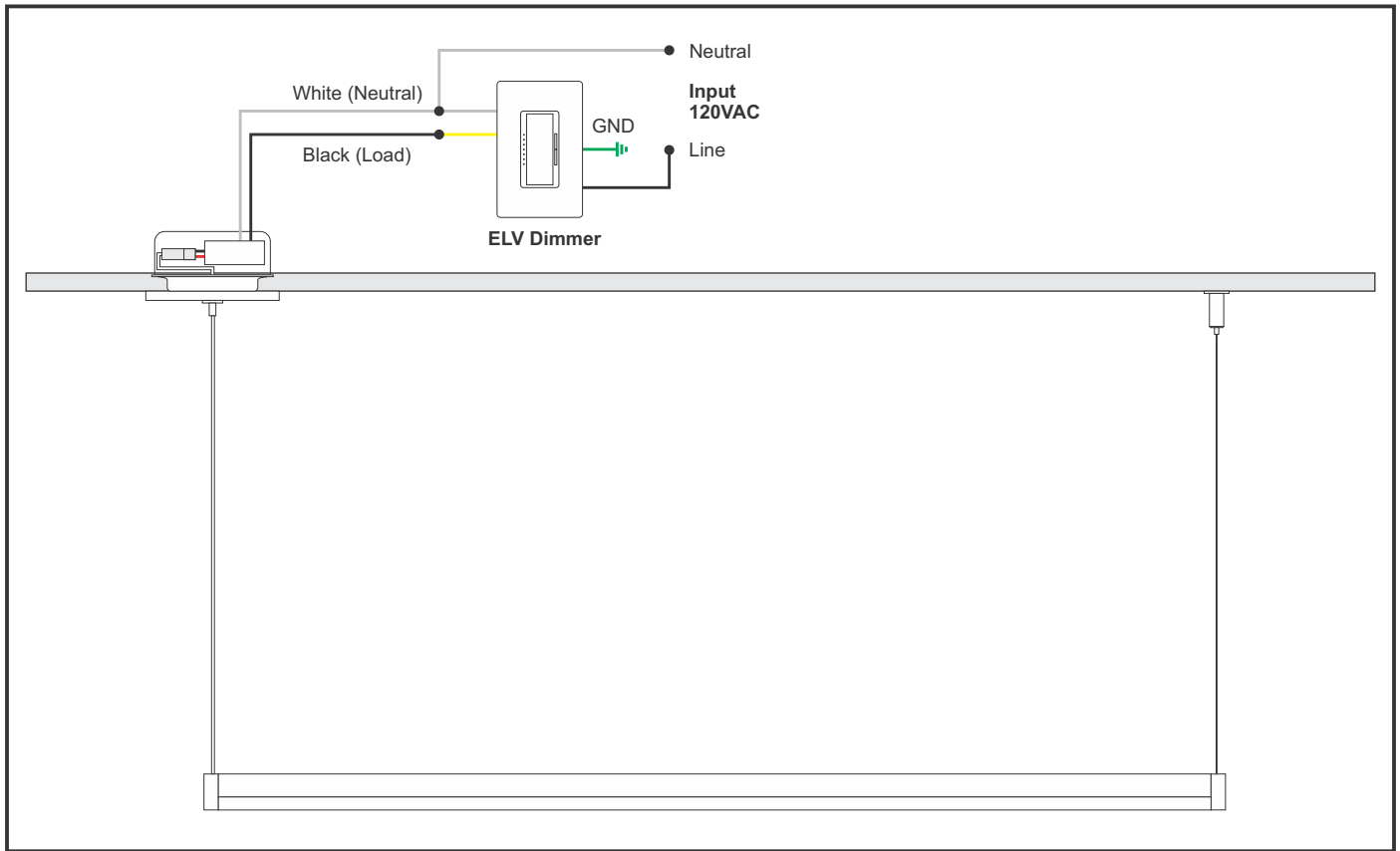

Wiring Diagram with 5" and 6" Surface Mount Canopy

