

DESCRIPTION

Pipeline 1 Suspension Up or Down with power is a linear LED suspension that rotates 360°, allowing you to effortlessly shine the light Up for Indirect Ambiance, Downward to accommodate tasks, or anywhere in between. The sleek tube produces a clean, uninterrupted beam of light through a Diffused White 176° Lens. Highly customizable, the Pipeline 1 Suspension is available in various increments from 12" to 240" (20ft) and nine standard Color Temperatures, including Warm Dim (27D) 2700K or (30D) 3000K that dim down to 2000K. Available in Lumen outputs up to 137 lumens per watt (1313 lumens/foot) using our Designer-grade High CRI (color rendering) LED strip. Choose from Several finishes and optional Black or White Louvers for additional Diffusion. All of our Pipeline 1 products come with a pro-rated five year warranty. For custom finishes and designs, email our design team: design@PureEdgeLighting.com.

Wattages for this fixture are available in the following options:

- 5W - 4.4 watts per foot, lengths up to 240" (20ft)
- 7W - 7.3 watts per foot, lengths up to 156" (13ft)
- 10W - 9.6 watts per foot, lengths up to 120" (10ft)

INSTALLATION

- Includes canopy with 120V/24VDC Electronic Low Voltage LED power supply. For 60 watts (Non-IC), the power supply will fit inside the electrical junction box with a flush 4.6" canopy
- Includes adjustable 12ft coaxial cables (additional aircraft cables included for support when fixture exceeds 72")

FINISHES

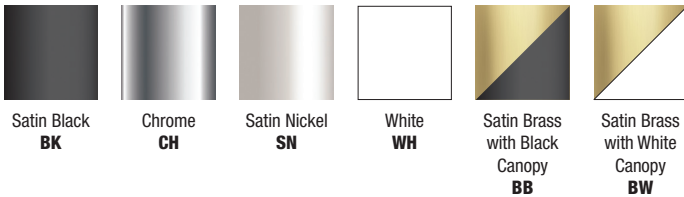

LENS

- Available in a Diffused White Lens with 176° beam spread
- Optional black or white louver

LAMPING

- Choose from 9 color temperatures including Warm Dim
- Warm Dim - 2700K to 2000K (27D) or 3000K to 2000K (30D)
- Lumens - up to 916 lm/ft
- 50,000 Hour Lamp Life

POWER SUPPLY (INCLUDED IN CANOPY):

- 120V input, 24VDC 100 watt
- Electronic Low Voltage LED power supply

CANOPY OPTIONS:

- E - Single End Feed Canopy,
- E2 - Matching Canopies (one is blank)

DIMMERS AND CONTROLS (ORDER SEPARATELY)

- Electronic Low Voltage Dimming (ELV)
- Legrand: Adorne ADTP703TU
- Lutron: Diva DVELV-300P, Skylark SELV-300P, Maestro MAELV-600 and Radio Ra 2

APPLICATIONS

Designed for indoor use only. Ideal environments include: Kitchens, dining rooms, hallways, conference rooms, offices, architectural, retail & general

COMPLIANCE

ETL Listed. Title 24 Compliant. Assembled in America



PIPELINE 1 SUSPENSION IS FULLY ROTATABLE 360°

System	Wattage Per Foot	Canopy	Nominal Size	Color Temperature	Finish
P1SDP	5W	E	240	22K	SN
P1SDP Pipeline 1 Suspension, Diffused Lens without Louver P1SDWP Pipeline 1 Suspension, Diffused Lens with White Louver P1SDBP Pipeline 1 Suspension, Diffused Lens with Black Louver	5W 4.4 Watt (240" max, 20ft) 7W 7.3 Watt (156" max, 13ft) 10W 9.6 Watt (120" max, 10ft)	E End Feed E2 End Feed, 2 Canopies	12-240 Order in 12" increments from 12" to 240".	22K 2200K Amber White 24K 2400K Very Warm White 27K 2700K Incandescent White 27D 2700K Warm Dim (5W only) 30K 3000K Warm White 30D 3000K Warm Dim (5W only) 35K 3500K Neutral White 40K 4000K Cool White 57K 5700K Daylight White	BK Satin Black CH Chrome SN Satin Nickel WH White BB Satin Brass with Black Canopy BW Satin Brass with White Canopy
		*See pg 5 for canopy dimensions	*Maximum shipping length is 120", 84" for Chrome **See length chart for exact dimensions (pg. 3).		

PROJECT		FIXTURE TYPE		DATE	
---------	--	--------------	--	------	--

LAMP DATA Lamp data for Pipeline 1 Suspension Downlight with Power

P1SD																							
176 Degree Diffused White Lens without Louver																							
DESCRIPTION	5W (4.4 Watts)								7W (7.3 Watts)								10W (9.6 Watts)						
WATTS PER FOOT	5W (4.4 Watts)								7W (7.3 Watts)								10W (9.6 Watts)						
COLOR TEMPERATURE	22K	24K	27K	27D*	30K	30D*	35K	40K	57K	22K	24K	27K	30K	35K	40K	57K	22K	24K	27K	30K	35K	40K	57K
LUMENS PER FOOT (lm/ft)	341	378	416	406	454	444	520	565	602	565	627	689	753	863	938	998	743	825	907	991	1134	1233	1313
LUMENS PER WATT (lm/w)	77	86	94	85	103	93	118	129	137	77	86	94	103	118	129	137	77	86	94	103	118	129	137
CRI	85+	90+	95+	95+	95+	95+	85+	84	84	85+	90+	95+	95+	85+	84	84	85+	90+	95+	95+	85+	84	84

P1SDW																							
176 Degree Diffused White Lens with White Louver																							
DESCRIPTION	5w (4.4 watts)								7w (7.3 watts)								10w (9.6 watts)						
WATTS PER FOOT	5w (4.4 watts)								7w (7.3 watts)								10w (9.6 watts)						
COLOR TEMPERATURE	22K	24K	27K	27D*	30K	30D*	35K	40K	57K	22K	24K	27K	30K	35K	40K	57K	22K	24K	27K	30K	35K	40K	57K
LUMENS PER FOOT (lm/ft)	238	264	290	284	317	311	363	395	420	238	264	290	317	363	395	420	519	576	633	692	793	862	917
LUMENS PER WATT (lm/w)	54	60	66	59	72	65	83	90	96	54	60	66	72	83	90	96	54	60	66	72	83	90	96
CRI	85+	90+	95+	95+	95+	95+	85+	84	84	85+	90+	95+	95+	85+	84	84	85+	90+	95+	95+	85+	84	84

P1SDBP																							
176 Degree Diffused White Lens with Black Louver																							
DESCRIPTION	5w (4.4 watts)								7w (7.3 watts)								10w (9.6 watts)						
WATTS PER FOOT	5w (4.4 watts)								7w (7.3 watts)								10w (9.6 watts)						
COLOR TEMPERATURE	22K	24K	27K	27D*	30K	30D*	35K	40K	57K	22K	24K	27K	30K	35K	40K	57K	22K	24K	27K	30K	35K	40K	57K
LUMENS PER FOOT (lm/ft)	136	151	166	163	181	178	208	226	240	226	250	275	301	344	374	399	397	329	362	396	453	492	524
LUMENS PER WATT (lm/w)	31	34	38	34	41	37	47	51	55	31	34	38	41	47	51	55	31	34	38	41	47	51	55
CRI	85+	90+	95+	95+	95+	95+	85+	84	84	85+	90+	95+	95+	85+	84	84	85+	90+	95+	95+	85+	84	84

*27D, 30D - Warm Dim (4.8 Watts)

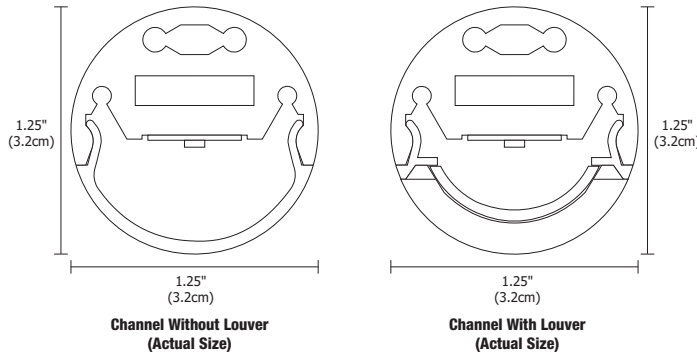

BEAM SPREAD CHART
P1SDP 3000K 5 Watt 176°

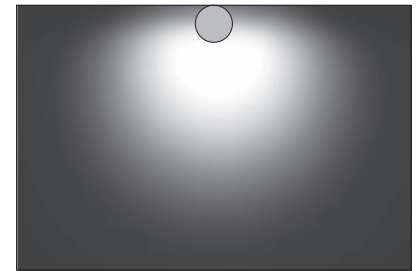

CANDLE POWER DISTRIBUTION 176°

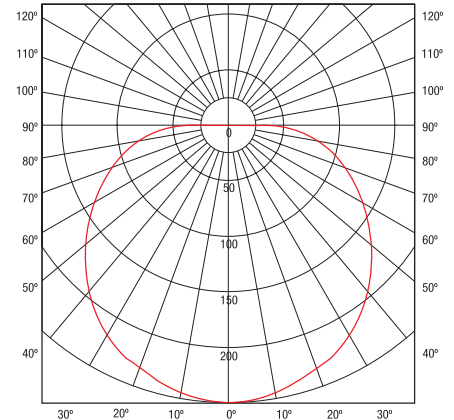

5 Watt 176°	
Distance	Foot Candles
1'	139
1.5'	92
2'	69
3'	45
4'	32
5'	24
6'	19
7'	15
8'	12

7 Watt 176°	
Distance	Foot Candles
1'	227
1.5'	152
2'	114
3'	75
4'	54
5'	40
6'	32
7'	25
8'	21

10 Watt 176°	
Distance	Foot Candles
1'	256
1.5'	172
2'	127
3'	83
4'	60
5'	45
6'	36
7'	28
8'	23

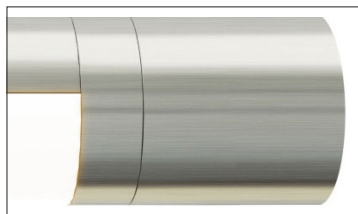

DIFFUSED WHITE LENS

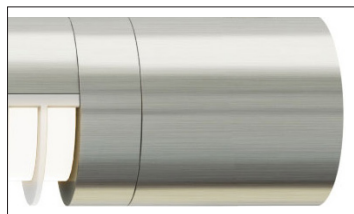

DIFFUSED WHITE LENS WITH WHITE LOUVER

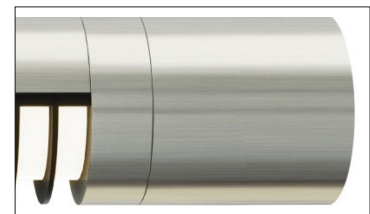

DIFFUSED WHITE LENS WITH BLACK LOUVER

PROJECT		FIXTURE TYPE		DATE	
---------	--	--------------	--	------	--

PIPELINE 1

SUSPENSION UP OR DOWN WITH POWER - END FEED

LENGTH CHART Actual lengths for Pipeline 1 Suspension Up/Down with Power—End Feed

22K, 24K, 27K, 30K, 35K, 40K & 57K														
Nominal Length (Inches)	Actual Length (Inches)	Actual Length (Chrome)	Total Wattage (5W)	Total Lumens 3000K (5W)	Total Lumens White Louver (5W)	Total Lumens Black Louver (5W)	Total Wattage (7W)	Total Lumens 3000K (7W)	Total Lumens White Louver (7W)	Total Lumens Black Louver (7W)	Total Wattage (10W)	Total Lumens 3000K (10W)	Total Lumens White Louver (10W)	Total Lumens Black Louver (10W)
12	14.5	14.5	5	463	324	185	8	670	469	268	10	771	540	309
24	26.5	26.5	10	926	648	370	15	1340	938	536	20	1542	1080	618
36	38.5	38.5	15	1389	972	555	23	2010	1407	804	29	2313	1620	927
48	50.5	50.5	20	1852	1296	740	30	2680	1876	1072	39	3084	2160	1236
60	62.5	62.5	25	2315	1620	925	38	3350	2345	1340	48	3855	2700	1545
72	74.5	74.5	30	2778	1944	1110	45	4020	2814	1608	58	4626	3240	1854
84	86.5	86.5	35	3241	2268	1295	53	4690	3283	1876	68	5397	3780	2163
96	98.5	98.9	40	3704	2592	1480	60	5360	3752	2144	77	6168	4320	2472
108	110.5	110.9	45	4167	2916	1665	68	6030	4221	2412	87	6939	4860	2781
120	122.5	122.9	50	4630	3240	1850	75	6700	4690	2680	96	7710	5400	3090

*84 inches is maximum shipping length for Chrome.

WARM DIM (27D & 30D)									
Nominal Length (Inches)	Actual Length (Inches)	Nominal Length (Feet)	Total Wattage (5W)	Total Lumens 3000K (5W)	Total Lumens White Louver (5W)	Total Lumens Black Louver (5W)	Total Lumens 2700D (5W)	Total Lumens White Louver (5W)	Total Lumens Black Louver (5W)
12	14.5	1	5	472	331	207	432	303	190
24	26.5	2	10	944	662	414	864	606	380
36	38.5	3	15	1416	993	621	1296	909	570
48	50.5	4	20	1888	1324	828	1728	1212	760
60	62.5	5	25	2360	1655	1035	2160	1515	950
72	74.5	6	30	2832	1986	1242	2592	1818	1140
84	86.5	7	35	3304	2317	1449	3024	2121	1330
96	98.5	8	40	3776	2648	1656	3456	2424	1520
108	110.5	9	45	4248	2979	1863	3888	2727	1710
120	122.5	10	50	4720	3310	2070	4320	3030	1900

*84 inches is maximum shipping length for Chrome.

PROJECT		FIXTURE TYPE		DATE	
---------	--	--------------	--	------	--

Accessories: Accessories for Pipeline 1 Suspension Up/Down with Power - End Feed

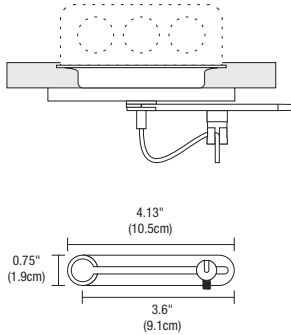
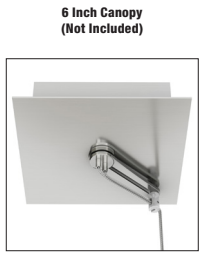

CHANNEL SUSPENSION ADJUSTABLE SWAG BAR & HOOK

The Adjustable Swag Bar and Hook allows a cable to form a straight connection to the channel when the Power Canopy is not located directly above the fixture. Use when you have two or more power supplies and canopies on the same fixture run. The Adjustable Swag Hook is compatible with the 2R, 2S, 4S, 4R, 5S and 6S Power Canopies (Canopy not included).

Product	Type	Finish
CS	ADJ-SWAG	SN
CS Channel Suspension	ADJ-SWAG Adjustable Swag Hook for Static White ADJ-DP-SWAG Dual Post Adjustable Swag Hook for 2K4K & RGB	SN Satin Nickel

CHANNEL SUSPENSION SWAG HOOK

The clear plastic Swag Hook extends a cable from an electrical box that is not located directly above desired fixture location.

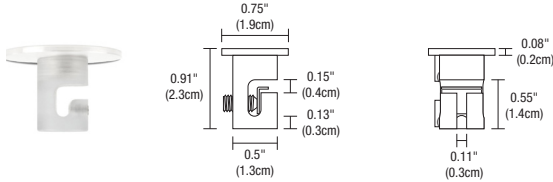

System	Type
CS	SWAG
CS Channel Suspension	SWAG Swag Hook

PIPELINE SUSPENSION ADJUSTABLE T-BAR CLIP

Pipeline Suspension Adjustable T-Bar Clip mounts to T-Bar grid ceiling. Available in Satin Nickel hardware as adjustable power and non-power versions.

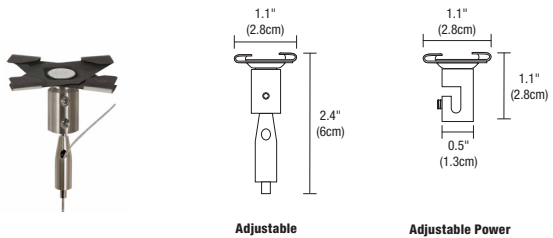

Product	Type	Options	Finish
CS	TBAR	A	W
CS Channel Suspension	TBAR 9/16" and 15/16"	A Adjustable AP Adjustable Power	W White BK Satin Black

PROJECT	FIXTURE TYPE	DATE
---------	--------------	------

Drawings: Canopy and Channel Sizes for the Pipeline 1 Suspension Downlight with Power - End Feed

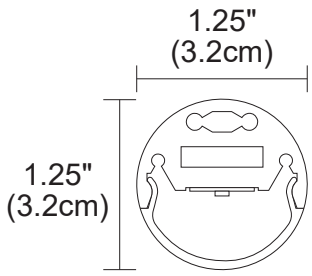
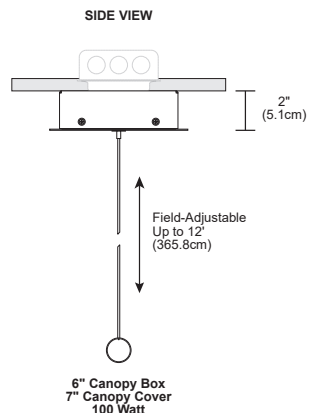
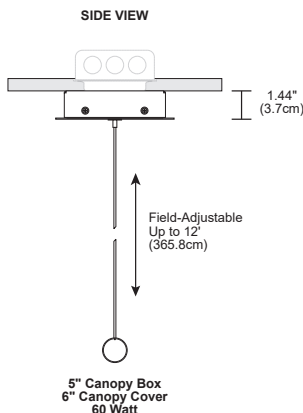
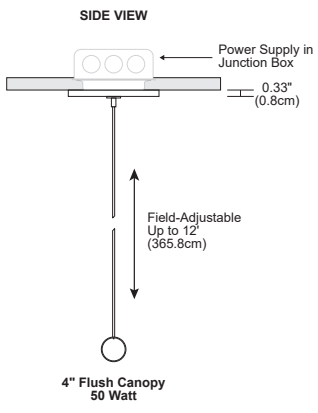
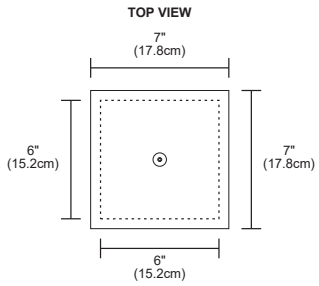
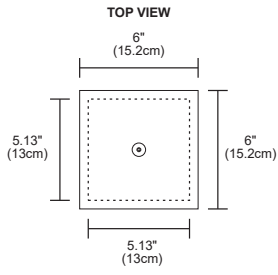
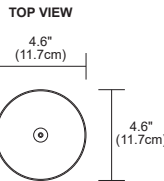
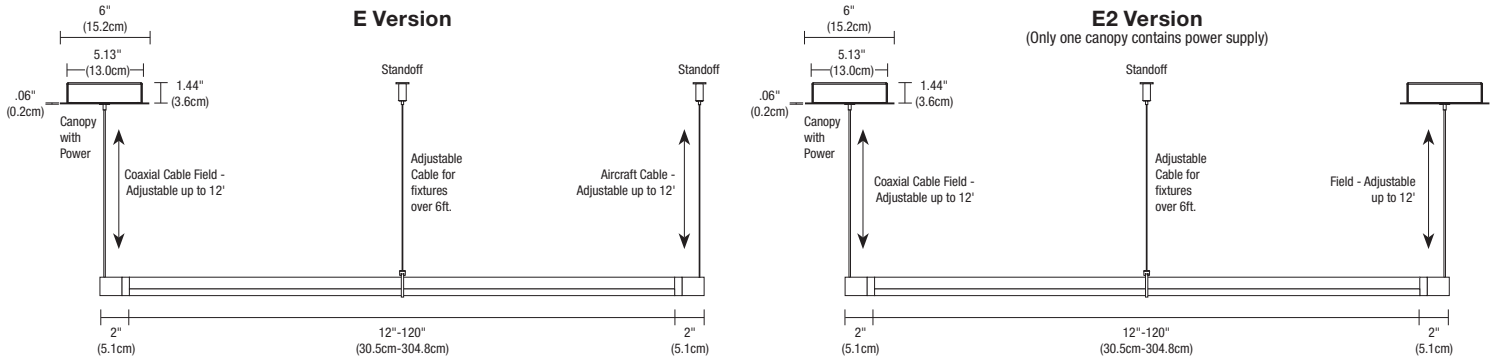

CANOPY CHART			
VERSION	4" FLUSH CANOPY (50 WATT)	5" SURFACE MOUNT CANOPY (60 WATT)	6" SURFACE MOUNT CANOPY (100 WATT)
5W Lengths (5.4W)	Up to 108"	120"	240"
7W Lengths (7.5W)	Up to 72"	84" - 96"	108"-120"

PROJECT	FIXTURE TYPE	DATE
---------	--------------	------

Wiring Diagram: Wiring diagram for an ELV Dimmer

Application: ELV dimming for Pipeline 1 Suspension Up or Down with Power - End Feed

Dimming: Dimmable with ELV dimmer: Legrand, Adorne ADTP703TU;
Lutron: Diva DVELV-300P, Skylark SELV-300P, Maestro MAELV-600 and Radio Ra 2

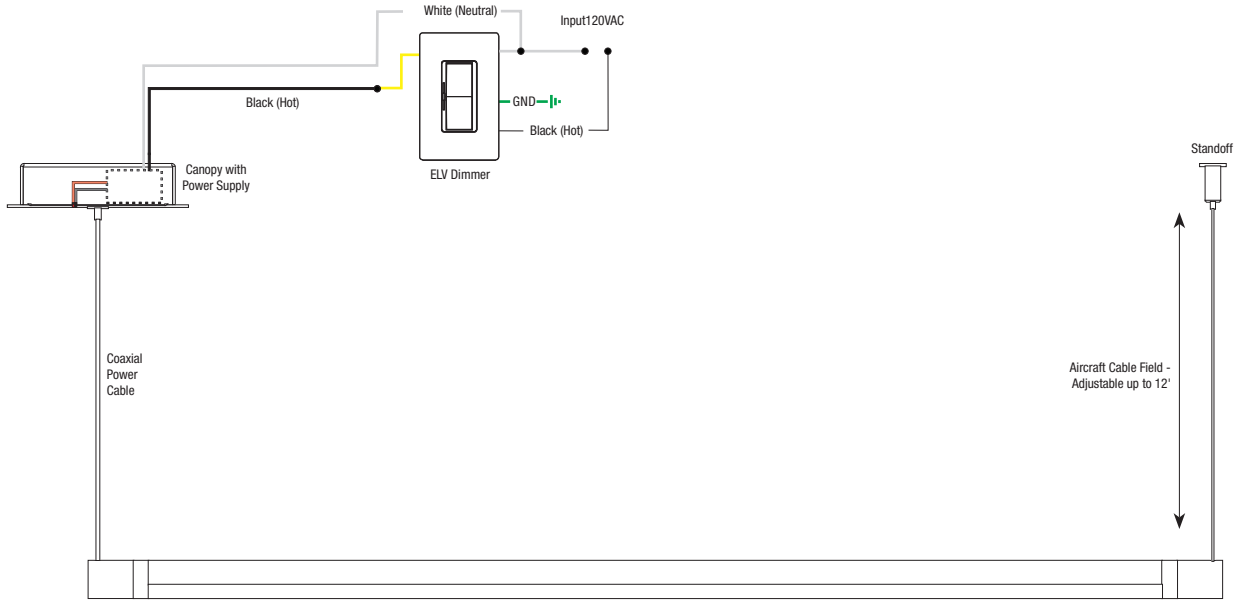

Up to 20ft long. Additional adjustable cable supports provided for fixtures over 6ft

PROJECT	FIXTURE TYPE	DATE
---------	--------------	------

SUSPENSION TM30 DATA

SUSPENSION UP OR DOWN WITH POWER - END FEED

TM-30-15 DATA: The data below is for SS2C, SS5C, SS7C, and SS10C bare LED Soft Strips. Consistent color temperatures throughout a single strip and among multiple strips is possible through a 3 phase binning process in which each order is inspected with a color meter to ensure uniformity.

2200K | Rf: 83.9 | Rg: 94.9
Color Vector Graphic

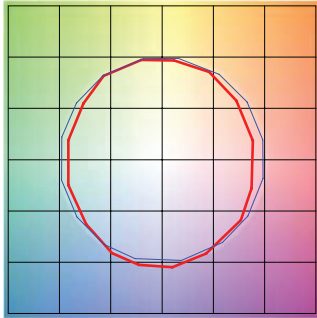

■ Test ■ Reference

		GRAPHIC SHIFTS %	
HUE BIN	Rf	CHROMA	HUE
1	78.8	-9.5%	1.3%
2	80.7	-7.8%	6.7%
3	78.2	-3.3%	9.4%
4	89.7	-2.8%	3.6%
5	93.2	-0.8%	2.6%
6	93.0	-0.6%	-0.7%
7	87.7	-5.9%	-3.5%
8	89.2	-6.8%	1.9%
9	83.4	-5.6%	6.0%
10	79.3	-3.7%	10.8%
11	81.4	2.9%	11.1%
12	84.9	5.3%	4.9%
13	88.1	4.9%	-10.1%
14	68.1	0.1%	-19.5%
15	86.0	-3.3%	-7.3%
16	76.4	-8.9%	-11.7%

2400K | Rf: 91.2 | Rg: 96.8
Color Vector Graphic

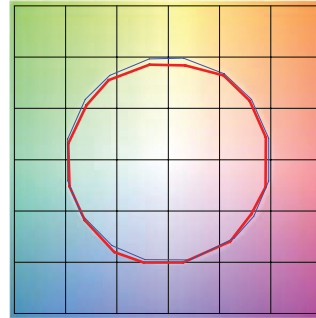

■ Test ■ Reference

		GRAPHIC SHIFTS %	
HUE BIN	Rf	CHROMA	HUE
1	92.0	-2.4%	1.5%
2	94.7	-2.1%	0.0%
3	95.4	-1.9%	-0.1%
4	88.7	-6.7%	-3.1%
5	92.8	-5.6%	1.0%
6	92.7	-3.4%	3.4%
7	89.9	-4.3%	4.1%
8	92.4	-1.4%	4.4%
9	89.0	-0.6%	5.8%
10	88.9	0.4%	6.2%
11	89.7	4.0%	5.4%
12	92.6	3.0%	-0.7%
13	90.9	1.1%	-7.0%
14	89.9	0.5%	-5.8%
15	92.1	-3.2%	0.1%
16	88.9	-1.7%	-6.3%

2700K | Rf: 87.7 | Rg: 96.1
Color Vector Graphic

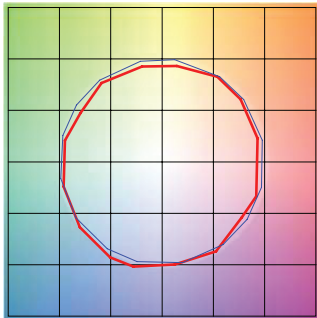

■ Test ■ Reference

		GRAPHIC SHIFTS %	
HUE BIN	Rf	CHROMA	HUE
1	88.0	-4.3%	2.6%
2	91.6	-2.4%	2.0%
3	93.7	-1.4%	1.9%
4	88.9	-5.6%	-3.1%
5	92.3	-5.5%	-0.5%
6	92.9	-3.5%	0.1%
7	84.5	-7.5%	4.6%
8	90.8	-3.0%	4.4%
9	84.5	-1.3%	8.3%
10	83.9	2.0%	9.8%
11	87.2	5.3%	7.1%
12	89.2	5.4%	-2.6%
13	88.7	0.3%	-7.8%
14	86.8	1.7%	-9.3%
15	87.6	-5.4%	-1.3%
16	83.6	-3.3%	-9.5%

3000K | Rf: 88.1 | Rg: 99.7
Color Vector Graphic

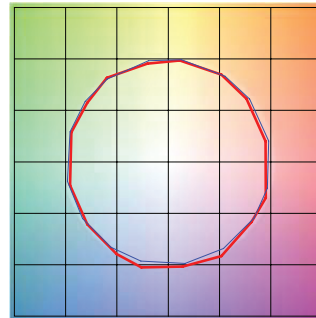

■ Test ■ Reference

		GRAPHIC SHIFTS %	
HUE BIN	Rf	CHROMA	HUE
1	92.5	-3.1%	0.3%
2	93.3	-2.3%	1.9%
3	90.9	-0.8%	3.9%
4	94.3	-1.1%	1.4%
5	92.5	-2.6%	1.5%
6	96.4	1.2%	-0.3%
7	92.6	-2.5%	-0.0%
8	96.9	-1.4%	0.2%
9	92.3	-1.8%	4.3%
10	86.6	-0.7%	7.0%
11	86.5	2.4%	8.2%
12	89.8	5.9%	1.7%
13	93.9	2.6%	-2.7%
14	89.4	5.1%	-5.8%
15	90.1	-0.1%	-4.7%
16	86.5	0.3%	-9.7%

3500K | Rf: 86.1 | Rg: 95.5
Color Vector Graphic

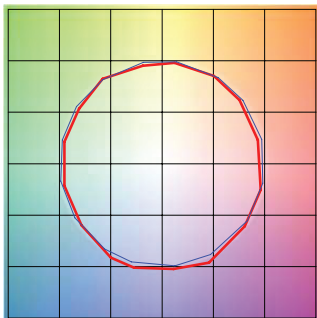

■ Test ■ Reference

		GRAPHIC SHIFTS %	
HUE BIN	Rf	CHROMA	HUE
1	90.8	-3.8%	0.3%
2	92.3	-2.8%	2.1%
3	89.7	-1.0%	4.3%
4	92.6	-1.4%	1.7%
5	91.8	-3.1%	1.3%
6	96.2	0.8%	-0.4%
7	92.9	-3.2%	0.2%
8	94.3	-2.5%	1.5%
9	90.4	-2.5%	5.2%
10	84.3	-1.4%	9.5%
11	83.1	3.5%	9.8%
12	88.2	4.8%	3.4%
13	94.0	2.7%	-2.0%
14	88.7	5.9%	-5.8%
15	88.7	0.7%	-5.9%
16	86.8	-0.7%	-6.7%

4000K | Rf: 87.6 | Rg: 96.8
Color Vector Graphic

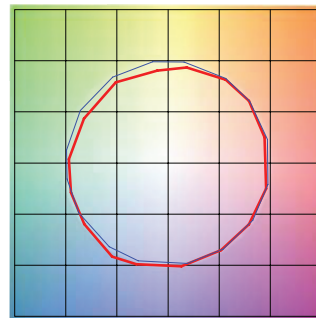

■ Test ■ Reference

		GRAPHIC SHIFTS %	
HUE BIN	Rf	CHROMA	HUE
1	88.9	-2.4%	2.5%
2	93.3	-0.4%	0.8%
3	94.8	-1.0%	-0.6%
4	87.9	-4.9%	-3.6%
5	85.3	-9.4%	-2.6%
6	90.2	-6.0%	0.2%
7	85.3	-7.6%	4.6%
8	83.7	-4.1%	8.2%
9	79.5	-1.1%	13.8%
10	78.6	1.5%	12.1%
11	83.5	6.4%	7.8%
12	90.9	3.6%	-1.1%
13	88.3	1.7%	-6.3%
14	91.9	-0.4%	-2.2%
15	84.5	-0.9%	-5.5%
16	84.7	-1.1%	-4.4%

PROJECT	FIXTURE TYPE	DATE
---------	--------------	------

SUSPENSION TM30 DATA

SUSPENSION UP OR DOWN WITH POWER - END FEED

TM-30-15 DATA: The data below is for SS5C and SS7C bare LED Soft Strips. Consistent color temperatures throughout a single strip and among multiple strips is possible through a 3 phase binning process in which each order is inspected with a color meter to ensure uniformity.

5700K | Rf: 80.3 | Rg: 91.5

Color Vector Graphic

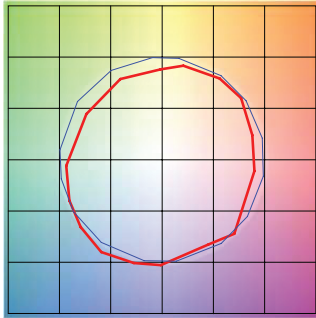

■ Test ■ Reference

GRAPHIC SHIFTS %			
HUE BIN	Rf	CHROMA	HUE
1	75.4	-8.9%	4.7%
2	87.5	-2.6%	4.6%
3	90.7	-3.0%	-0.5%
4	83.2	-6.0%	-5.7%
5	76.2	-12.9%	-5.3%
6	81.4	-11.9%	-2.6%
7	74.8	-14.0%	5.1%
8	69.0	-9.0%	14.1%
9	72.6	-3.6%	22.2%
10	71.4	2.7%	16.1%
11	81.3	7.9%	5.3%
12	83.6	4.1%	-9.4%
13	78.4	0.7%	-15.3%
14	77.7	-6.2%	-11.0%
15	68.8	-1.3%	-21.2%
16	80.8	-9.6%	3.3%

2700D | Rf: 89.5 | Rg: 100.8

Color Vector Graphic

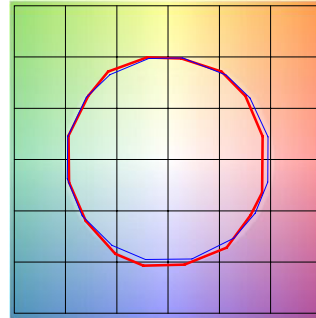

■ Test ■ Reference

GRAPHIC SHIFTS %			
HUE BIN	Rf	CHROMA	HUE
1	88.8	-5.1%	1.4%
2	89.8	-2.7%	4.1%
3	87.2	0.3%	5.9%
4	92.3	-0.9%	1.0%
5	93.3	1.5%	1.7%
6	92.4	3.6%	-0.2%
7	92.2	-0.9%	-2.4%
8	96.7	-0.4%	-1.1%
9	92.3	-1.2%	3.7%
10	88.9	-0.0%	6.1%
11	86.4	5.1%	7.4%
12	88.2	6.3%	-0.9%
13	87.2	3.8%	-8.1%
14	84.2	3.8%	-11.0%
15	89.8	-2.6%	-4.3%
16	82.7	-3.4%	-11.1%

3000D | Rf: 89.8 | Rg: 101.4

Color Vector Graphic

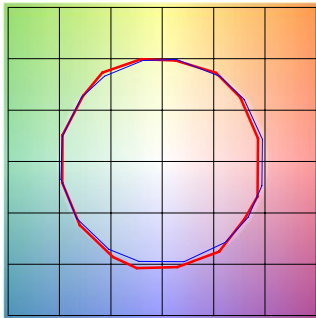

■ Test ■ Reference

GRAPHIC SHIFTS %			
HUE BIN	Rf	CHROMA	HUE
1	90.2	-4.2%	1.5%
2	90.9	-2.0%	3.7%
3	87.9	0.8%	5.5%
4	92.1	-0.9%	0.6%
5	93.0	1.5%	1.6%
6	92.2	3.9%	-0.2%
7	92.1	-0.3%	-2.0%
8	96.7	0.0%	-1.2%
9	92.5	-0.6%	3.7%
10	88.3	1.1%	7.0%
11	87.2	4.1%	7.4%
12	87.2	6.7%	-1.0%
13	88.2	3.8%	-7.2%
14	85.3	4.3%	-9.9%
15	90.9	-2.2%	-3.6%
16	83.4	-2.2%	-11.2%

PROJECT	FIXTURE TYPE	DATE
---------	--------------	------