



1718 W. Fullerton Chicago, IL 60614  
 Ph: 773.770.1195 • Fax: 773.935.5613  
 www.PureEdgeLighting.com • info@PureEdgeLighting.com  
 © 2016 PureEdge Lighting. All Rights Reserved.

## Installation Instructions for **96 Watt 24 Volt DC Power Supply In-Wall Universal Dimming**



### SAVE THESE INSTRUCTIONS!

#### GENERAL INFORMATION

- **RISK OF FIRE:** This product must be installed by a qualified electrician. Turn the power to the electrical box off during installation. Read the "Important Safety Instructions " before installation.
- **NOTE:** To avoid overheating the power supply, install it in a ventilated remote location where air flows. Maintain proper spacing among power supplies when multiple power supplies are installed in the same remote location.
- This product is not suitable for wet locations. It is approved for the use at any height above the finished floor.
- A typical installation is shown. Specific installation must be in accordance with the local electrical codes.
- **TO REDUCE RISK OF FIRE,** it is important to wire the power supply for the system as described in this installation instruction.
- Load the power supply to **MAXIMUM 96** Watts.
- For multiple parallel runs, do not exceed 32' total length.

#### IMPORTANT SAFETY INSTRUCTIONS

- Do not install this power supply in a wet location.
- To reduce the risk of the system overheating and possibly causing a fire, make sure all the connections are tight.
- Do not install \*LED fixture closer than three inches or as specified in the \*LED fixture installation instructions to curtains or similarly combustible materials. Keep insulation at least 3" away from the enclosure.
- Turn the electrical power off before modifying the lighting system in any way.
- The system is "ETL" listed for USA and Canada only when all the products used are supplied by Edge Lighting.
- \* See LED fixture installation instructions for proper placement.

### Install the Power Supply Kit

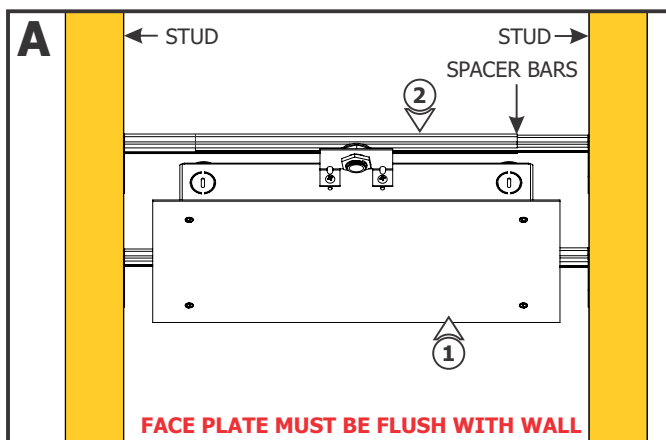

- 1:** Ensure that front plate of power supply box is flush with wall.
- 2:** Use sliding spacers to mount power supply box between studs.

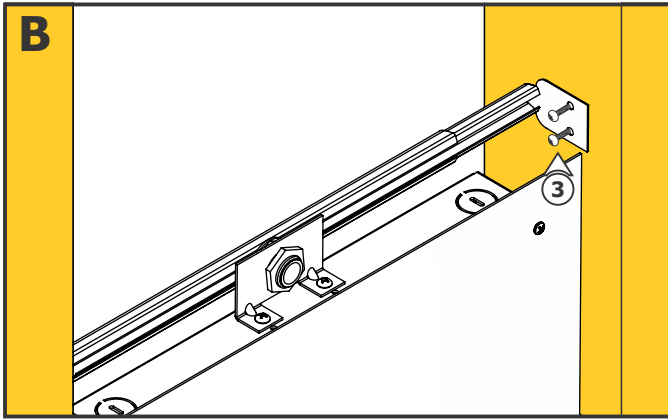

**3:** Screw spacer bars to studs, ensuring that the front face plate stays flush with wall.

- 4:** Measure the distance from sides of faceplate to floor/ceiling/walls.
- 5:** Mark a rectangle shape on drywall where the junction box opening will be located depending on selected position.
- 6:** Cut out the marked rectangle opening, using a "Dremel Multi-Max" or other appropriate tool.
- 7:** Install & finish drywall.

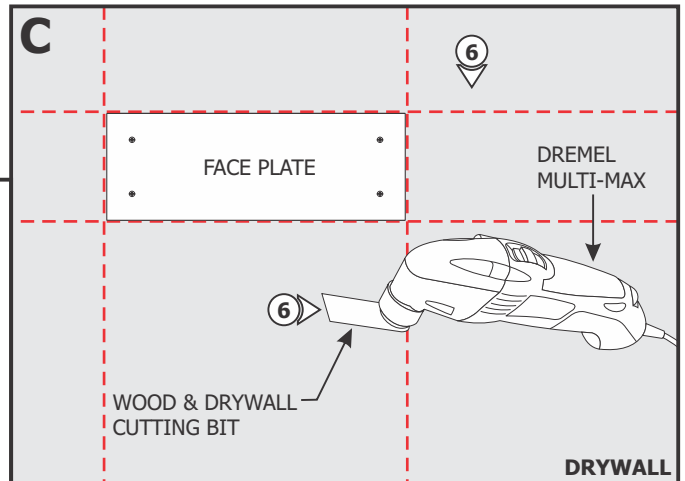

## Install the Power Supply

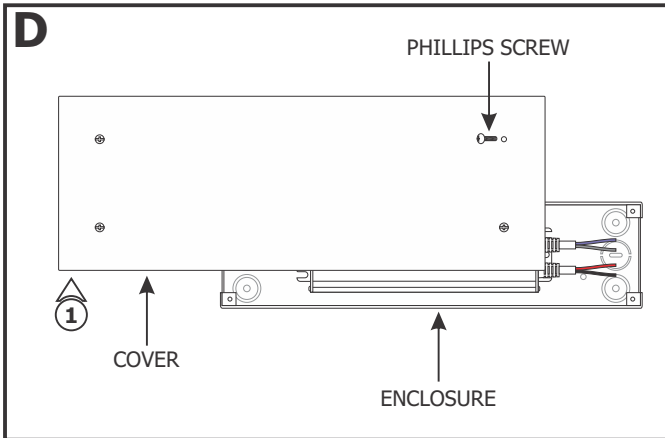

**1:** Loosen and remove the four Phillips screws on the front of the power supply cover to remove the cover from the enclosure.

- NOTE:** Refer to wiring diagrams on page 4. Steps 2 through 13 show typical installation for 0-10V dimmers.
- 2:** Install conduits from the controller, main panel (line voltage) and soft strip or fixture to the power supply enclosure.
  - 3:** Connect the black, white, red, purple and gray controller wires respectively to the black, white, red, purple and gray wires with a wire nut. For three way switching, refer to the instructions provided with the controller.
  - 4:** Run the wires from the controller to the power supply enclosure.

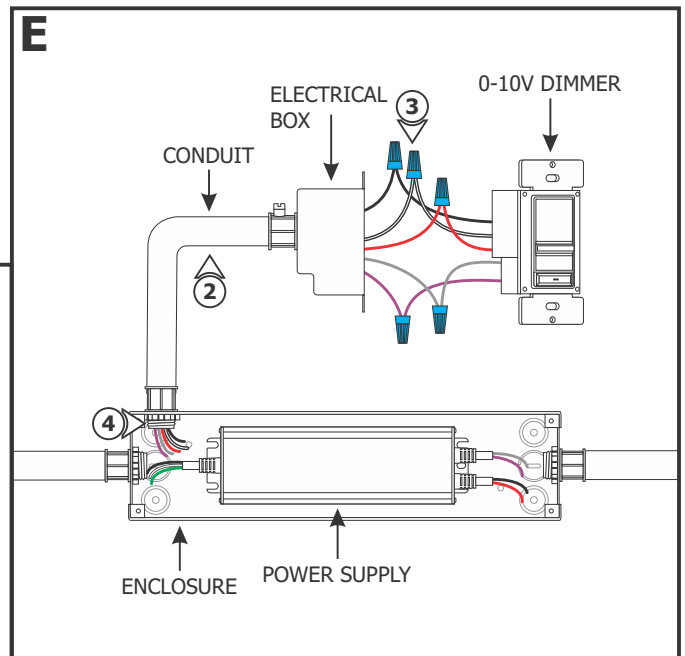

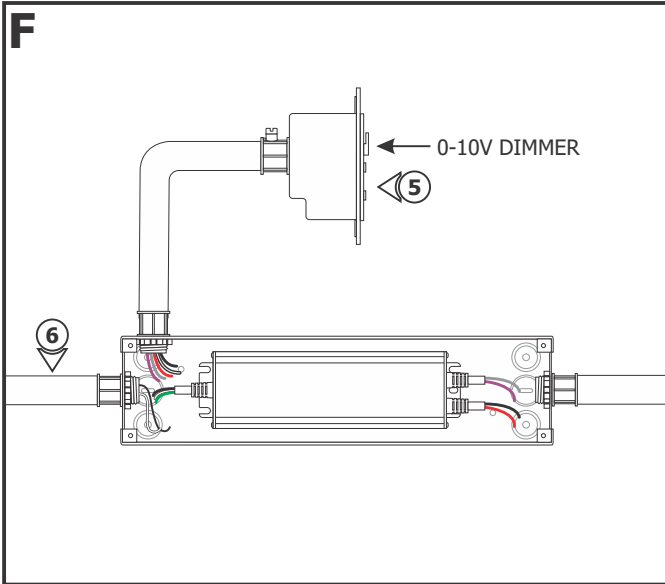

**5:** Secure the controller to the electrical box.

**6:** Run the line voltage power wires from the panel to the power supply enclosure.

**7:** **DO NOT** connect the power wires to the panel at this time.

**8:** Make sure the power supply is grounded in accordance with local electrical codes.

**9:** Connect the black controller wire to the line voltage hot wire with a wire nut.

**10:** Connect the white controller wire to the line voltage neutral wire and white wire of the power supply with a wire nut.

**11:** Connect the red controller wire to the black wire of the power supply with a wire nut.

**NOTE:** For ELV dimming, cap the 0-10V wire ends with wire nuts. The 0-10V wires are not used.

**12:** Connect the gray controller wire to the gray wire of the power supply with a wire nut.

**13:** Connect the purple controller wire to the purple wire of the power supply with a wire nut.

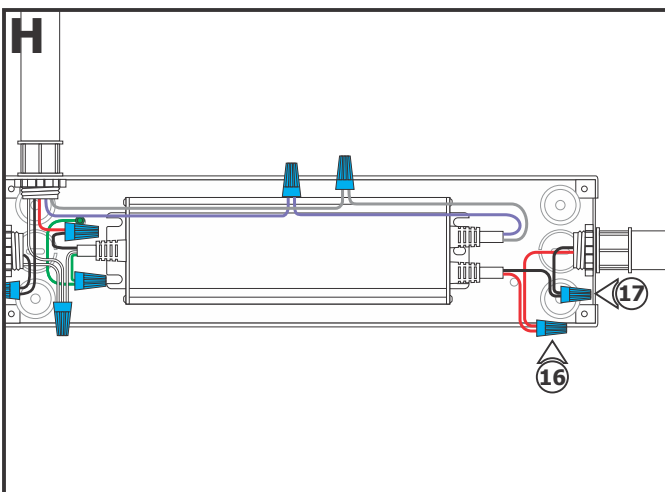
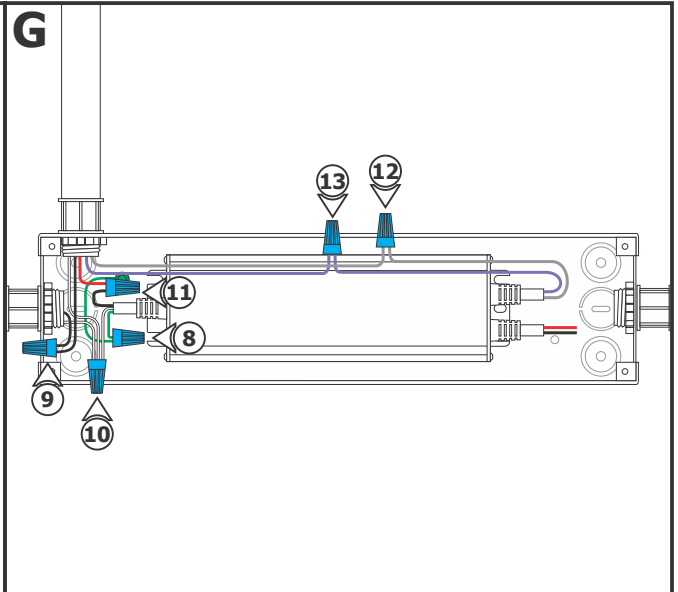

**14:** Use the "Low Voltage Wire Size Chart" on page 4 to determine the proper wire size connecting the power supply to the LED soft strip/fixture.

**15:** Run the proper size red and black wires from the LED soft strip/fixture to the power supply enclosure.

**16:** Connect the red (+24VDC) wire from the power supply to the red wires of the LED soft strip/fixture with a wire nut.

**17:** Connect the black (-24VDC) wire from the power supply to the black wires of the LED soft strip/fixture with a wire nut.

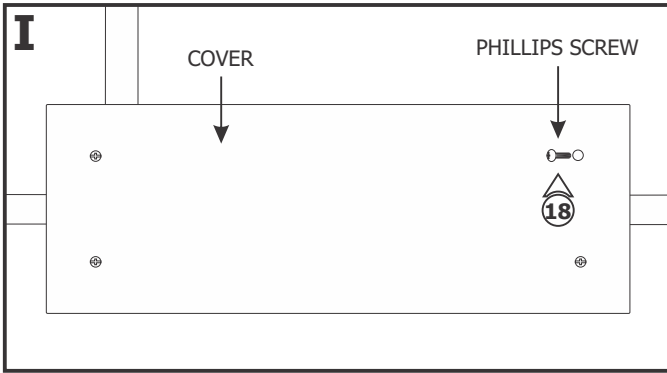

**18:** Replace the power supply cover and secure it by tightening the four Phillips screws.

96W, 24VDC LOW VOLTAGE WIRE SIZE CHART					
3% VOLTAGE DROP	WIRE LENGTH IN FT	UP TO 33FT	34FT - 52FT	53FT - 86FT	87FT - 130FT
	WIRE SIZE	14 AWG	12 AWG	10 AWG	8 AWG
	VOLTAGE AT END OF THE WIRE	23.28 VDC	23.29 VDC	23.28 VDC	23.28 VDC

## Wiring Diagrams

### General ELV Wiring

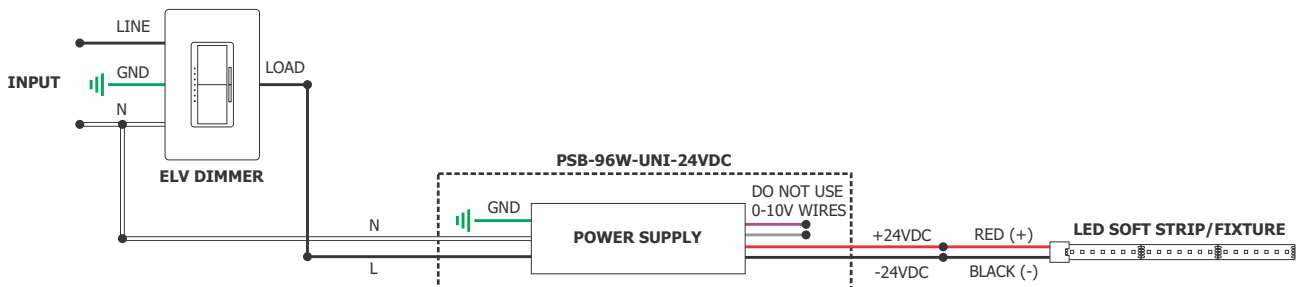

### General 0-10V Wiring

