



1718 W. Fullerton Chicago, IL 60614
 Ph: 773.770.1195 • Fax: 773.935.5613
 www.PureEdgeLighting.com • info@PureEdgeLighting.com
 © 2016 PureEdge Lighting. All Rights Reserved.

Installation Instructions for **SS7C Commercial Soft Strip LED 7W/ft 24 Volt** and **SS10C Commercial 9.6W/ft 24 Volt**

SS7C-24V- SS10C-24V-

IMPORTANT INFORMATION

ETL LISTED

Intertek
3028534

- Conforms to UL STD 1598 & UL STD 2108 Certified to CAN/CSA STD C22.2 NO 250.0
- Suitable for Under-Cabinet Mount
- Dry Location Only
- Use Only With Class 2 Power Unit
- Peut être fixé Sous Une Armoire
- Pour Emplacements Secs Seulement
- Utiliser Seulement Avec Classe 2 Unité d'alimentation électrique



SAVE THESE INSTRUCTIONS!

Section One: Prepare the LED Soft Strip

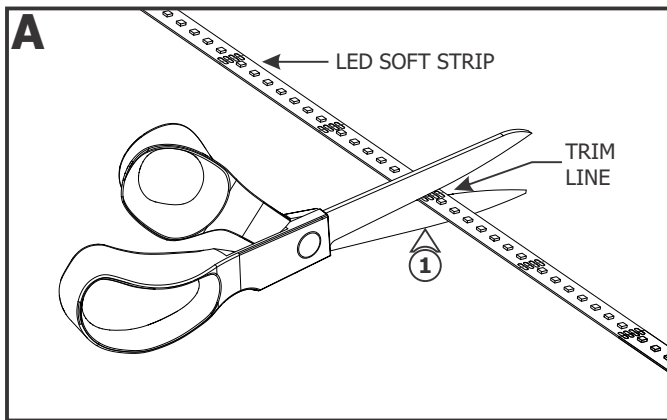

1: If necessary trim the LED strip at the marked line above the contact (every 2.4" apart) with a sharp scissor to fit the design.

NOTE: Do not trim the strip over the sections that are joined together by soldering. The soldered contact will not connect to the Snap & Light connector easily.

NOTE: Do not trim the strip at unmarked sections which may cause that section of the strip not to light up.

2: Place the LED Soft Strip on a flat, stable surface. Using a utility knife, carefully scrape the protective coating from the contacts.

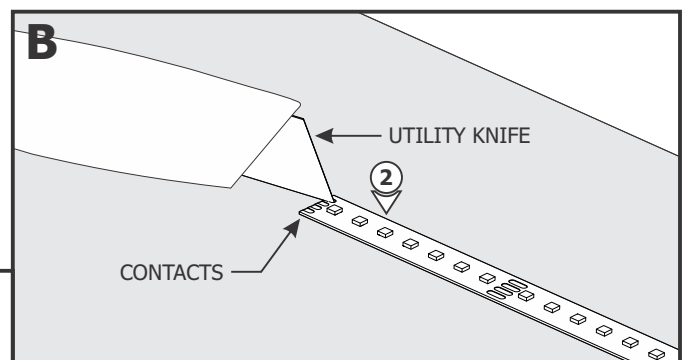

Section Two: Install the Soft Strip

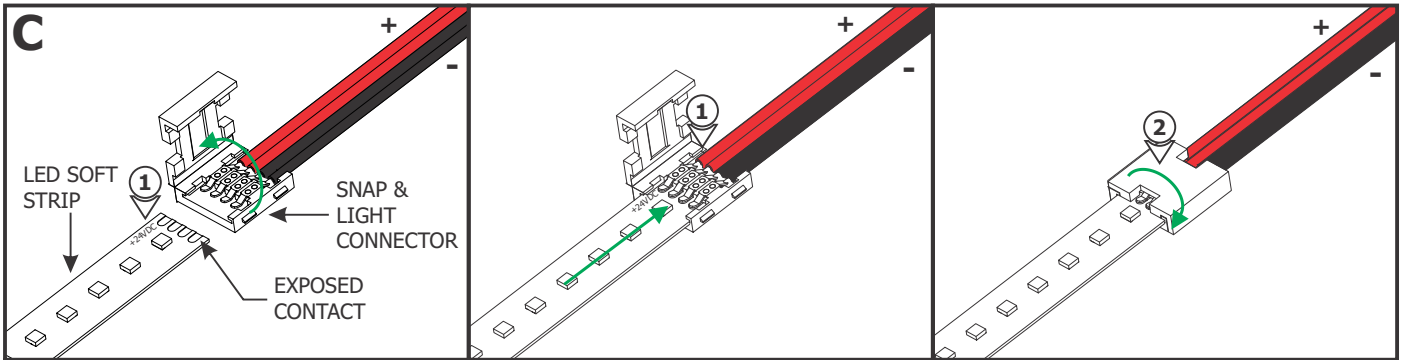

- 1:** Align the +24VDC marking on the soft strip with the red wires of the Snap & Light connector. Insert the exposed contact at the end of the LED strip under the Snap & Light contacts ensuring that the strip contacts are aligned and covered under the connector contacts.
- 2:** Close the Snap & Light cover and ensure it snaps securely into place.

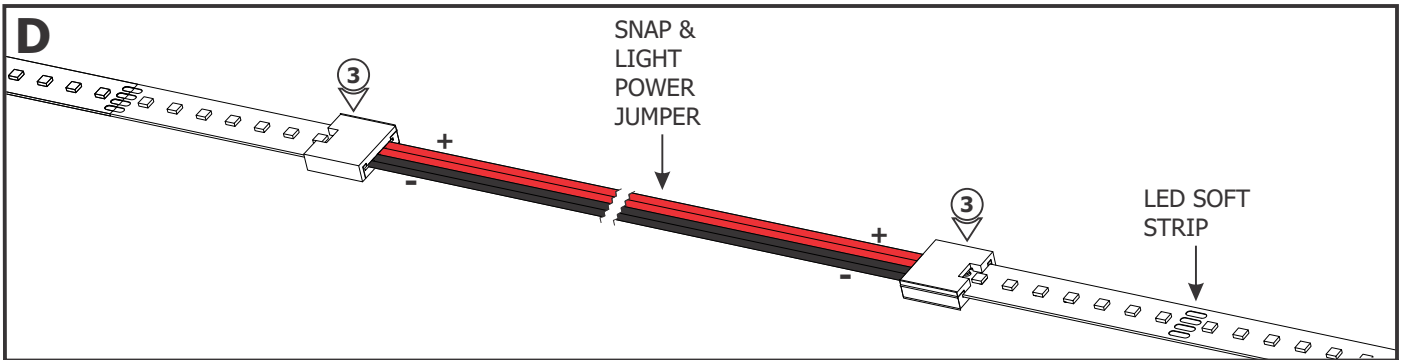

- 3:** When using the Snap & Light power jumper with another soft strip, follow the steps on Section One; steps 1 and 2 on Section Two.

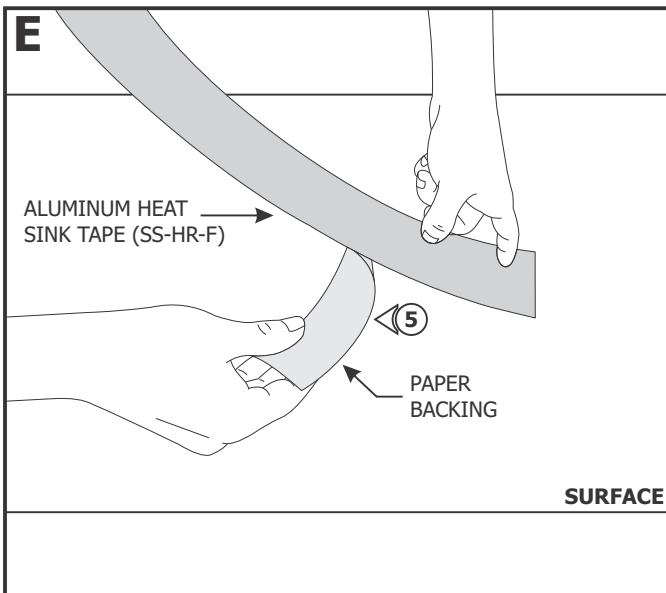

NOTE: Use Aluminum Heat Sink Tape to extend potential LED life expectancy.

NOTE: The soft strip LEDs are rated for 40,000 hours when using the aluminum heat sink tape.

NOTE: The adhesive tape of the aluminum heat sink needs to be affixed to smooth, clean surfaces (2" minimum). The tape adhesive does not work well with porous, textured, or unfinished wood surfaces. For these surfaces, soft strip clips are required (sold separately).

- 4:** Clean the surface thoroughly where the LED strip will be installed.

- 5:** Remove the backing from the Aluminum Heat Sink Tape and firmly press down onto the surface where the LED strip will be mounted.

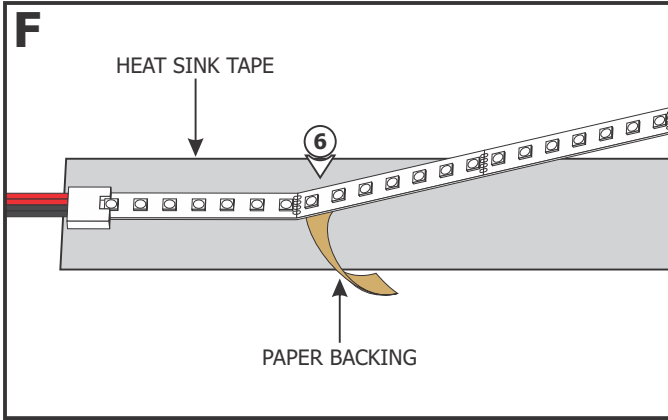

6: Carefully remove the backing from the LED soft strip, make sure not to remove the tape from the soft strip. Firmly press down the adhesive portion of the soft strip onto the heat sink tape while removing the rest of the backing, making sure there are no air bubbles that can cause surface irregularities.

7: Trim the other end of the Snap & Light connector when it is used as the power cord. Refer to the wiring diagram on page 3 and the instructions provided with the power supply to complete the installation.

NOTE: SS7C soft strip consumes on average 7 Watt per foot.

NOTE: SS10C soft strip consumes on average 9.6 Watt per foot.

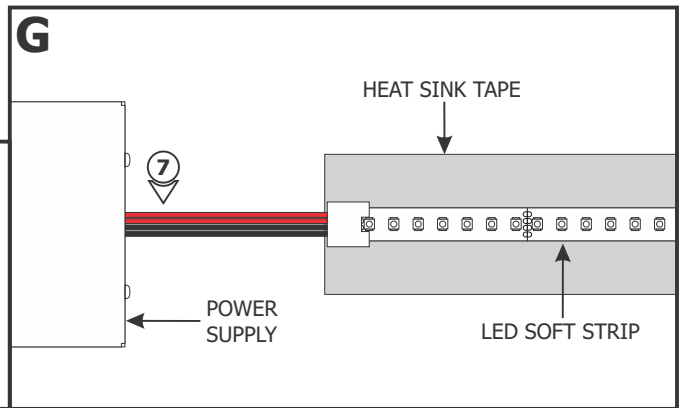

Wiring Diagram

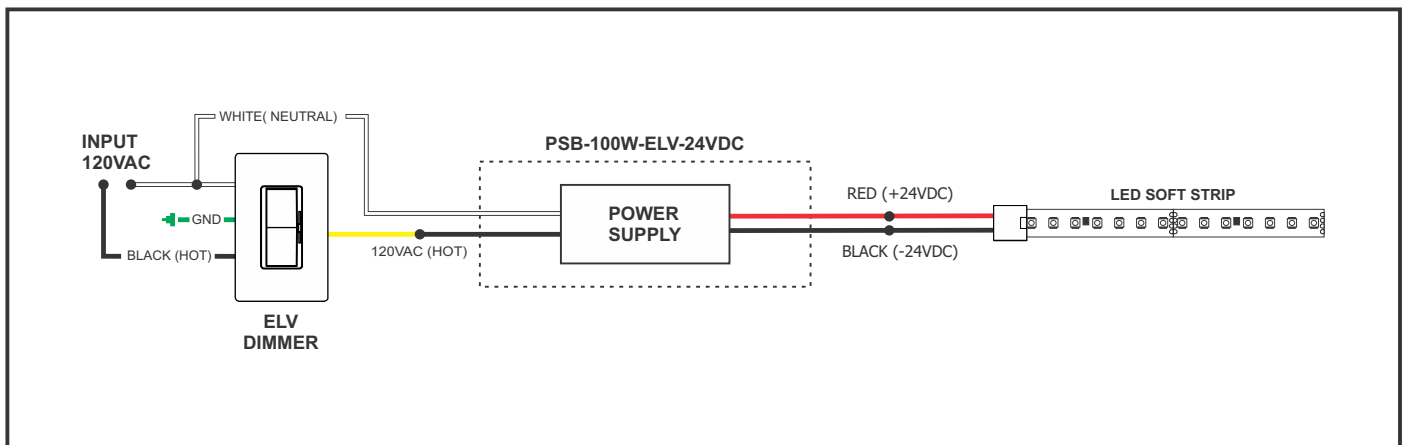

IMPORTANT INFORMATION REGARDING INSTALLATION AND REWORK OF SOFT STRIP LED

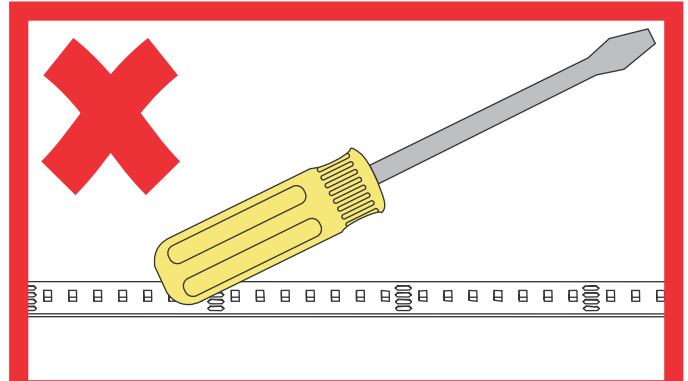
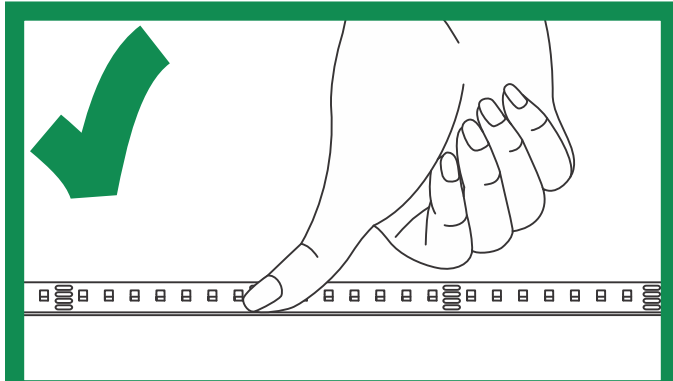
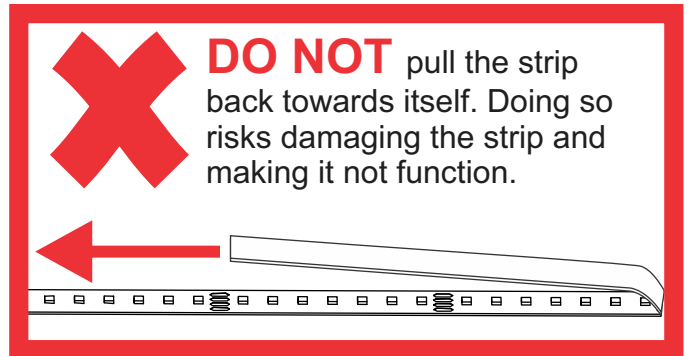
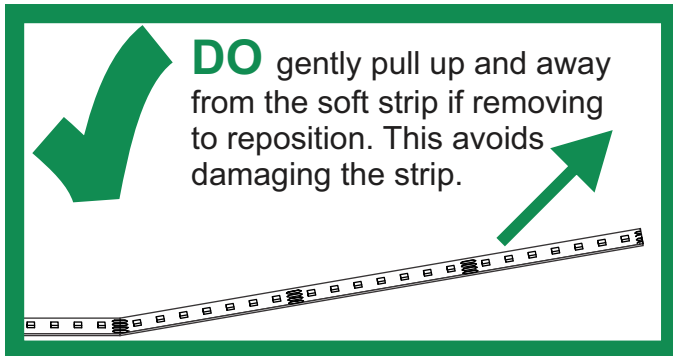

Relocating Soft Strip (Optional)

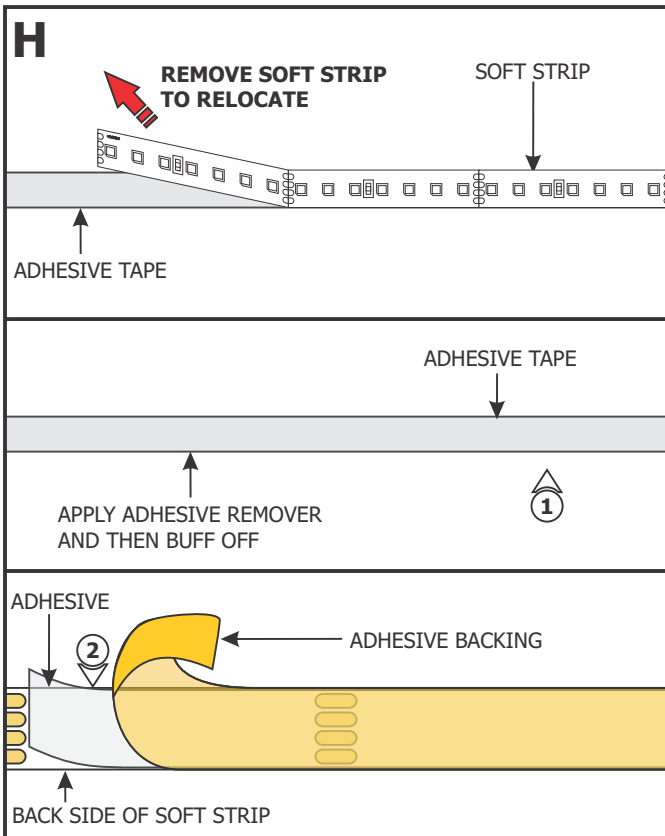

NOTE: If relocating the installed soft strip, make sure that the adhesive tape on back of the soft strip covers the entire strip. The adhesive tape isolates the strip from the installation surface. Damaged or inconsistent adhesive tape may cause the contacts on the back of the strip to come in contact with the conductive heat sink which will cause the strip to short and burn. Call PureEdge Lighting to get replacement adhesive tape and/or optional aluminum heat sink tape (SS-HR-F).

- 1:** To remove tape residue from back of the strip, apply WD-40, Goo Gone, or a mixture of warm water and lemon oil to the corner of a clean, dry towel. Gently buff the area containing the adhesive residue until it is completely removed.
- 2:** Gently remove a few inches from one side of the tape backing. Attach the adhesive tape to the back of the soft strip and apply moderate pressure to affix the tape. Continue this step a few inches at a time until the entire adhesive tape is attached to the back of the soft strip.
- 3:** Refer to Section Two to reinstall the soft strip.