



1718 W. Fullerton Chicago, IL 60614
 Ph: 773.770.1195 • Fax: 773.935.5613
 www.PureEdgeLighting.com • info@PureEdgeLighting.com
 © 2016 PureEdge Lighting. All Rights Reserved.

Installation Instructions for TruLine .5A and 1A TruQuad

IMPORTANT INFORMATION

- This instruction shows a typical installation.
- This product is wall or ceiling mount.
- This product is ETL listed for indoor use.

SAVE THESE INSTRUCTIONS!

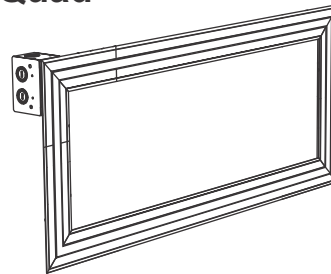

Pre-installation Guide

1: Depending on the size of the TruQuad, identify the design layout based on the 4 possibilities below.

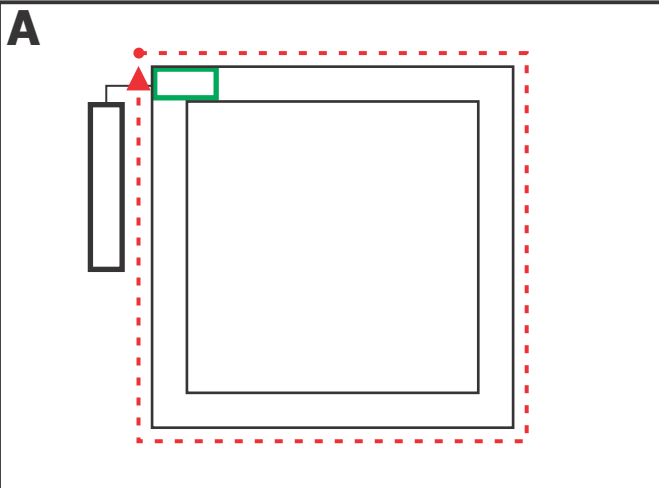

1 Junction Box
1 Remote Power Supply
1 Strip wrap around

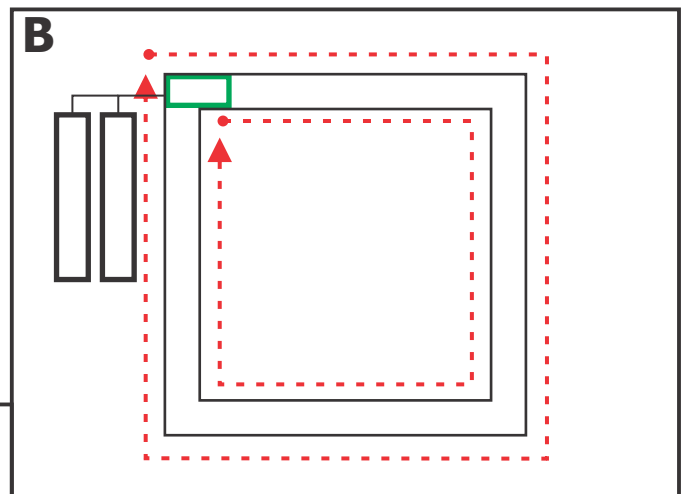

1 Junction Box
2 Remote Power Supplies
2 Strips wrap around on both sides of the channel

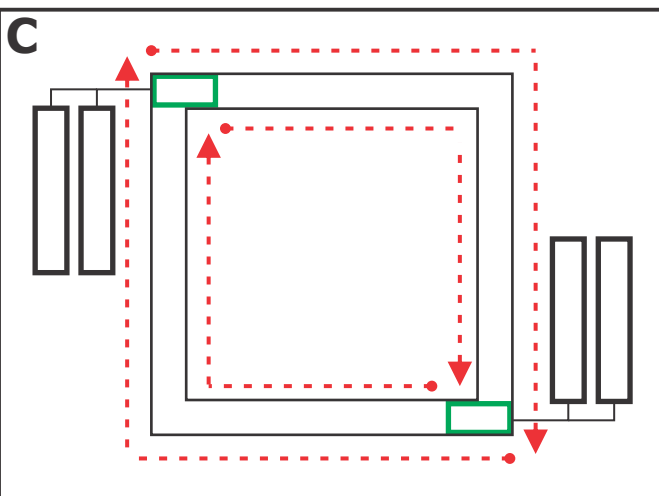

2 Junction Boxes
4 Remote Power Supplies
4 Strips wrap half way around on both sides of the channel

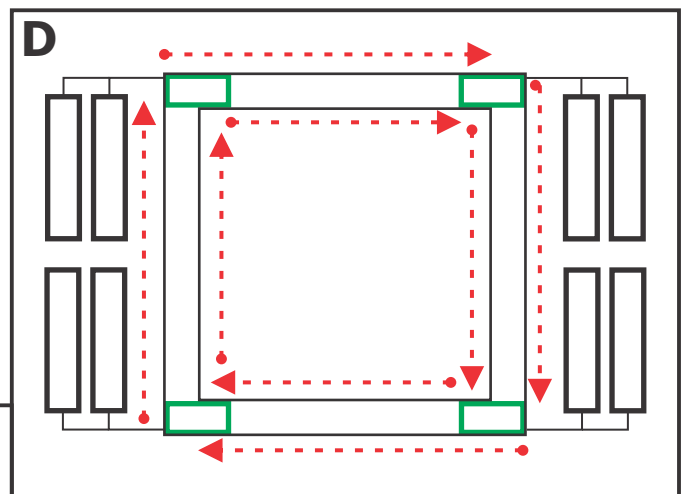

4 Junction Boxes
8 Remote Power Supplies
8 Strips going across on all sides of the channel

Included Components

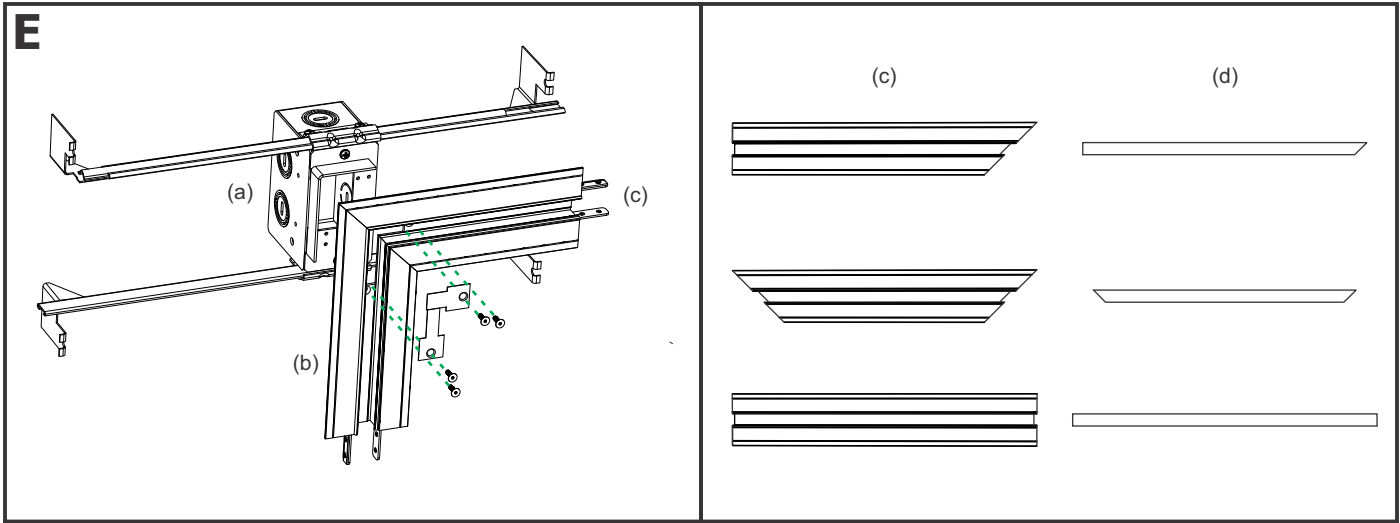

- a) Junction Box
- b) L-Picture Frame Power Channel Connector
- c) Channels and Joining Brackets
- d) Diffusers
- e) Mounting Bar, Mounting Brackets and Mounting Screws (not shown)

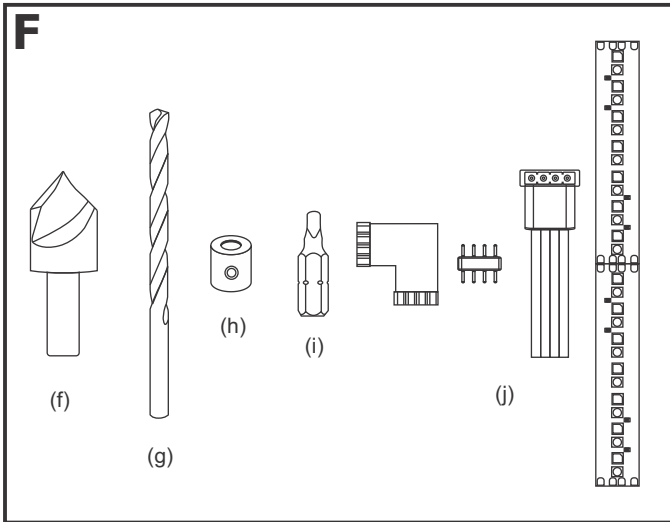

- f) Countersink
- g) Drill Bit
- h) Drill Bit Stop Collars
- i) Square-Recess Insert Bit
- j) LED Soft Strip and Power Connectors

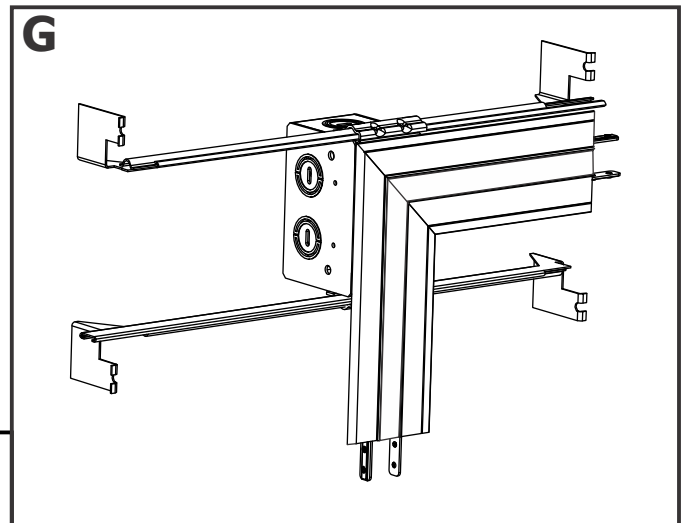

NOTE: Refer to Section One to prepare and install the junction box and power connections.

Section One: Prepare and Install Junction Box and Power Connections

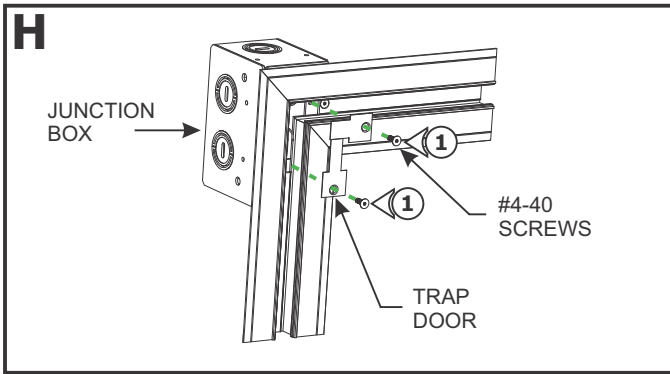

1: Remove the #4-40 screws from the junction box to remove the trap doors from the assembly using a 1/16" Allen wrench.

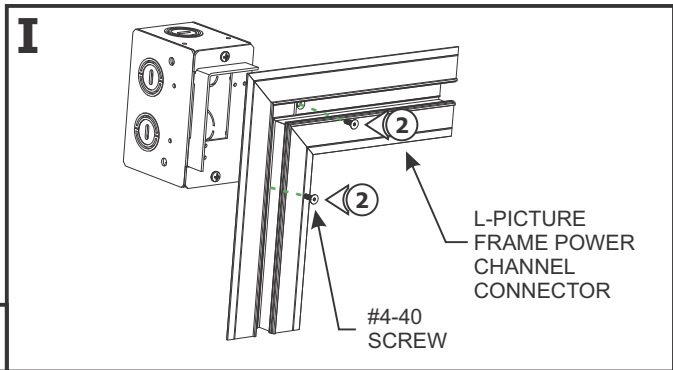

2: Remove the #4-40 screw from the junction box to remove the L-Picture Frame Power Channel Connector.

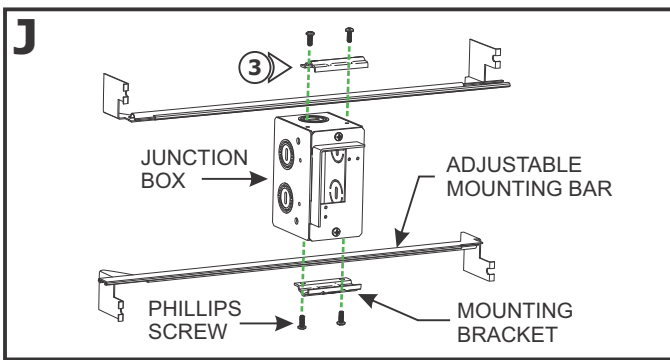

3: Mount each adjustable mounting bar to one side of the junction box and secure them with the mounting brackets and two Phillips screws provided.

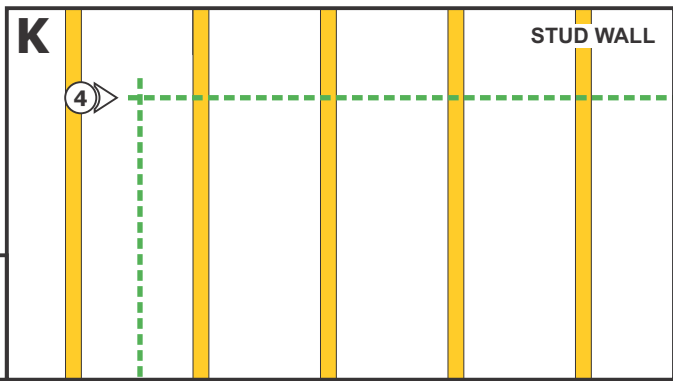

4: Measure and locate junction box to desired location. Determine the corner that the junction box will be installed to. Longer installation lengths may require two (opposing corners) or four (all corners) junction boxes.

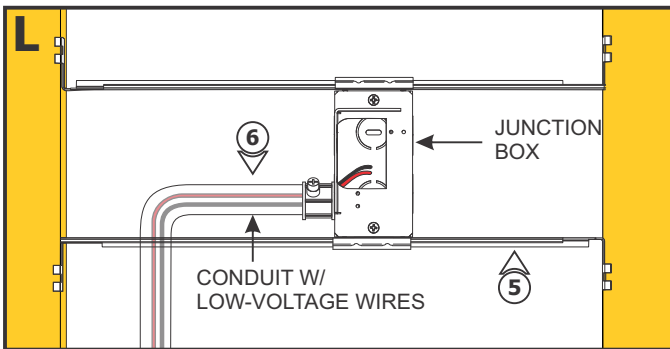

NOTE: The adjustable mounting bars mount to studs that are spaced 13" to 24" apart.

5: Place the lips on the adjustable mounting bars against the studs. Secure the adjustable bars to the studs with the #8 screws.

6: Install power supply (reference installation instructions included with power supply) and conduit (if required by local electrical code) and run low-voltage power wires to the junction box.

NOTE: Remote power supply wires must be present in junction box. Refer to instructions provided with power supply.

7: Connect the red power supply (24VDC+) wires to the red power connector wires with a wire nut.

8: Connect the black power supply (24VDC-) wires to the black power connector wires with a wire nut.

9: Place the wire nut connections inside junction box.

CAUTION: Unroll the entire LED strip from the reel and use the power connector to power the strip making sure there is no outage before continuing with the installation. Afterwards, carefully roll the LED strip loosely back into the reel.

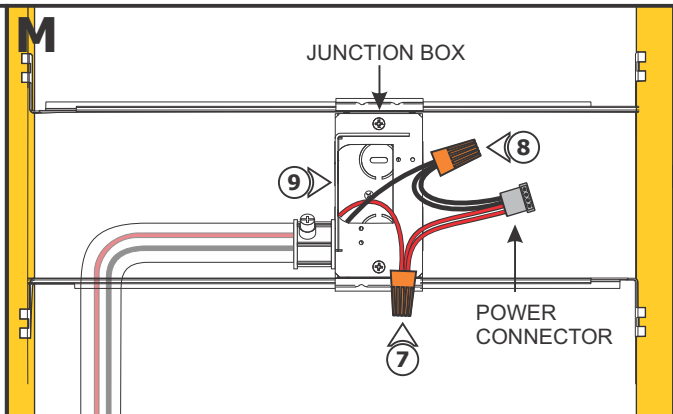

Section Two: Prepare Drywall and Install Channel

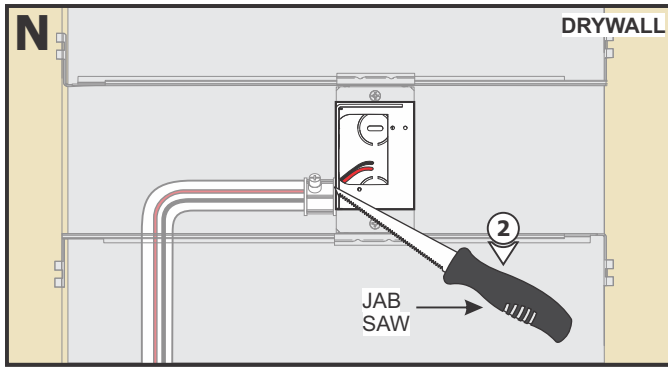

1: Install drywall.

2: Using location measurements from previous steps, mark the drywall and cut a section where the junction box will be located using a 6" fixed jab saw or other appropriate tool.

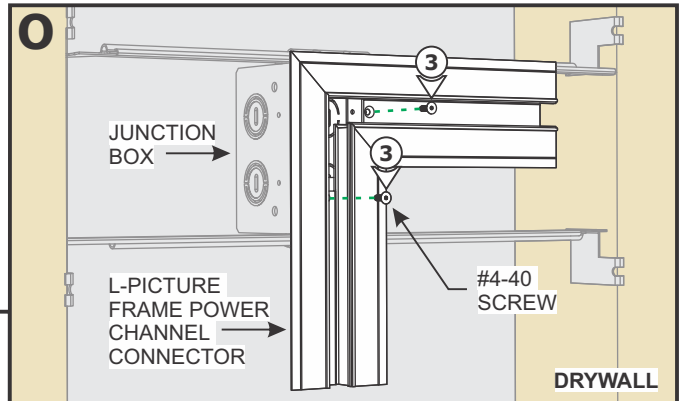

3: Attach the assembled L-Picture Frame Power Channel Connector to the junction box with the #4-40 screws using a 1/16" Allen wrench.

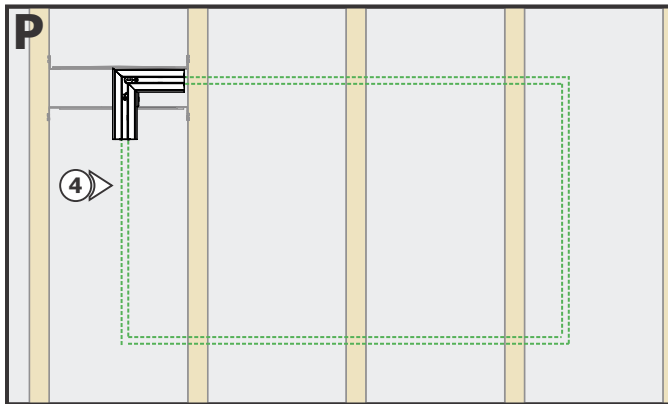

4: Mark the installation location on the drywall using a pencil or chalk line before cutting minimum 1.05" wide.

NOTE: For TruQuad 1A, mark the installation location on the drywall before cutting minimum 1.25" wide.

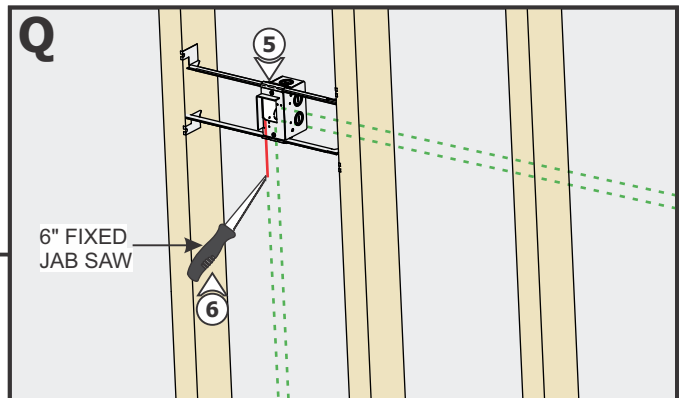

5: Remove the L- Picture Frame Power Channel Connector before cutting.

6: Cut the drywall along the marked installation path using a jab saw or other appropriate tool.

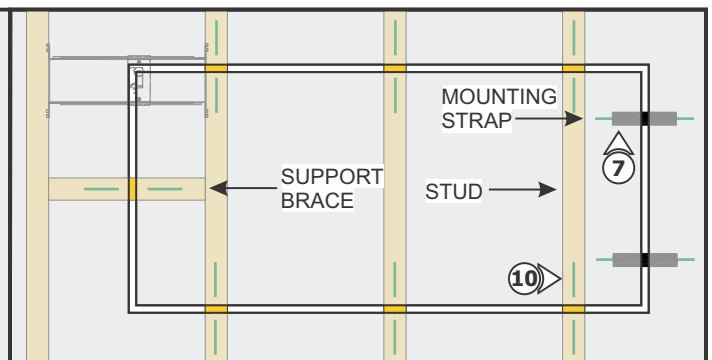
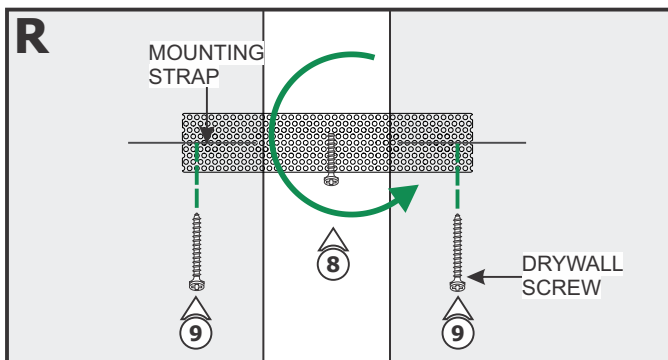

7: Install mounting straps behind the drywall where studs are not available (suggested spacing is every 32") by threading a drywall screw into the perforated material.

8: Place the mounting strap behind the cut drywall and rotate into place using the drywall screw as a handle.

9: Secure the mounting strap to the drywall using two drywall screws.

10: Mark the location of the studs and mounting straps on the drywall.

NOTE: For areas with lots of vibrations, it is suggested to install 2X4 support braces (suggested spacing is every 32") before installing and finishing drywall to avoid cracking of plaster.

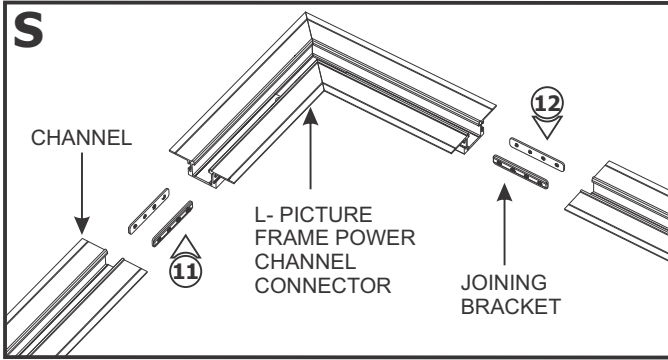

- 11:** Insert joiner bars halfway into the L-Picture Frame Power Channel Connector. Tighten the M3 set screws on each joiner bar with a 1.5mm Allen wrench.
- 12:** Slide the other section of channel onto the joining bars and tighten the remaining M3 set screws with a 1.5mm Allen wrench.

- 13:** Insert a 90° joiner bracket halfway into one mitered channel corner. Tighten the two M4 set screws on each joiner bar with a 2mm Allen wrench.
- 14:** Slide the other section of mitered channel onto the 90° joining brackets and tighten the remaining M4 set screws with a 2mm Allen wrench.

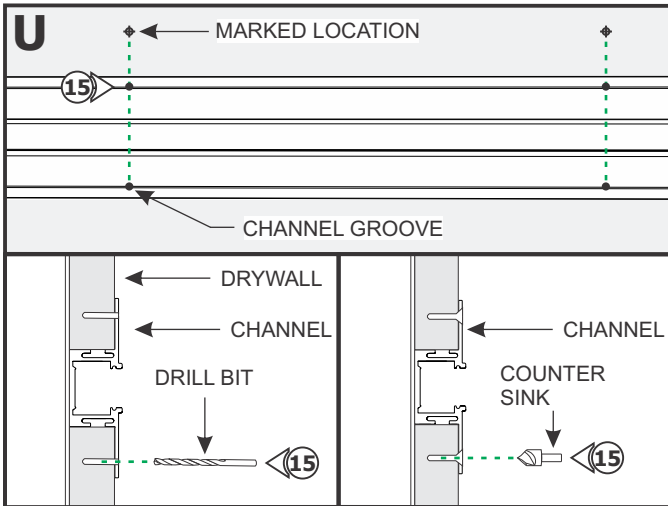
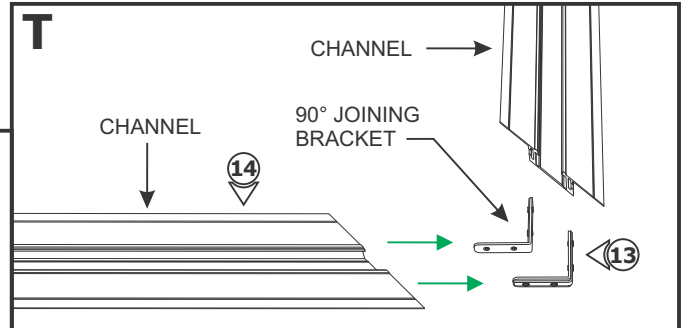

- 15:** Place the assembled channel to the drywall cutout. Using the marked locations on the drywall, drill and countersink the channel using the provided square drill with counter sink bit.

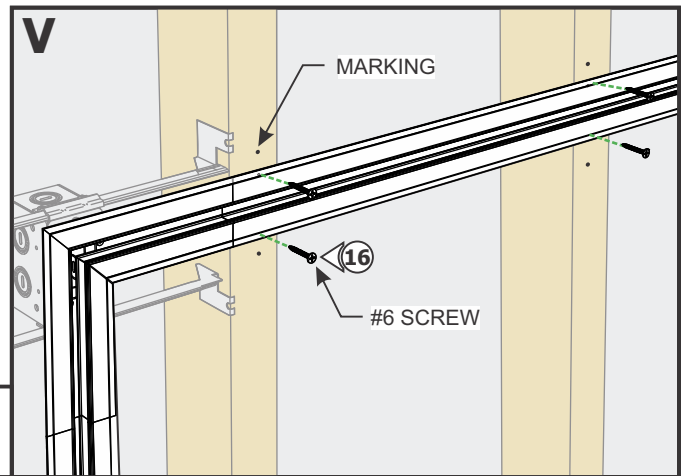

- 16:** Secure the channel to the studs/mounting straps through the drywall with the #6 screws using the provided square recess bit.

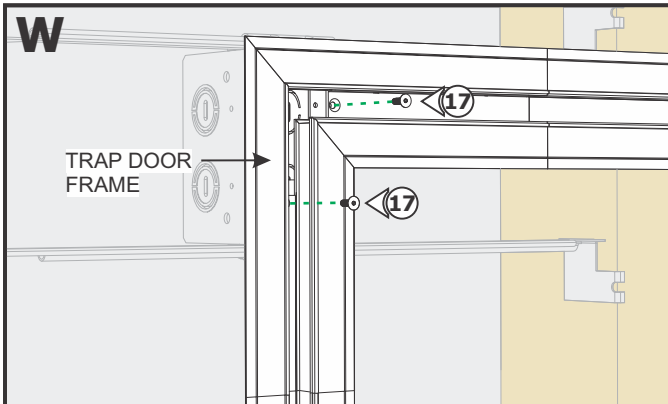

- 17:** Secure the L-Picture Frame Power Channel Connector to the junction box with the #4-40 screws.

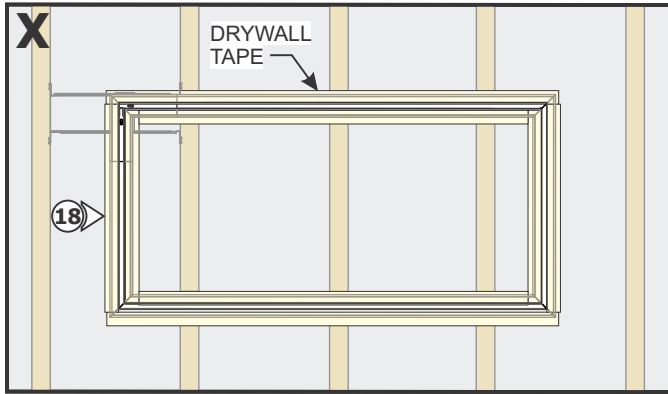

NOTE: For areas with lots of vibration, it is suggested to use Durabond to avoid cracking of plaster.

NOTE: Do Not use premixed joint compound "Soft Mud." No use compuesto para juntas premezclado "Soft Mud."

18: Must apply drywall tape (Ultra-Thin drywall tape suggested) along edges of channel to prevent cracking of plaster after installation. Do Not overlap strips of drywall tape.

19: Mask the interior surfaces of the channel using blue contractor's tape before plastering and painting.

20: Use a compound knife for a smooth compound spread. Sand, paint, and finish the plaster and drywall before removing the blue contractor's tape.

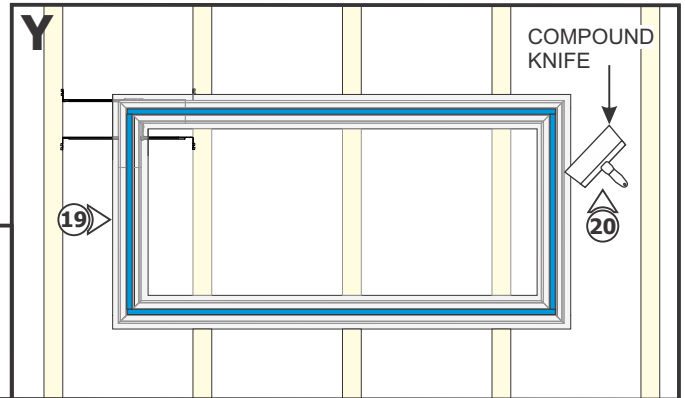

Section Three: Installing LED Soft Strip

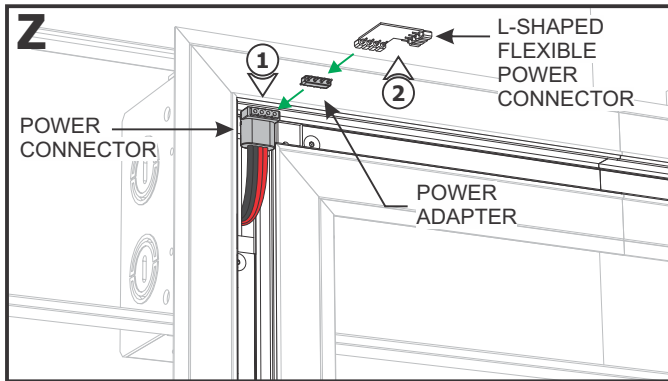

1: Insert the male-to-male power adapter to the power connector.

2: Connect the L-Shaped Flexible Power Connector to the male-to-male power adapter.

3: Place the assembled power connector into the channel where the LED soft strip will be installed.

4: Replace the trap door and secure using the #4-40 screw.

5: If necessary (depending on design), repeat step 1 through 4 for the other corners.

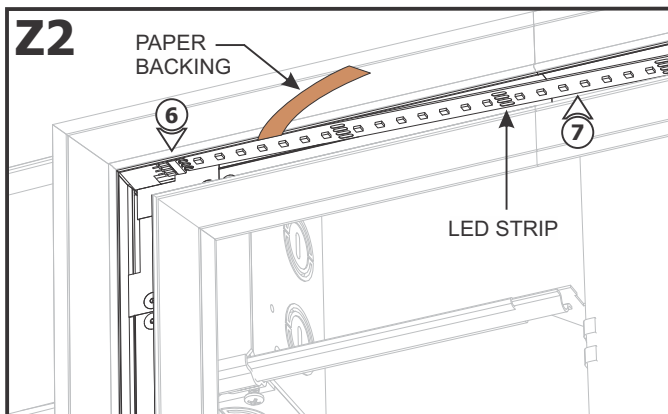
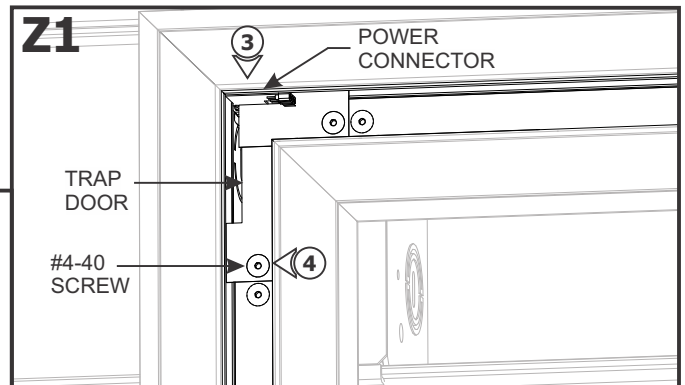

NOTE: If installation requires RGB, RGBW, or Tunable White, refer to wiring diagram on pages 10-12.

6: Carefully remove the backing from the LED soft strips, making sure not to remove the tape from the LED strips. Line up the red wire side of the power connector with the "+24VDC" marking on each LED strip. Push the male connector of the LED strips into the L-Shaped Flexible Power Connectors.

7: Firmly press down the adhesive portion of the LED soft strip onto the channel surface while removing the rest of the backing, making sure there are no air bubbles that can cause surface irregularities.

Z3

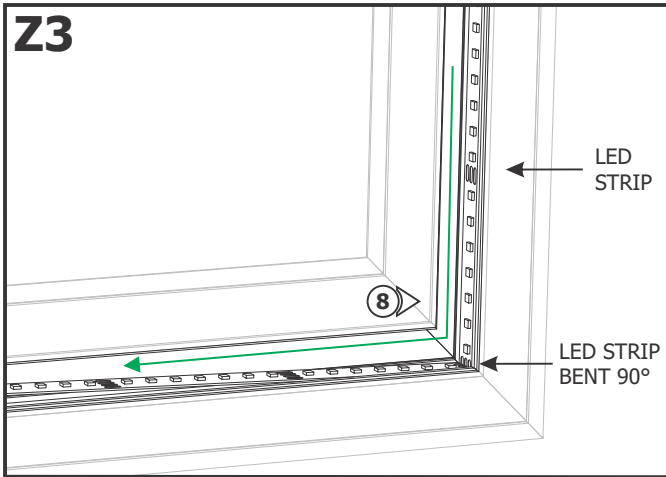

8: Continue applying LED soft strip in side of channel. Carefully bend the LED soft strip 90° to match the channel corner.

Z4

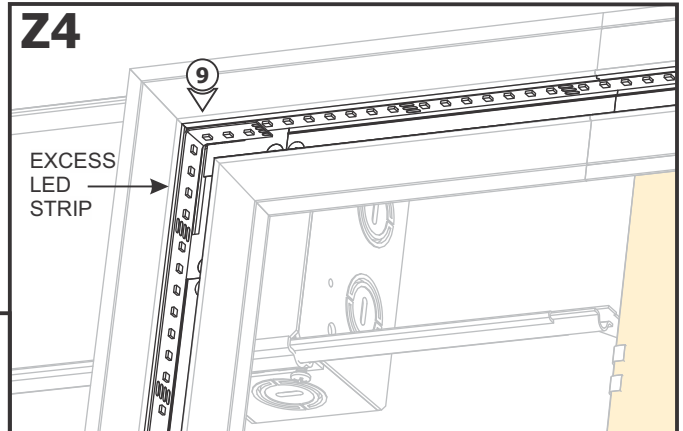

9: Trim excess LED soft strip **ONLY** at dashed cutting lines. Overlap excess LED soft strip at power connection to avoid dark spots in installation. Repeat for additional LED soft strip sections.

Z5

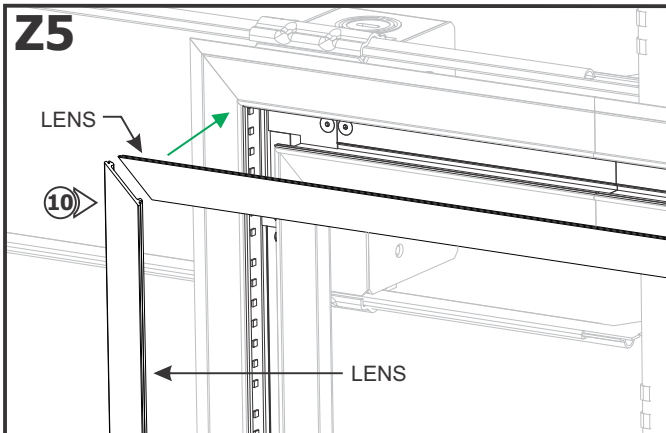

10: Insert lenses into the channel, ensuring all lenses are fully seated and properly aligned.

Section Four: Installing LED Soft Strip with Multiple Feeds

Z6

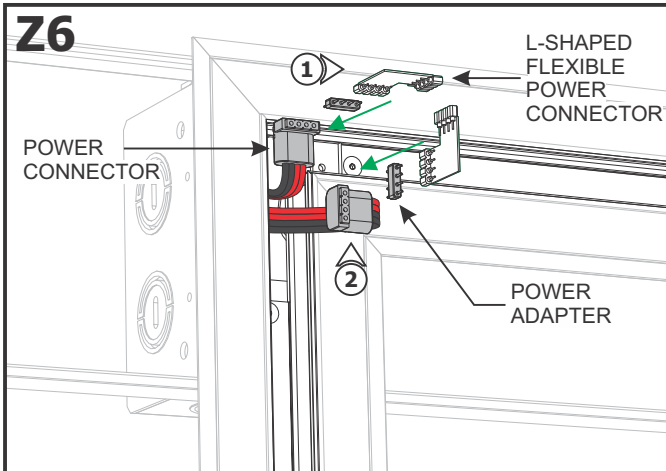

1: Insert the male-to-male power adapter to the power connector. Connect the L-Shaped Flexible Power connector to the male-to-male power adapter.

2: Repeat step 1 for the other power connector.

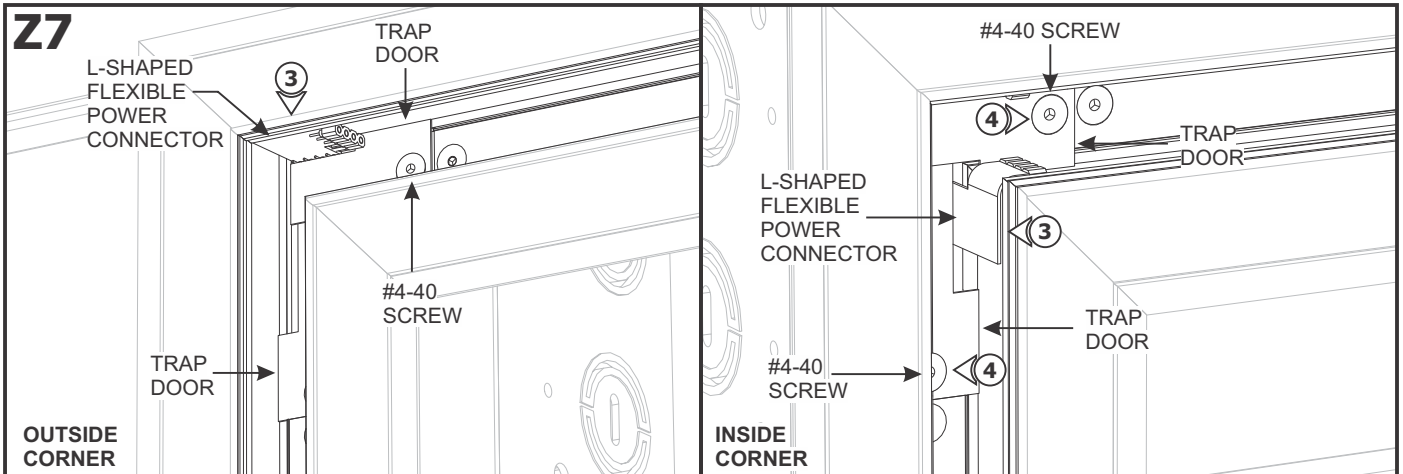

3: Place the assembled power connectors into the channel where the LED soft strips will be installed.

4: Replace the trap doors and secure using the #4-40 screws.

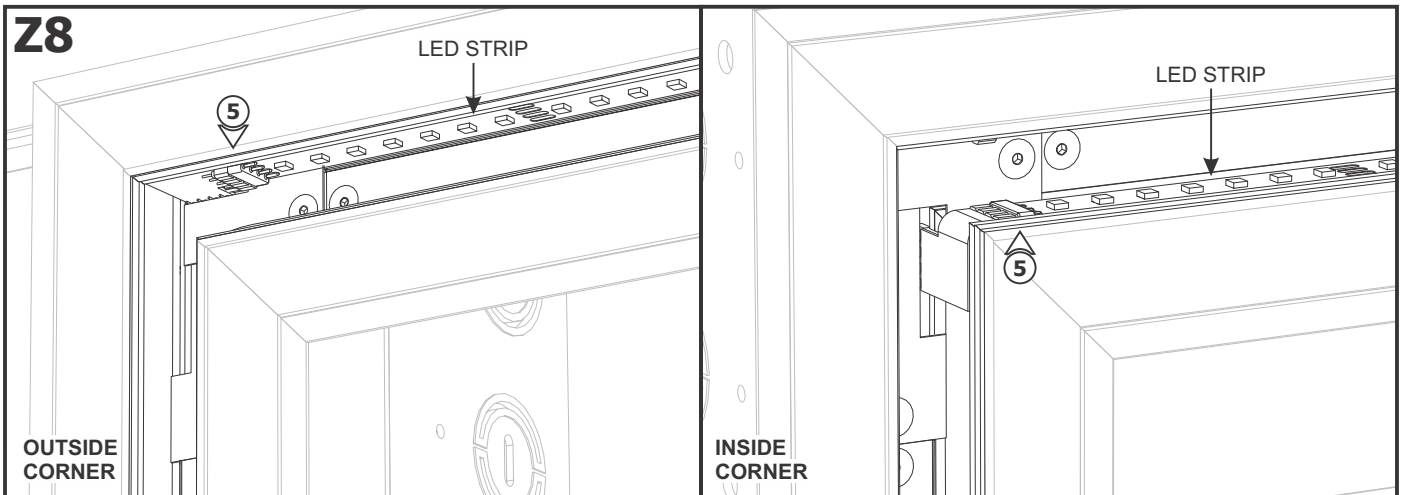

5: Repeat steps 6 through 8 in Section Three to install the LED strips.

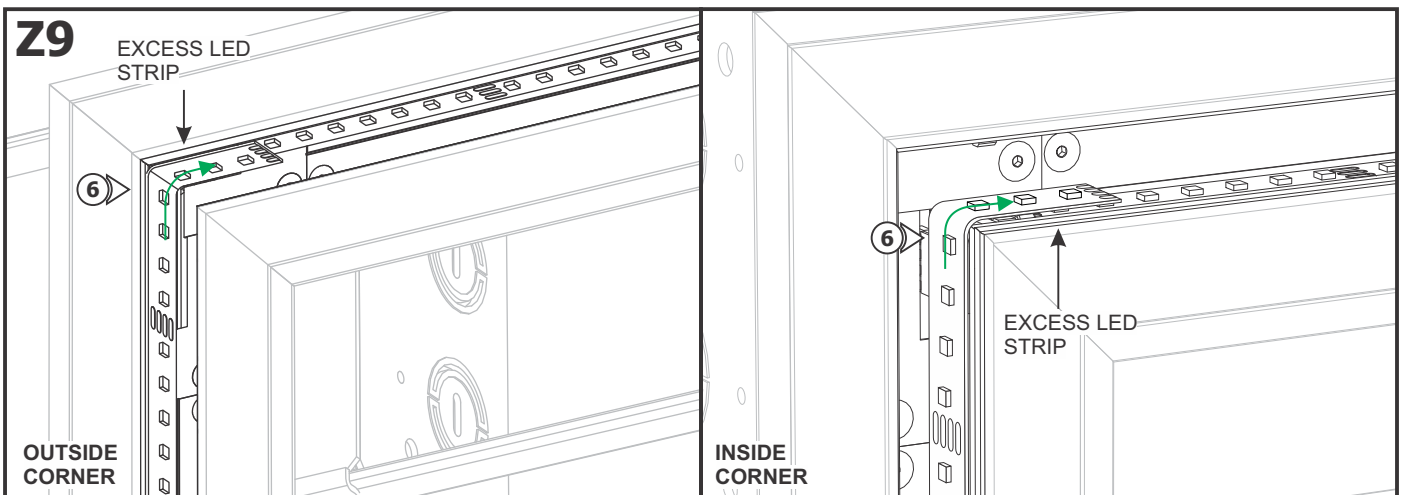

6: Trim excess LED soft strip ONLY at dashed cutting lines. Overlap excess LED soft strip at other power connection to avoid dark spots in the installation. Repeat for additional LED soft strip sections.

7: Insert lenses into the channel, ensuring all lenses are fully seated and properly aligned.

IMPORTANT INFORMATION REGARDING INSTALLATION AND REWORK OF SOFT STRIP LED

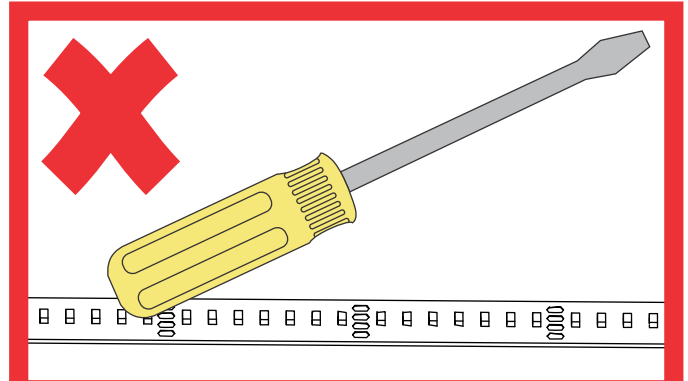
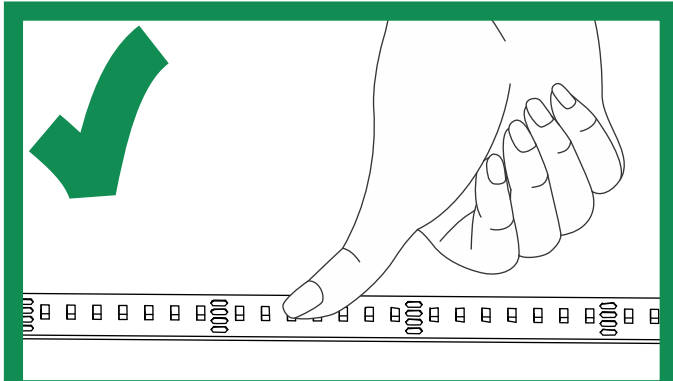
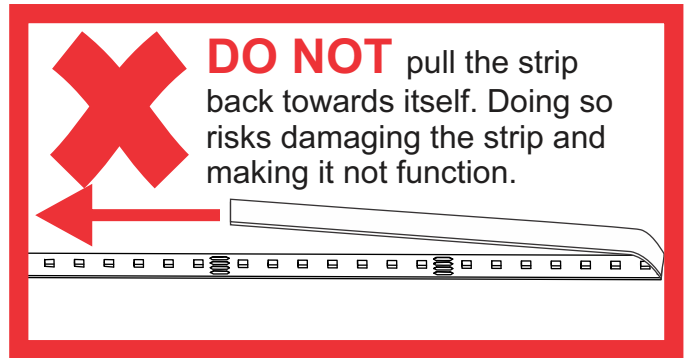
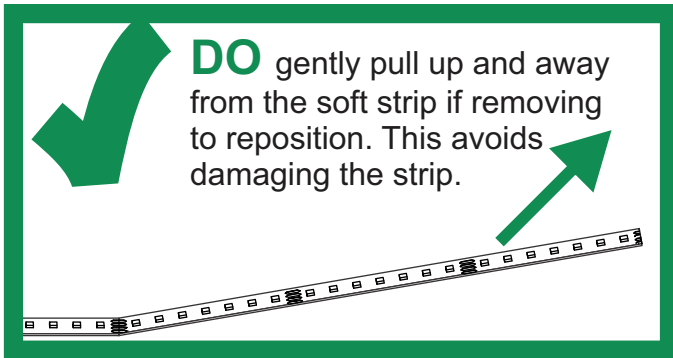

Relocating Soft Strip (Optional)

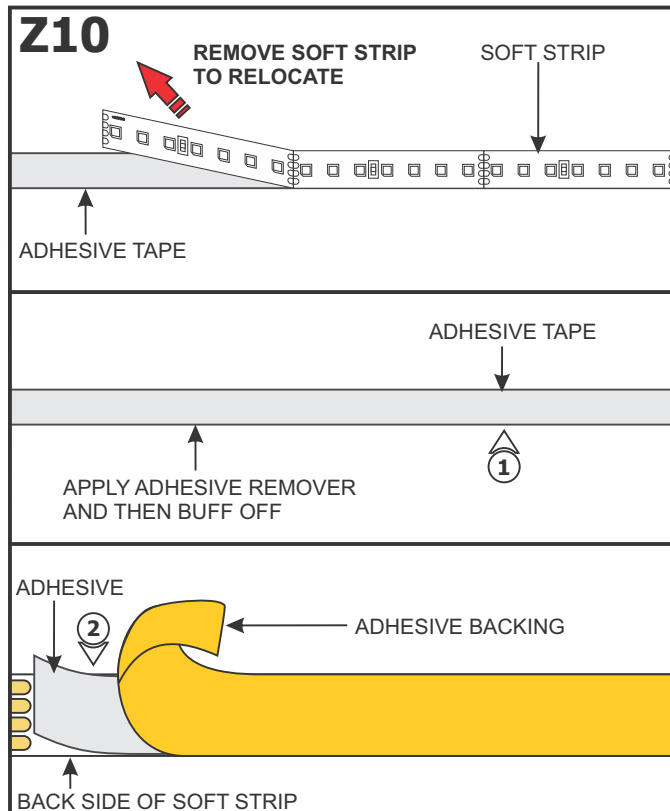

NOTE: If relocating the installed soft strip, make sure that the adhesive tape on back of the soft strip covers the entire strip. The adhesive tape isolates the strip from the installation surface. Damaged or inconsistent adhesive tape may cause the contacts on the back of the strip to come in contact with the conductive heat sink which will cause the strip to short and burn. Call Edge Lighting to get replacement adhesive tape and/or optional aluminum heat sink tape (SS-HR-F)

- 1: To remove tape residue from back of the strip, apply WD-40, Goo Gone, or a mixture of warm water and lemon oil to the corner of a clean, dry towel. Gently buff the area containing the adhesive residue until it is completely removed.
- 2: Gently remove a few inches from one side of the tape backing. Attach the adhesive tape to the back of the soft strip and apply moderate pressure to affix the tape. Continue this step a few inches at the time until the entire adhesive tape is attached to back of the soft strip.
- 3: Refer to the steps in Section 3 or Section 4 to reinstall the soft strip.

Wiring Diagrams

General 24VDC Configuration

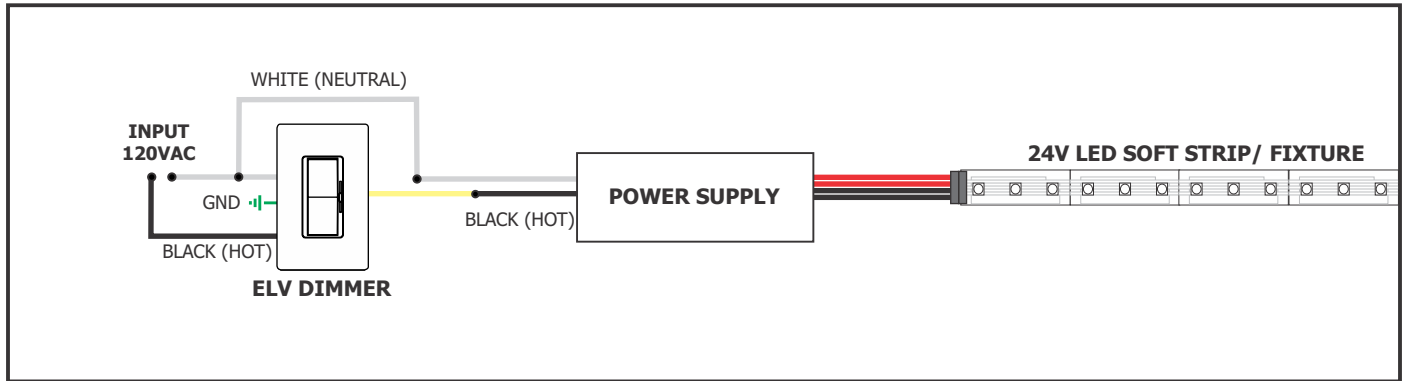

Standard RGB Configuration

Using LED Power Supply with RGB Soft Strip & CDP, CTP or CDMX Control

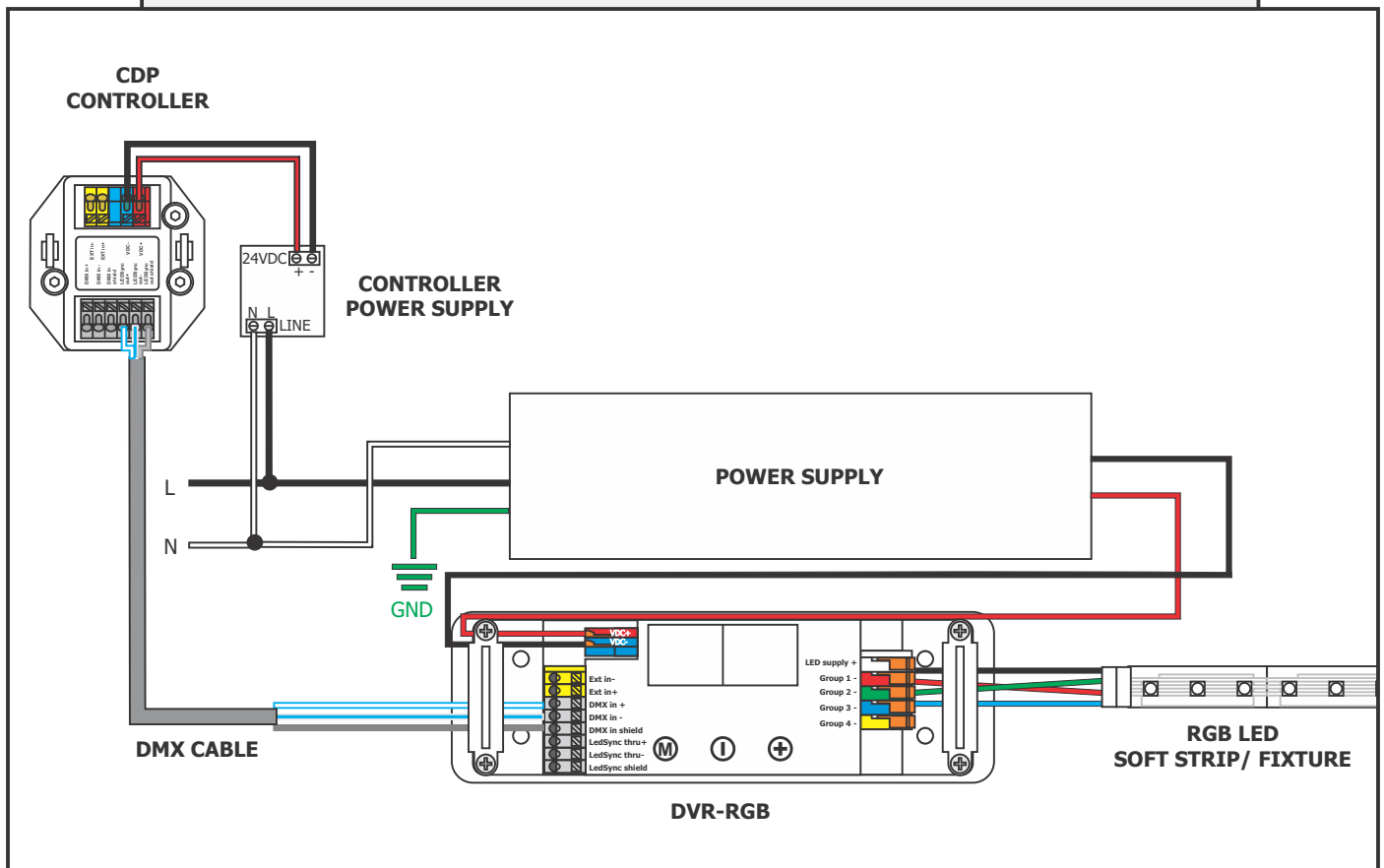

RGB+W Configuration

Using LED Power Supply with RGB+W Soft Strip & CDP, CTP or CDMX Control

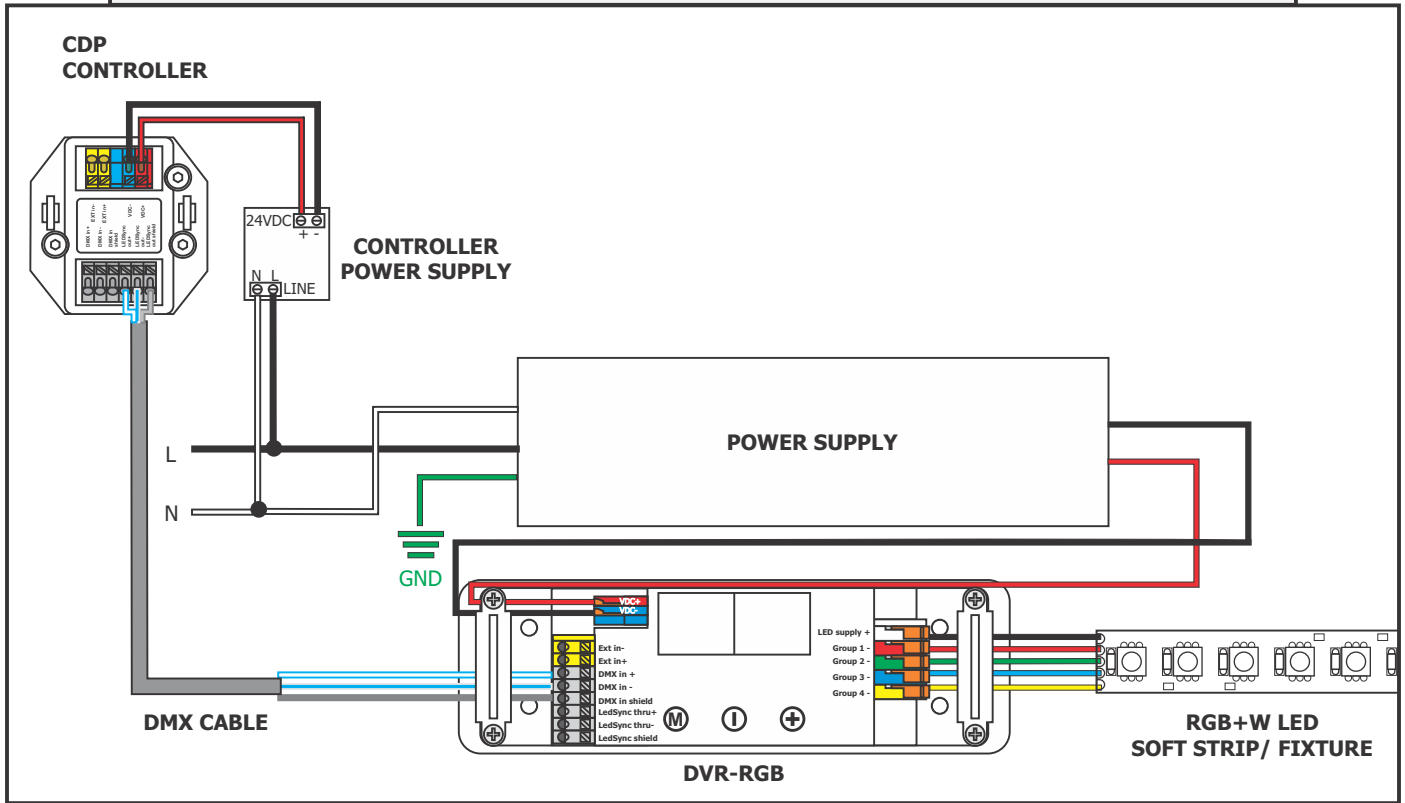

Tunable White Configuration

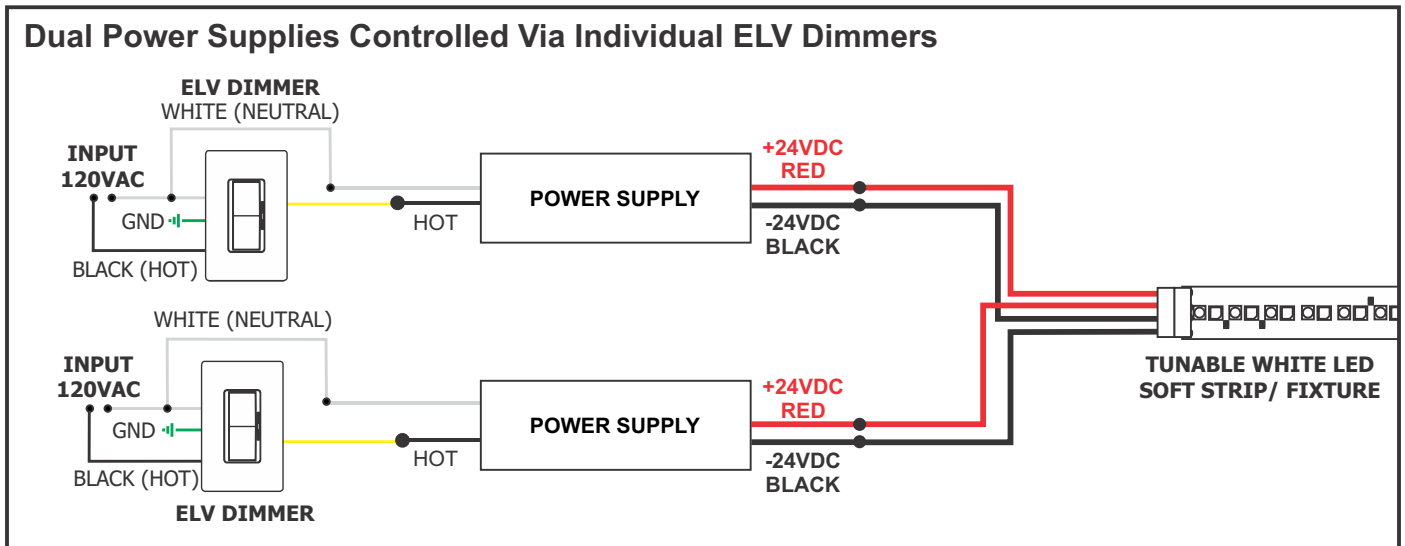

Tunable White Configuration

