



1718 W. Fullerton Chicago, IL 60614  
 Ph: 773.770.1195 • Fax: 773.935.5613  
 www.PureEdgeLighting.com • info@PureEdgeLighting.com  
 © 2016 PureEdge Lighting. All Rights Reserved.

## Installation Instructions for TruTrack 2-Circuit L-Shaped Power Feed

**TR24-2C-LP**

### IMPORTANT INFORMATION

- This product is for indoor locations only.
- This instructions shows a typical installation.
- Before beginning any electrical work, ensure that the power to the electrical box is off.

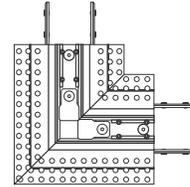
**SAVE THESE INSTRUCTIONS!**

### Section One: Install the Junction Box

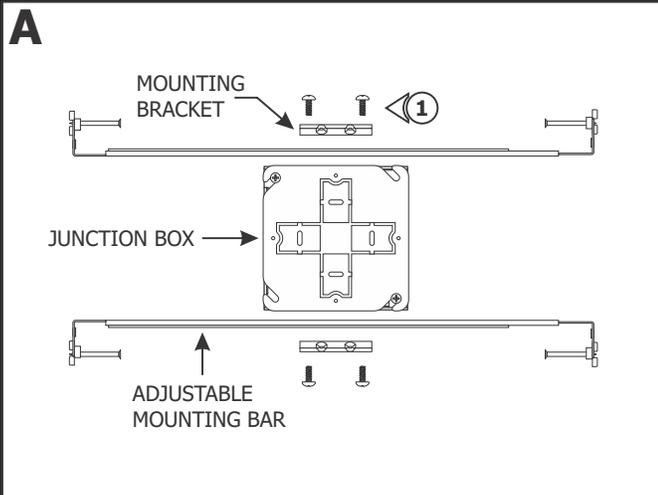

- 1:** Mount each adjustable mounting bar to one side of the junction box and secure them with the mounting brackets and two Phillips screws provided.

**NOTE:** Adjustable mounting bars mount to studs that are spaced 14.5" to 25" apart.

- 2:** Select the appropriate knockouts on the mounting plate and remove it using a flathead screwdriver or other appropriate tool.
- 3:** Place the adjustable mounting bar tabs against the ceiling joists. Secure the adjustable bars to the joists with the #8 screws.
- 4:** Install conduits (if required by local electrical code) and run the low voltage wires 24VDC coming from the remote power supplies to the junction box.

**NOTE:** Only use 0-10V and UNI power supplies with this product. See the wiring diagram provided with the power supply instructions.

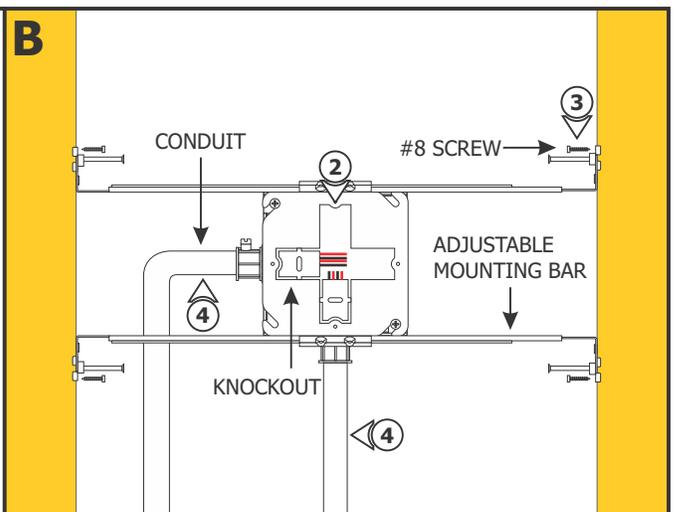

## Section Two: Install L-Shaped Power Feed

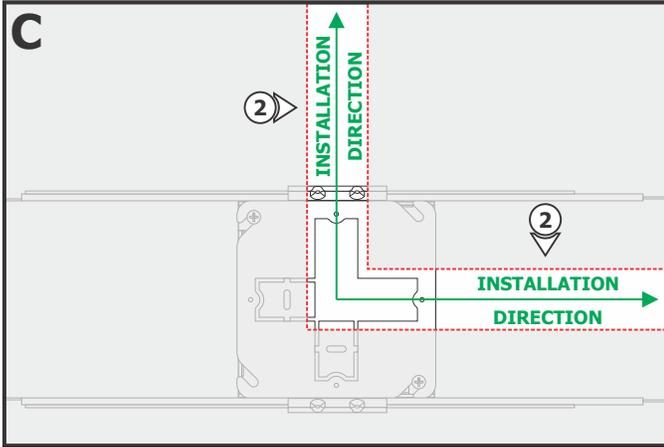

- 1: Cut a section of drywall to expose the junction box area.
- 2: Mark and cut out the area where the installation will be located from the center of the junction box opening. Install the drywall.

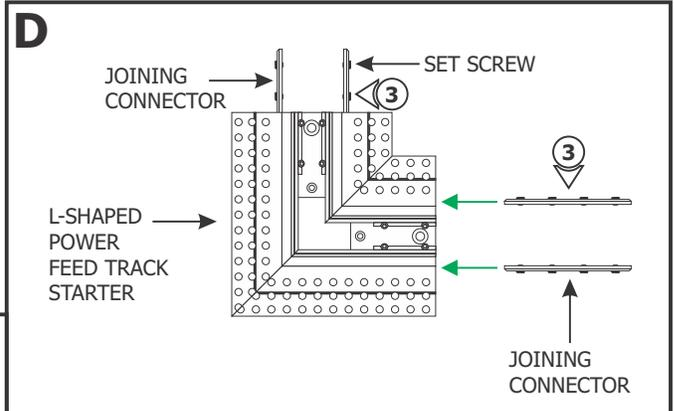

- 3: Insert the joining connectors half way into the L-Shaped Power Feed Track Starter and tighten the set screws using the provided Allen wrench.

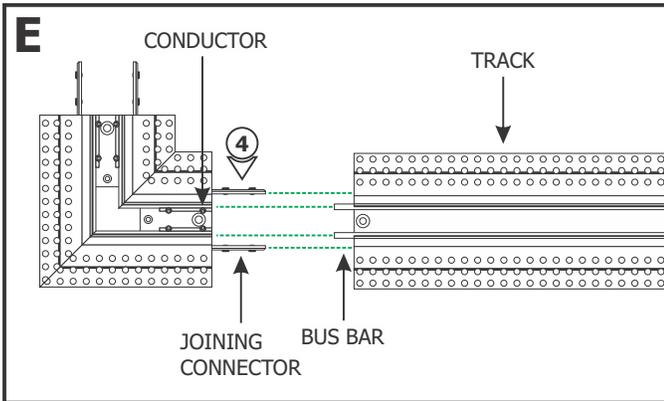

- 4: Slide the tracks over the joining connectors on the L-Shaped Power Feed Track Starter and insert the bus bars into the seamless conductors.
- 5: Tighten the set screws on the joining connectors and the set screws on the seamless conductors using the provided Allen wrenches.

**NOTE:** Refer to wiring diagrams on pages 5 and 6 to power the track.

- 6: Strip 3/8" off of the fixture wire and the low voltage power supply wires.
- 7: Pull up the levers of one lever nut, and insert the red +24VDC power supply wire and the red fixture wire into the lever nut. Push the levers down to connect and lock into place.
- 8: Pull up the levers of the other lever nut and insert the black -24VDC wire from the same power supply and the black fixture wire. Push the levers down to connect and lock into place.
- 9: Lightly tug on the wires to ensure they are secured in place. Place the lever nuts inside the junction box.
- 10: Repeat steps 6 through 9 to power the other side of the track.
- 11: Feed the power supply wires for the LED Soft Strips through the L-Shaped Power Feed Track Starter opening.

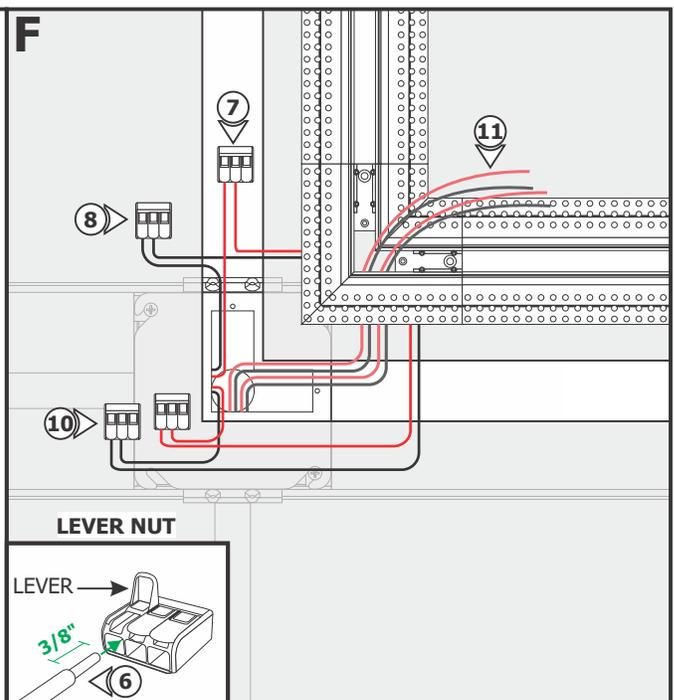

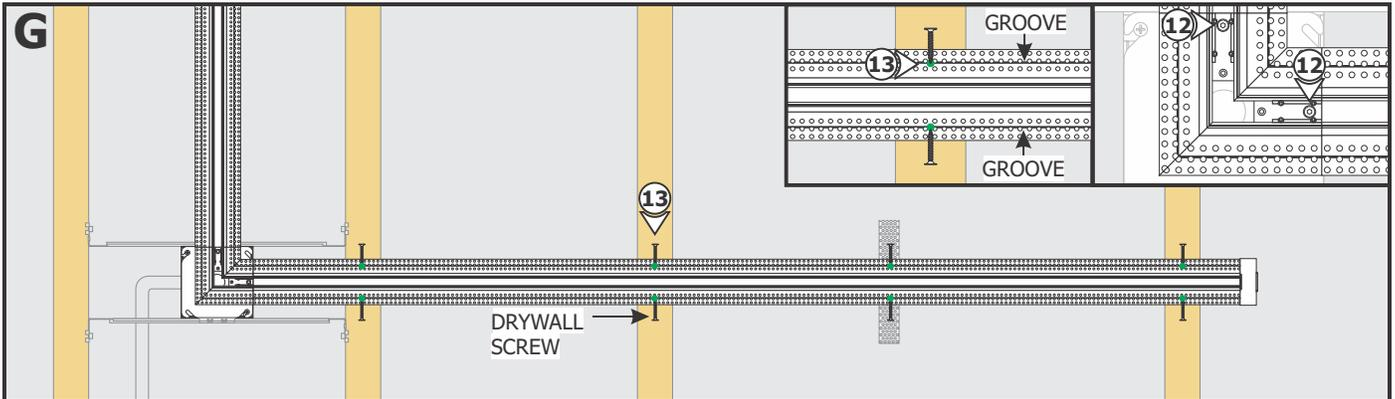

**12:** Secure the L-Shaped Power Feed to the junction box with the two screws using an Allen wrench.

**13:** Add screws along the groove lines of each track to secure the tracks in place.

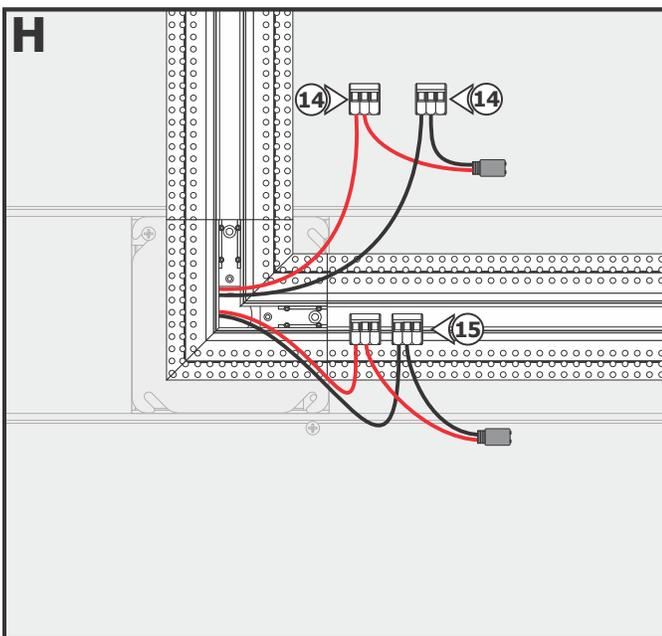

**NOTE:** Refer to wiring diagrams on page 5 to power the LED Soft Strips.

**14:** Connect the red wire of the Soft Strip Power connector to the red +24VDC wire of the power supply with a lever nut. Connect the black wire of the same power connector to the black -24VDC wire of the same power supply with a lever nut.

**15:** Repeat step 14 for the other Soft Strip Power connector and power supply.

**CAUTION:** Unroll the entire LED strip from the reel and use the power connector to power the strip making sure there is no outage before continuing with the installation. Afterwards, carefully roll the LED strip loosely back into the reel.

**CAUTION:** Test the Track circuit with a track head.

**NOTE:** Refer to the TruTrack Recessed Channel instructions to plaster and complete the installation.

### Section Three: Install the LED Soft Strip

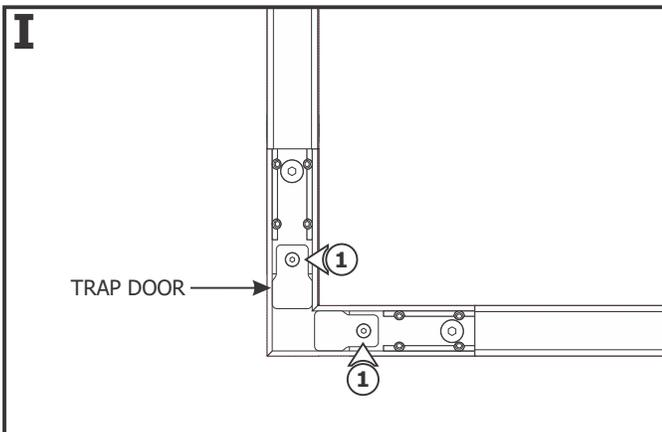

**1:** Secure the trap doors to the L-Shaped Power Feed with the provided set screws using an Allen wrench.

**2:** Gently uncoil the LED soft strip before applying to the channel otherwise the strip may lift off of the surface.

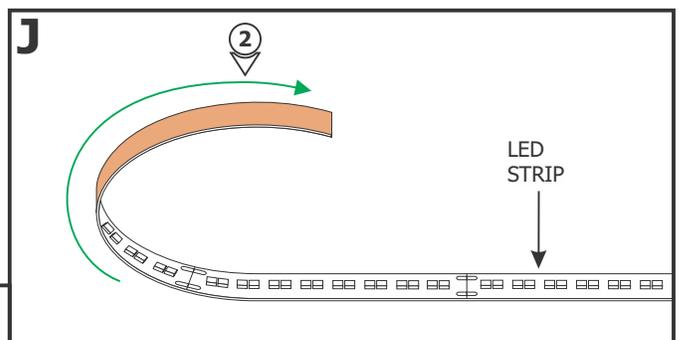

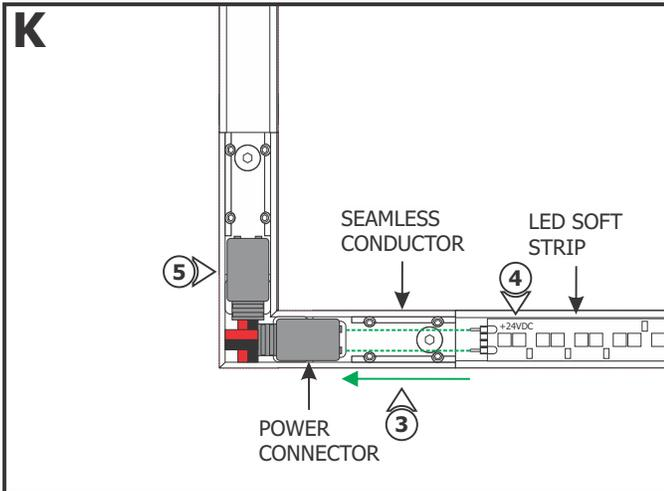

**3:** Carefully remove the backing from the LED Soft Strip, making sure not to remove the tape. Place or slide the LED Soft Strip through the seamless conductor.

**4:** Align the red wire side of the power connector with the +24VDC marking on the LED Soft Strip and push the LED Soft Strip pins into the power connector.

**5:** Repeat steps 3 and 4 for the other Soft Strip Power Connector and LED Soft Strip.

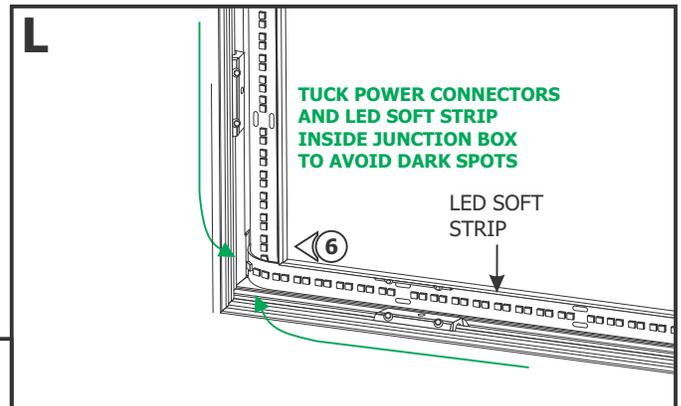

**6:** Place the Soft Strip Power Connectors or excess LED soft strips inside the junction box to avoid dark spots.

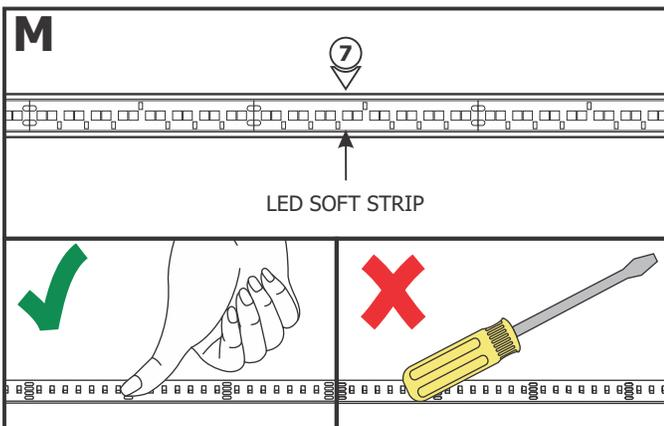

**7:** Firmly press down the adhesive portion of the LED Soft Strip onto the track surface while removing the rest of the backing, making sure there are no air bubbles that can cause surface irregularities.

# General Wiring Diagram for LED Soft Strips

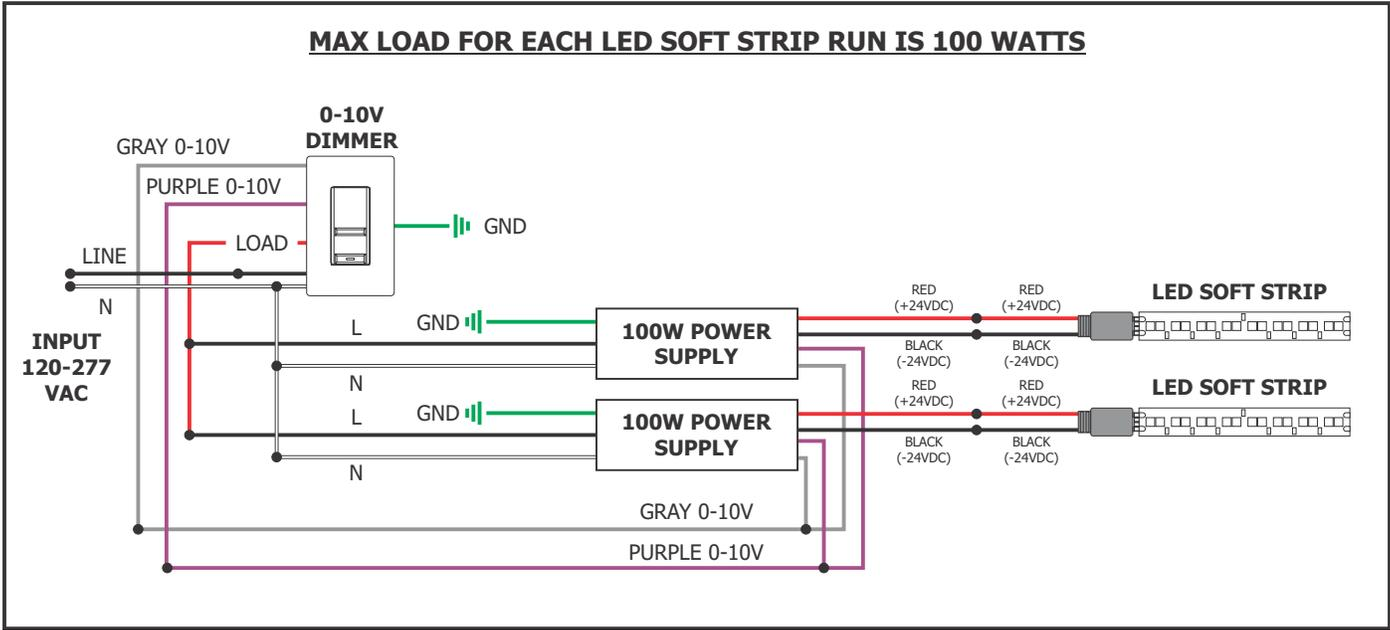

# General Wiring Diagrams for Track

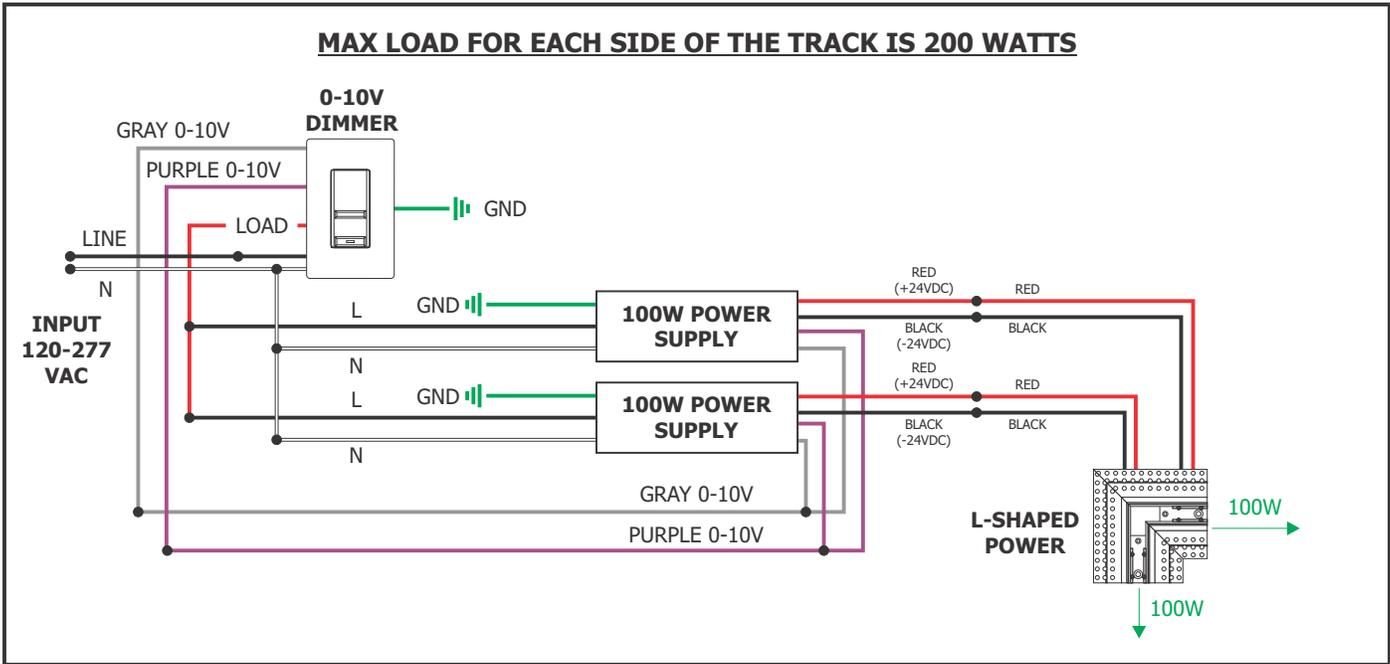

**MAX LOAD FOR EACH SIDE OF THE TRACK IS 200 WATTS**

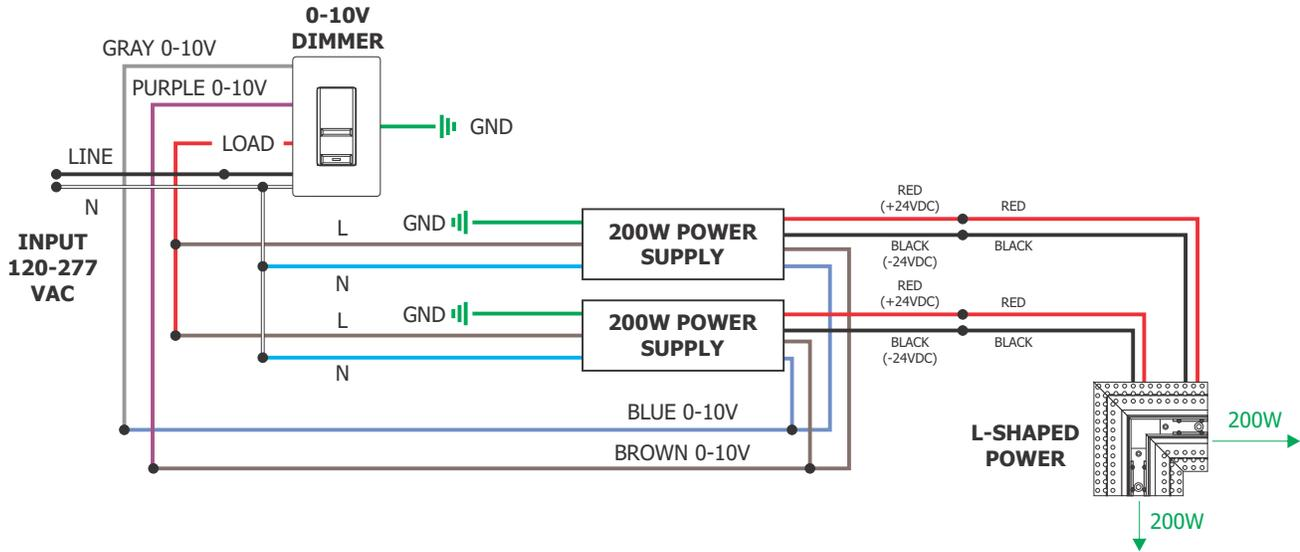

**SINGLE MAX LOAD FOR BOTH SIDES OF THE TRACK IS 200 WATTS**

