



EDGE
LIGHTING

© 2017 Edge Lighting. All Rights Reserved.

1718 W. Fullerton Ave
Chicago, IL 60614
Tel: 773-770-1195
Fax: 773-935-5613
www.edgelighting.com
info@edgelighting.com

TW2-T1-1RE-_-2K4K-_-

TW2-T1-4SQ-_-2K4K-_-

Installation Instructions for **Twiggy Tubular Lens 24VDC, Tunable White 2000K-4000K**

IMPORTANT INFORMATION

- This instruction shows a typical installation.
- This product is wall mount only.
- This product is dimmable with a low-voltage electronic dimmer.
- This product must be installed by a qualified electrician.
- The 1RE version mounts to the provided CV2_1RE_JBOX. The 4SQ version mounts to standard electrical box with plaster ring or octagon box.
- This product requires remote 24VDC ELV power supplies (sold separately) or a 24VDC RGB power supply (sold separately). (See pages 4-7 for installation steps.)

SAVE THESE INSTRUCTIONS!

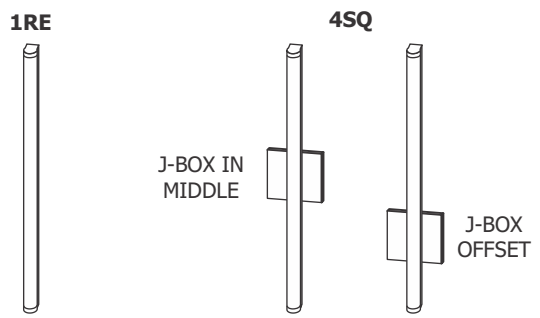

Section One: TW2-1RE Version

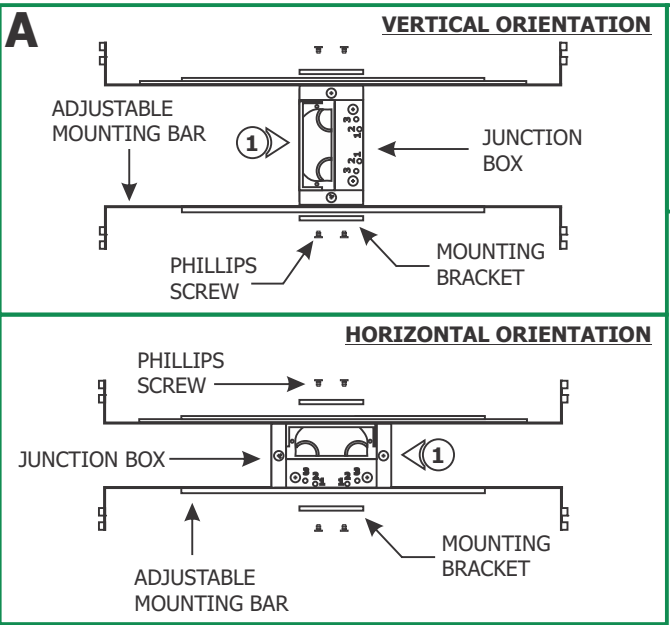

NOTE: Before beginning any electrical work, ensure that the power to the electrical box is off.

1: Determine channel orientation. Mount each adjustable mounting bar to one side of the junction box and secure them with the provided mounting brackets and two Phillips screws.

NOTE: The adjustable mounting bars mount to studs that are spaced 13" to 24" apart.

NOTE: Ensure the opening of the junction box is aligned with the center of the desired fixture location. If necessary, adjust the junction box location by loosening the screws and sliding the junction box to the proper location. Tighten the Phillips screws after adjusting.

- 2:** Select the location between the two studs for the junction box to be mounted.
- 3:** Place the adjustable mounting bars between the studs.
- 4:** Make sure the lips on the adjustable mounting bars are against the studs. Secure the adjustable bars to the studs with the eight #8 screws.

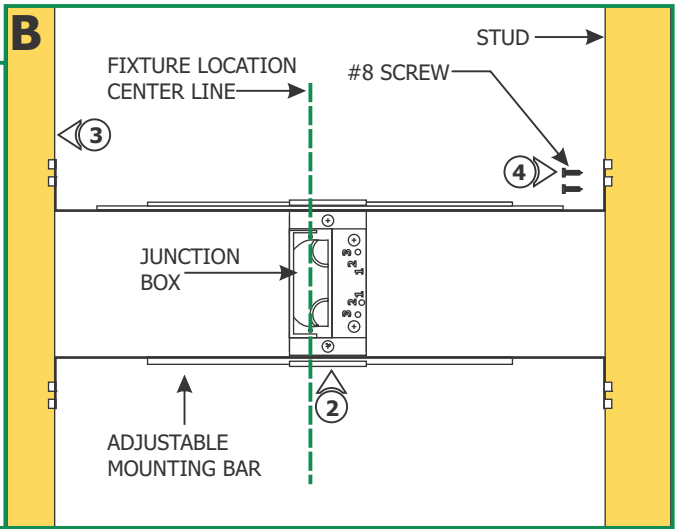

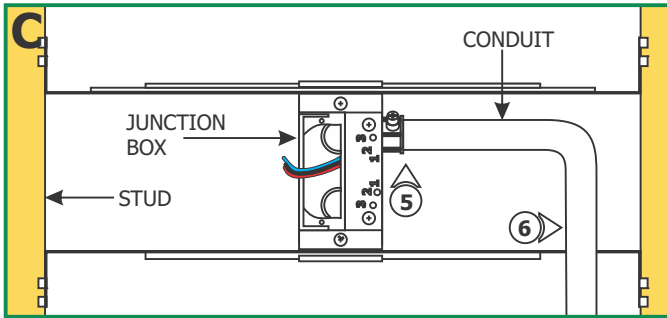

5: Remove a knockout to install the power line conduit.

6: Install the conduit and run the wire connections from the required DMX controller or the alternate two ELV dimmers (see wiring diagrams on pages 7 and 8.) Refer to Section Four for installation and setup.

7: Mark the rectangular junction box opening shape on drywall where the junction box will be located.

8: Cut out the marked rectangle opening, using a "Dremel Multi-Max" with the "wood & drywall" cutting bit.

9: Install & finish drywall.

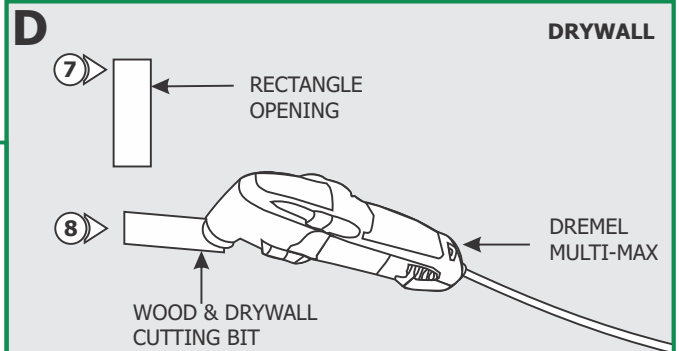

DRYWALL

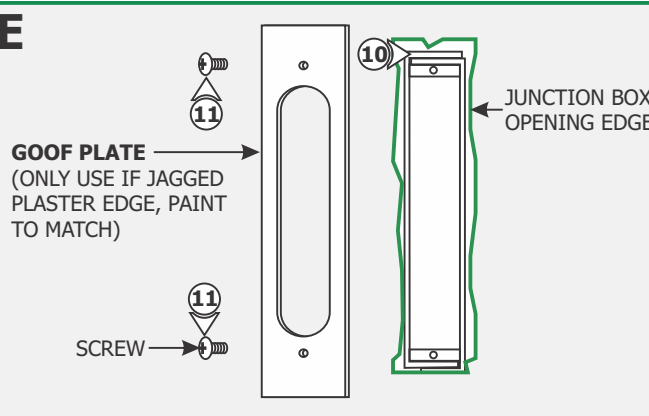

10: Install the drywall and plaster around the junction box opening. Sand and then paint.

11: If necessary: Use the Goof Plate if the junction box opening has a lot of imperfection/jagged edges. Install the provided goof plate (paint to match prior) with the two screws.

12: Complete installation by following steps in Section Three.

Section Two: TW2-4SQ Version

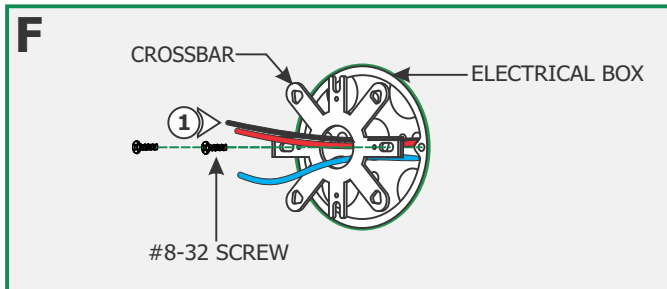

1: Feed the wires coming from the DVR (DMX controller) through the crossbar center hole and mount the crossbar to the electrical box holes with the two #8-32 screws provided. For alternate wiring with two ELV dimmers, see the wiring diagram on page 8.

2: Complete installation by following steps in Section Three.

Section Three: Install Fixture For Both Versions

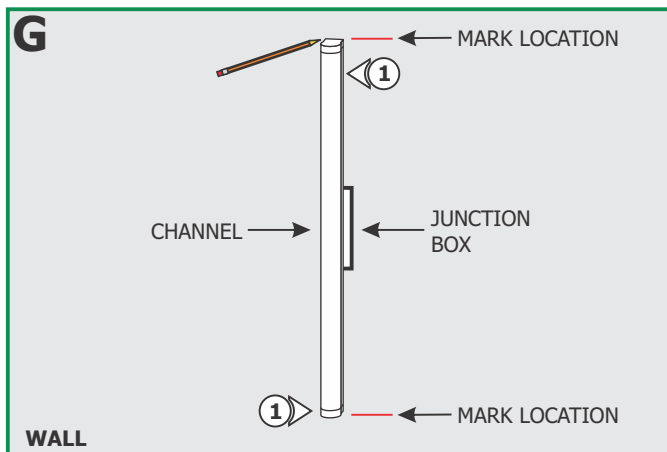

NOTE: It is recommended more than one person to assist in this installation.

NOTE: Fixture can be mounted in a horizontal or vertical position.

NOTE: The junction box does not need to be in middle of the channel (could be at either end) but needs to be aligned in the center of the channel.

1: Mark the wall at each end of the channel and a center line from end to end. **Note which side the wires are located to later install the locking clip to the opposing side.**

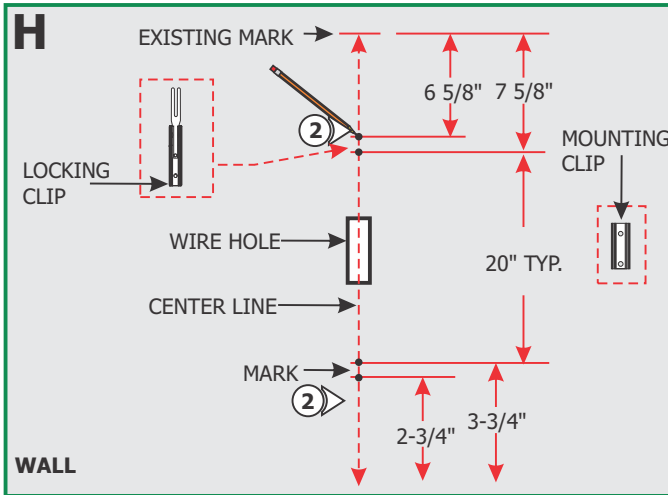

NOTE: TW2-T1-1RE shown for demonstration purposes.

NOTE: Locking clip must be installed in the opposite direction of the fixture wire. Fixtures greater than 36" are provided with two locking clips.

NOTE: The junction box could be offset, but needs to be aligned to the center of the channel.

2: From the two existing marks, make additional marks by following drawing H (a typical suggested location with measurements for the locking clip - longer runs contain two locking clips) to install the locking & mounting clips properly. Mounting clips must be installed every 20" from each other.

NOTE: Steps 3 and 4 are for drywall mounting. Omit these steps if mounting the clips to a wood surface directly.

3: Tap the anchors onto the marked points up to the threaded portion with a hammer.

4: Screw in the threaded portion of the anchors with a Phillips screwdriver.

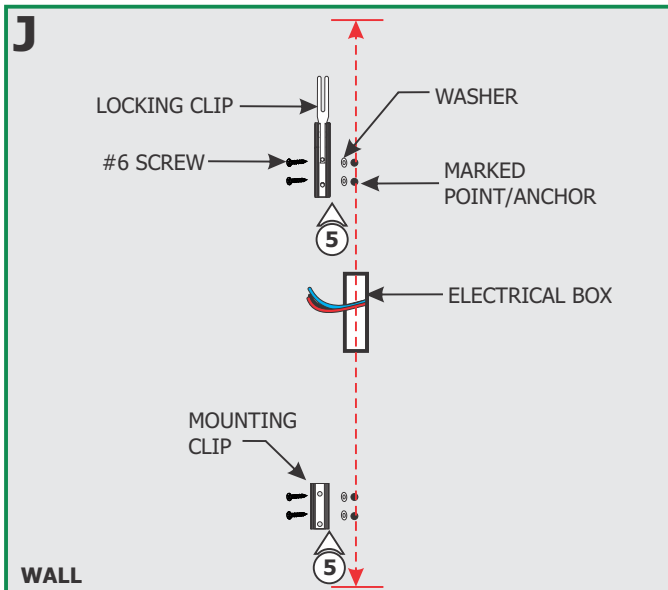
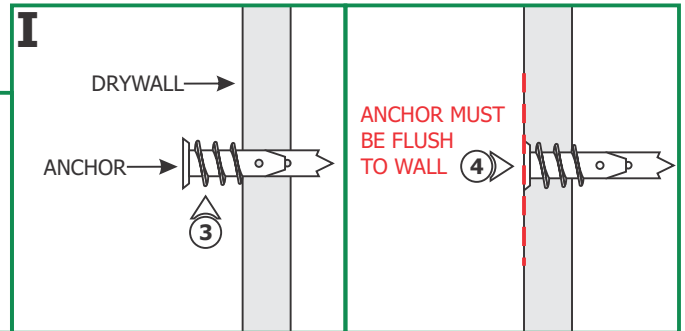

5: Secure the locking clip(s) & mounting clip(s) to the marked surface or anchors by passing the screws through the clip holes followed by the washers into the marked points or anchors. Locking clips mount onto mounting clips.

NOTE: Make sure the power supply wires are present in the junction box.

NOTE: Tighten the screws on the clips until the clips bend inside. This ensures the clips fit properly into the channel.

6: Refer to wiring diagram on pages 7 and 8 to connect the wires properly.

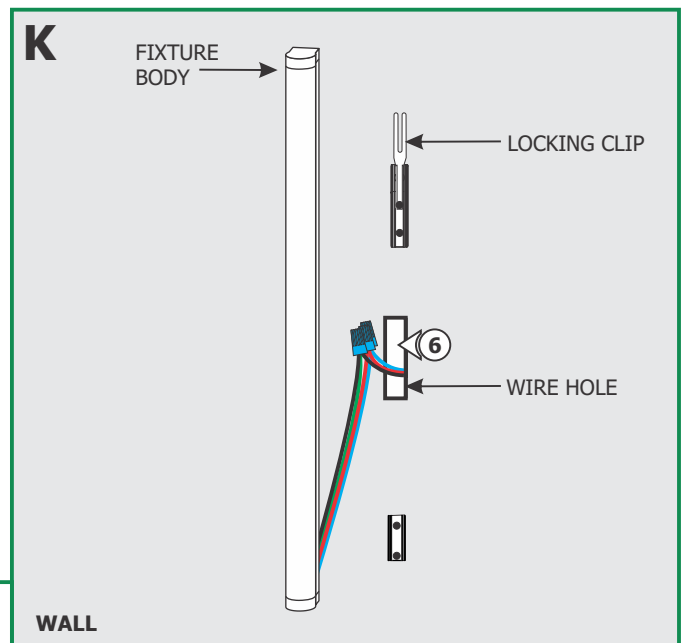

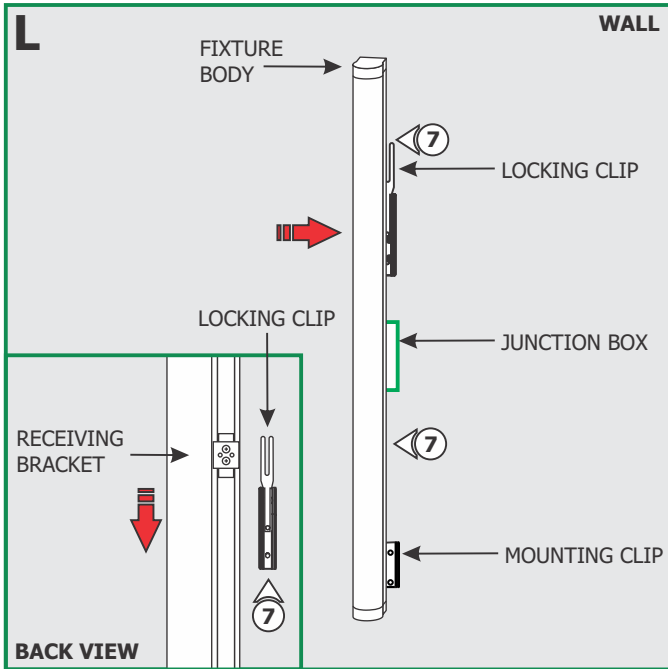

7: Carefully snap fixture body onto the locking & mounting clip(s) then slide into receiving bracket to lock in place. Make sure not to nick the wires.

NOTE: If the receiving bracket interferes with the electrical box, then relocate the bracket by loosening the set screws and make the necessary adjustments.

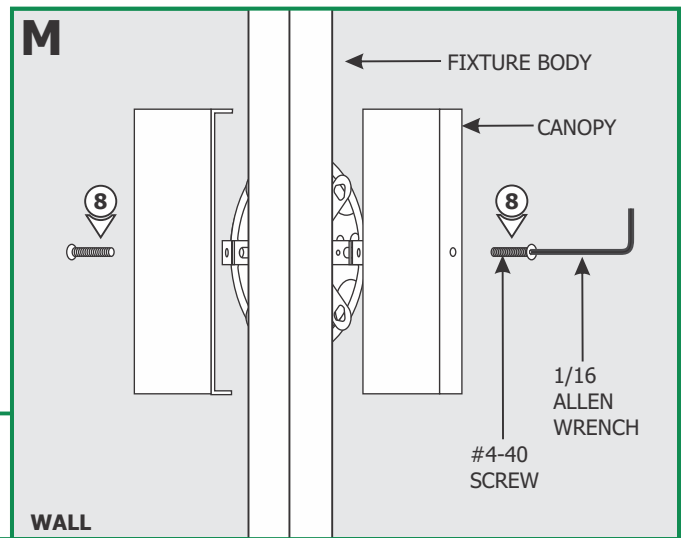

8 (OPTIONAL): For 4" Square Canopy installations, place each canopy piece against the crossbar and secure it to the electrical box holes with the provided #4-40 screws using the 1/16 Allen wrench.

Section Four: Optional Steps For RGB DMX Power Supply

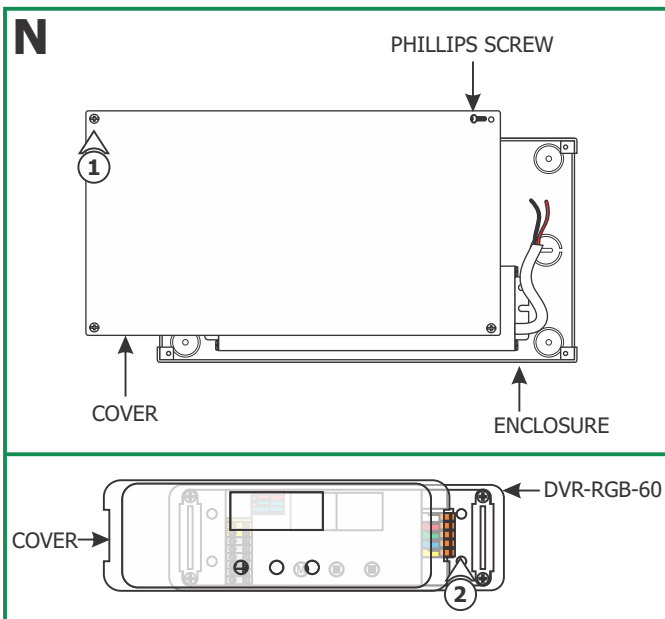

1: Loosen the four Phillips screws on front of the power supply to remove the cover.

2: Carefully pull off the cover from the DVR-RGB-60 driver.

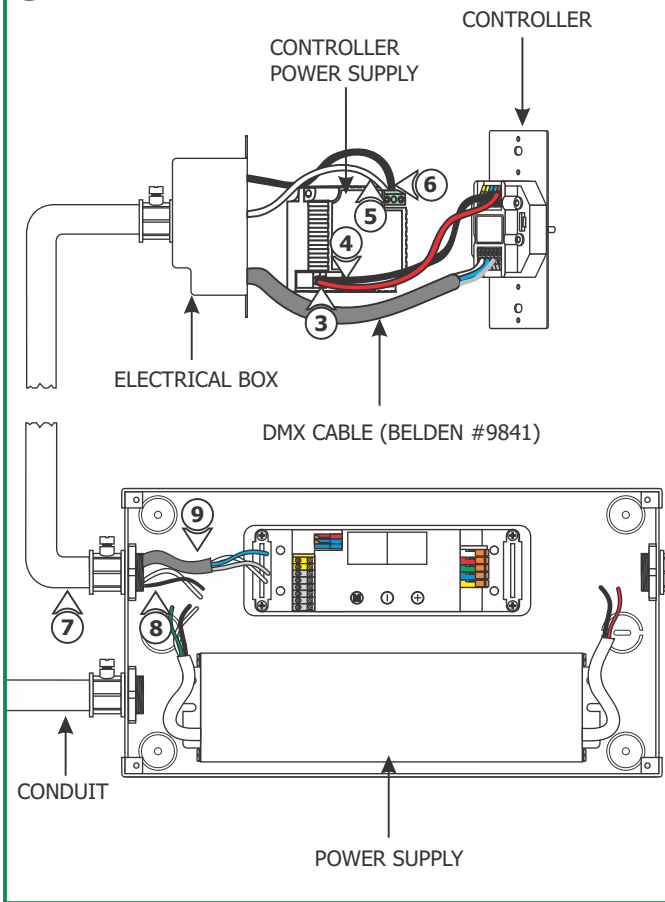
O

NOTE: Use a deep double gang boxes to fit the controller and controller power supply.

NOTE: Refer to the "Configuring and Operating Dim Wheel" on page 9 to properly operate the controller.

- 3: Connect one end of a red wire to the "VDC+" terminal of the controller and the other end to the "+24VDC" terminal of the controller power supply.
- 4: Connect one end of a black wire to the "Ground" terminal of the controller and the other end to the "-24VDC" terminal of the controller power supply.
- 5: Connect the white wire to "N" terminal of the controller power supply.
- 6: Connect the black wire to "L" terminal of the controller power supply.
- 7: Install conduits from the controller, main panel (line voltage), and soft strip to the power supply enclosure.
- 8: Run the black and white line voltage wires coming from the controller power supply to the power supply enclosure.
- 9: Run the proper size DMX cable (**Belden #9841 recommended**) with three data wires from controller to the power supply enclosure.

10: Connect the red wire from the power supply to the "VDC+" DVR-RGB-60 red terminal. Connect the black wire from the power supply to the "VDC-" DVR-RGB-60 blue terminal.

11: Connect one end of a data wire (blue with white stripes wire) to the "LEDSYNC OUT-" controller terminal. Connect the other end into the "DMX in -" DVR-RGB-60 terminal.

12: Connect one end of a data wire (white with blue stripes wire) to the "LEDSYNC OUT+" controller terminal. Connect the other end into the "DMX in +" DVR-RGB-60 terminal.

13: Connect one end of a data wire (bare shield wire) to the "LEDSYNC SHIELD" controller terminal. Connect the other end into the "DMX in shield" DVR-RGB-60 terminal.

NOTE: "DMX in+", "DMX in-", "EXT in+" & "EXT in-", controller terminals are not used on controller.

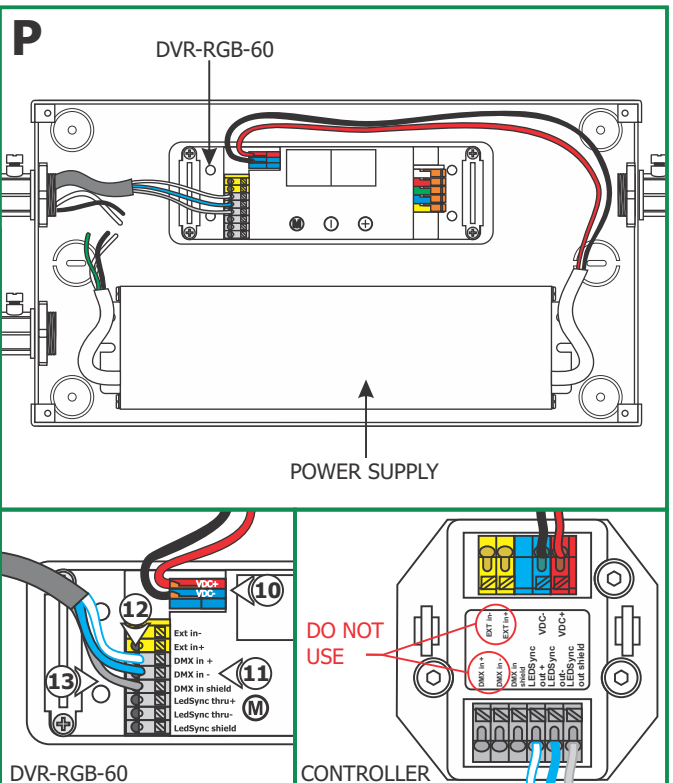

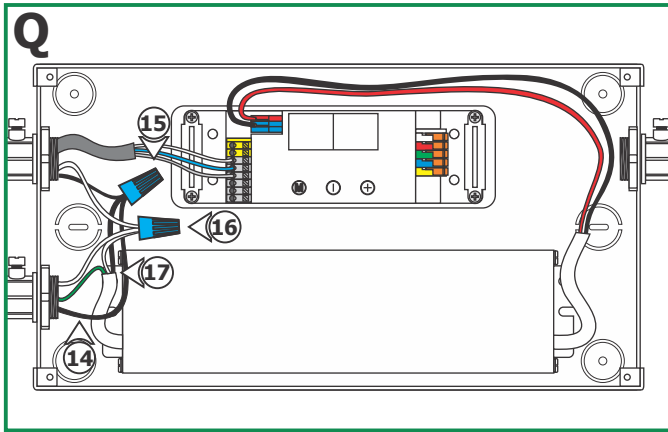

- 14:** Run the line voltage power wires to the power supply enclosure.
- 15:** Connect the hot power wire to the black power supply wire and black controller power supply wire with a wire nut.
- 16:** Connect the neutral power wire to the white power supply wire and white controller power supply wire with a wire nut.
- 17:** Make sure the green power supply wire is grounded in accordance with local electrical codes.

NOTE: The DVR-RGB-60 terminals adapt maximum 18 AWG size. To avoid voltage drop, use 6" of 18 AWG size in RGB terminals connected inline to proper size gauge wire attached to the RGB LED wires with wire nuts. See the "Low Voltage Wire Size Chart" below.

- 18:** Use the "Low Voltage Wire Size Chart" below to determine proper wire size connecting to the DVR-RGB-60 terminals.
- 19:** Run the proper size red, blue, green and black wires from the Twiggly fixture to the power supply case.
- 20:** Connect the black and green fixture wires to the DVR-RGB-60 "LED SUPPLY+" white terminal.
- 21:** Connect the red fixture wire to the DVR-RBG-60 red terminal.
- 22:** Connect the blue fixture wire to the DVR-RBG-60 blue terminal.

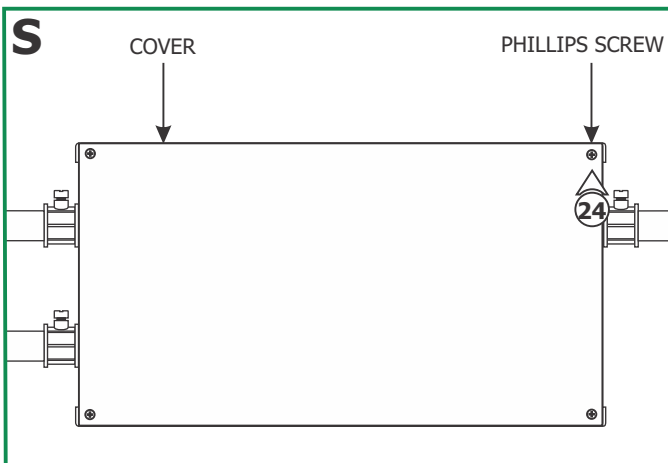
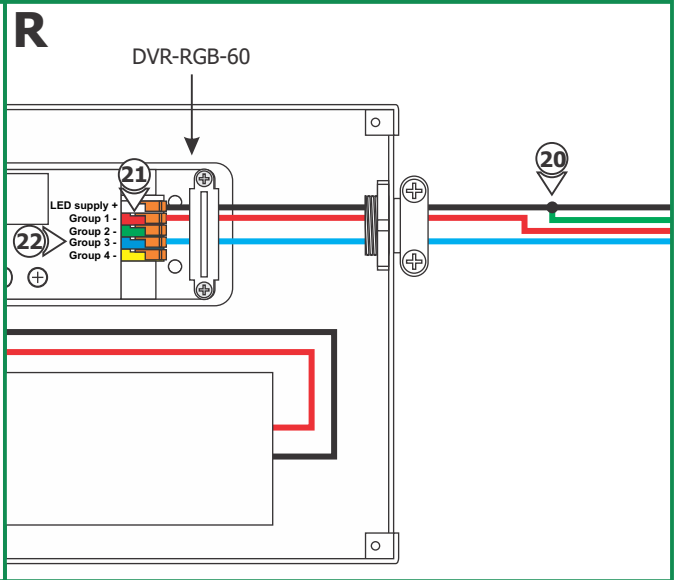

- 23:** Replace the DVR-RGB-60 cover.
- 24:** Replace the power supply cover and secure it by tightening the four Phillips screws.

100W, 24VAC LOW VOLTAGE WIRE SIZE CHART					
3% VOLTAGE DROP	WIRE LENGTH IN FT	UP TO 31FT	32FT-49FT	50FT-81FT	82FT-124FT
	WIRE SIZE	14 AWG	12 AWG	10 AWG	8 AWG
	VOLTAGE AT END OF THE WIRE	23.28 VAC	23.29 VAC	23.28 VAC	23.28 VAC

Configuration 1: RGB Power Supply with DMX Controller

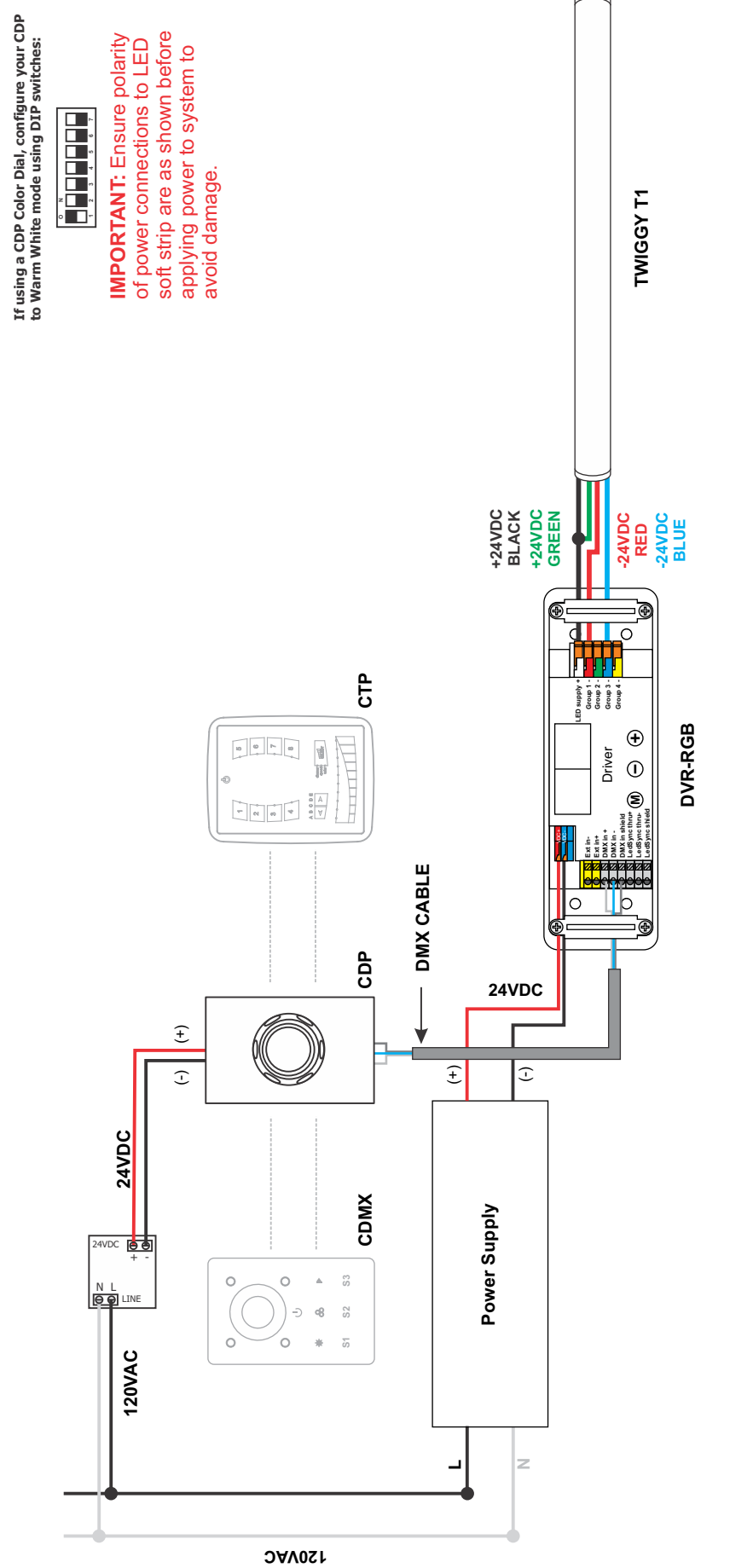

If using a CDP Color Dial, configure your CDP to Warm White mode using DIP switches:



IMPORTANT: Ensure polarity of power connections to LED soft strip are as shown before applying power to system to avoid damage.

Refer to installation instructions included with the DMX controller to set the controller to "CCWW" mode.

Configuration 2: Alternate with Two ELV Dimmers

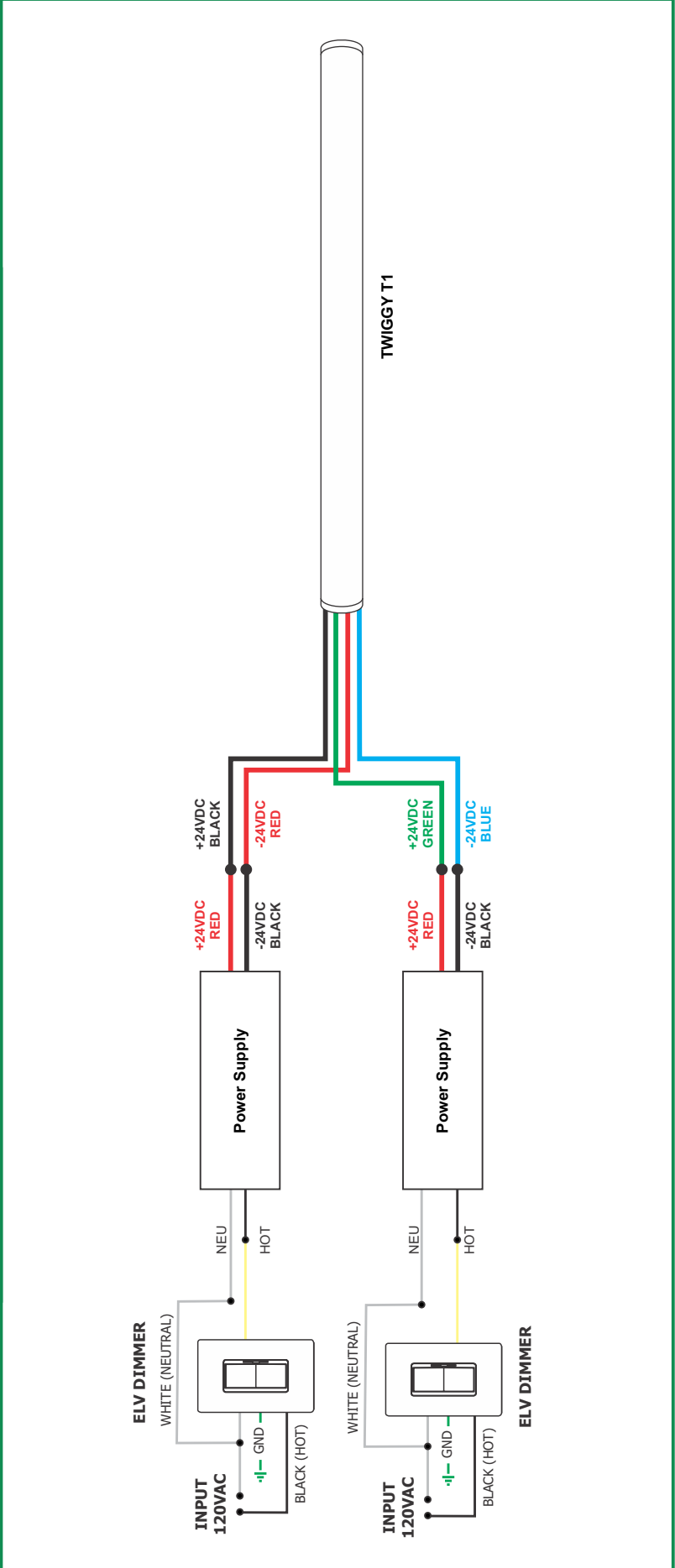

Configuring and Operating Dim Wheel

Selecting Modes

Configure your CDP by setting the DIP switches on the front:



NOTE: The DIP switches must remain accessible after installation. When making changes in the DIP switch settings, disconnect and reconnect the power supply to activate new settings.

Operating CDP

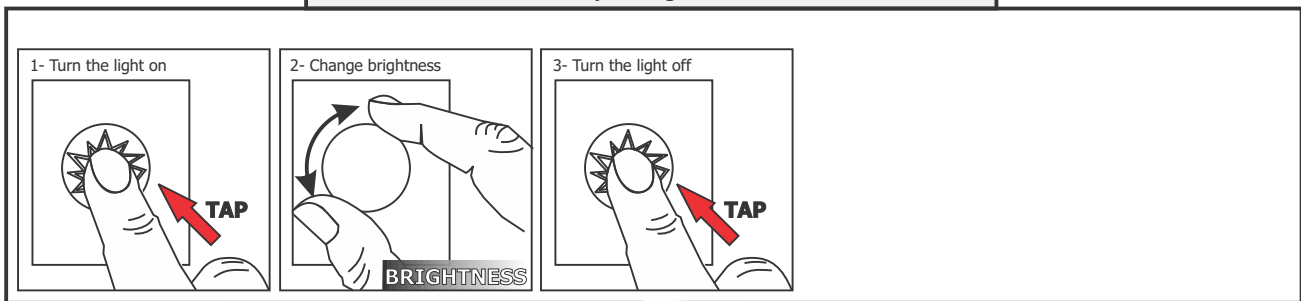

Advanced Operation for Color Mode

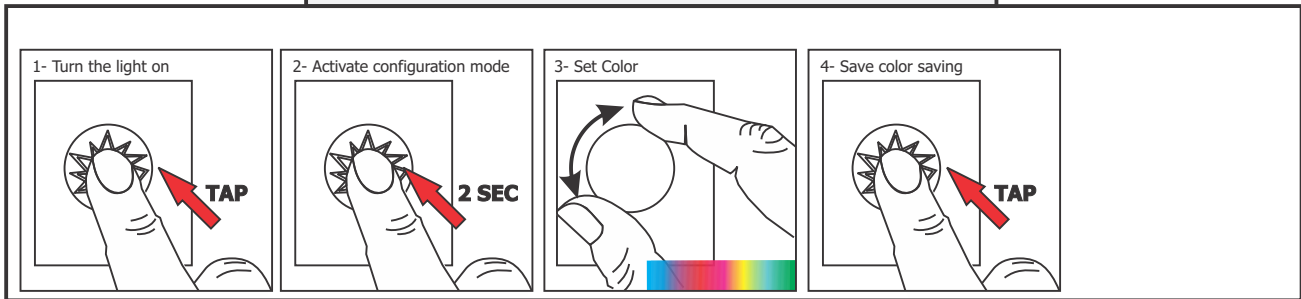

Advanced Operation for Chase Mode

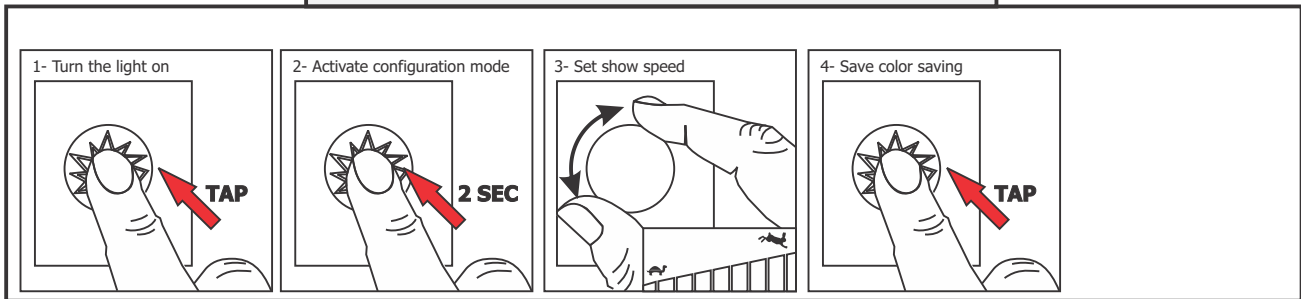

Section Five: Installing Twiggy Fixture on Mirror

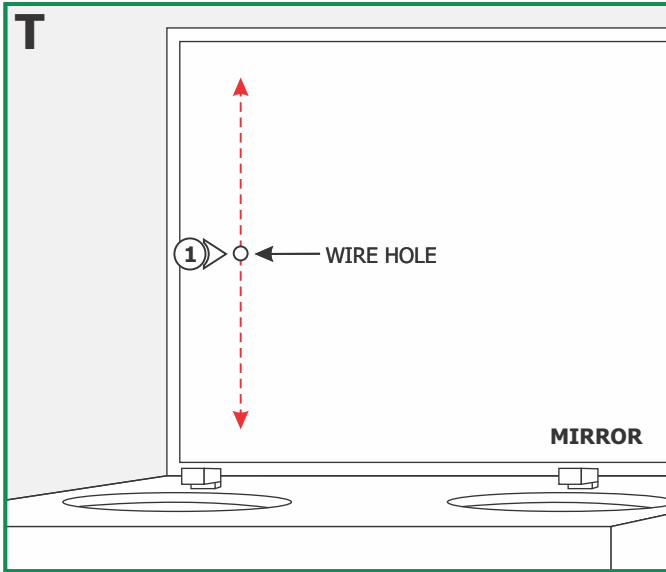

NOTE: It is recommended more than one person assist in this installation.

NOTE: To avoid damage to mirrors, ensure installation is completed by an experienced installer.

NOTE: Fixture can be mounted in a horizontal or vertical position.

NOTE: The junction box can be located anywhere along the length of the fixture but be aligned with the centerline of the channel.

1: Carefully drill a small hole in the mirror to pass low voltage wires through.

NOTE: Locking clip must be installed in the opposite direction of the fixture wire. Fixtures greater than 36" are provided with multiple locking clips.

2: Align and space mounting clips on mirror surface

3: Affix mounting clips to mirror using appropriate adhesive.

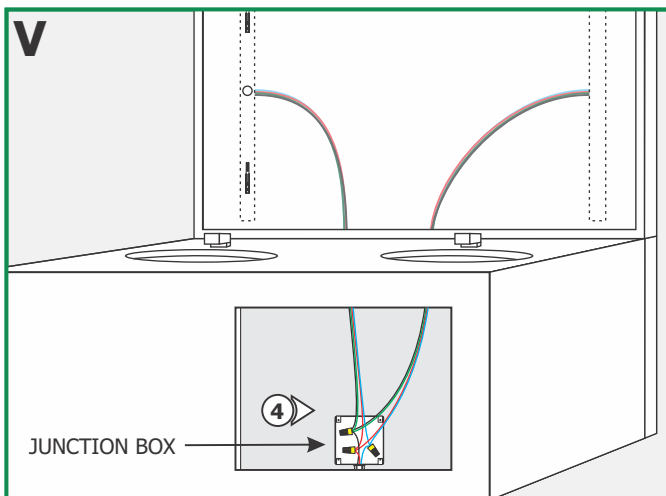
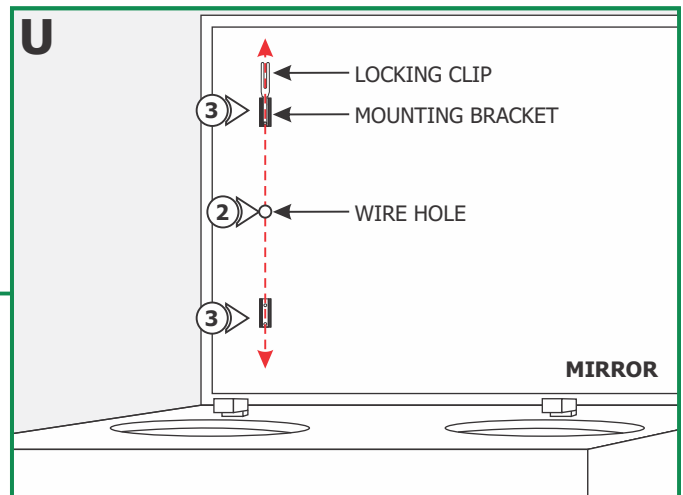

NOTE: (Optional) Junction box can be omitted for special installations or where permitted by local electrical code.

4: Run wires from the DVR to a remote junction box and connect the fixture wires inside the remote junction box.

NOTE: Refer to installation instruction included with dimmer and power supply.

5: Carefully snap fixture body onto mounting clip(s). Slide receiving bracket to lock in place. Ensure low-voltage wires are not damaged during installation.

