



1718 W. Fullerton Ave
Chicago, IL 60614
Tel: 773-770-1195
Fax: 773-935-5613
www.edgelighting.com
info@edgelighting.com

Installation Instructions for **Universo 25 Square**

SAVE THESE INSTRUCTIONS!

GENERAL INFORMATION

- **RISK OF FIRE:** This product must be installed by a qualified electrician. **Turn the power to the electrical box off during installation.** Read the "Important Safety Instructions" before installation.
- This product is suitable only for indoor dry locations and approved for the use at any height above the finished floor.
- This product contains a magnetic transformer with a built-in dimming coil.
- This product may be dimmed only with a low voltage magnetic dimmer. Using a dimmer other than specified may work initially, but will eventually cause transformer failure and void the warranty. The dimmer must be derated as indicated by the dimmer manufacturer.
- A typical installation is shown. Specific installation must be in accordance with the local electrical codes.
- Load the circuit of the surface mount transformer to **MAXIMUM 150 Watt.**

IMPORTANT SAFETY INSTRUCTIONS

- Do not install this lighting system in a damp or wet location.
- Do not conceal or extend bus bar conductor through building wall.
- To reduce the risk of fire and burns, do not install this lighting system where the insulated open bus bar conductors can be shorted or contact any conductive materials.
- To reduce the risk of the system overheating and possibly causing a fire, make sure all the connections are tight.
- Do not install fixture assemblies closer than six inches, or as specified in the fixture installation instructions, to curtains or similarly combustible materials.
- Turn the electrical power off before modifying the lighting system in any way.
- Minimum volume of the electrical box must be 6 cubic inches (98 cubic centimeters).

Install the Surface Mount Transformer

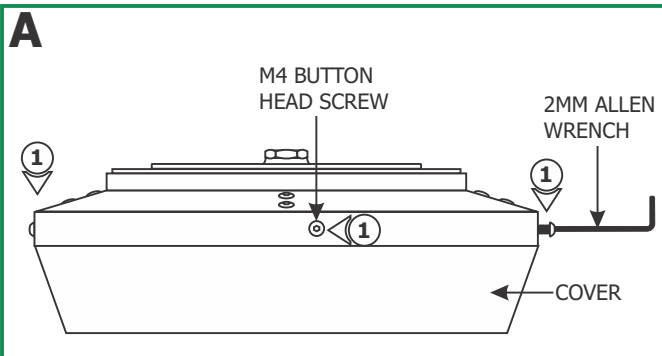

- 1:** Loosen and remove the five M4 button head screws around the transformer cover with the provided 2mm Allen wrench.

- 2:** Unhook the transformer cover from the set screw and remove it from the transformer housing.

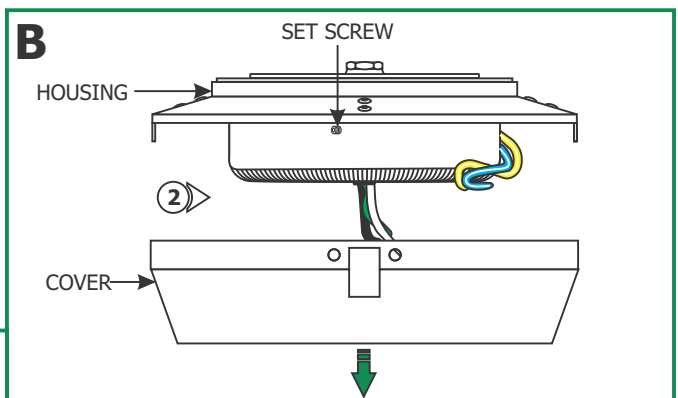

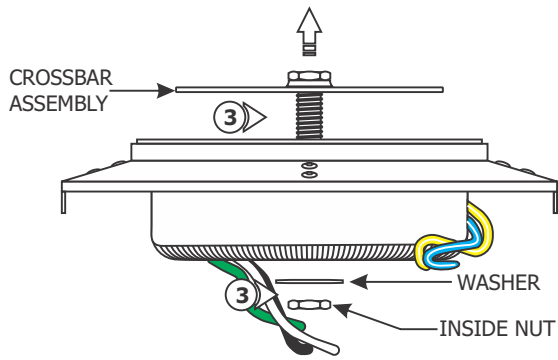
C

3: Remove the inside nut and washer to remove the crossbar assembly. **DO NOT DISASSEMBLE THE CROSSBAR ASSEMBLY.**

4: Connect the provided white and black extension wires to the neutral and hot power wires respectively with the wire nuts provided.

5: Feed the wires through the crossbar assembly nipple.

6: Place all wires and wire nut connections inside the electrical box.

7: Mount the crossbar assembly to the electrical box with the two provided #8-32 screws.

8: Make sure the crossbar assembly is grounded in accordance with local electrical codes.

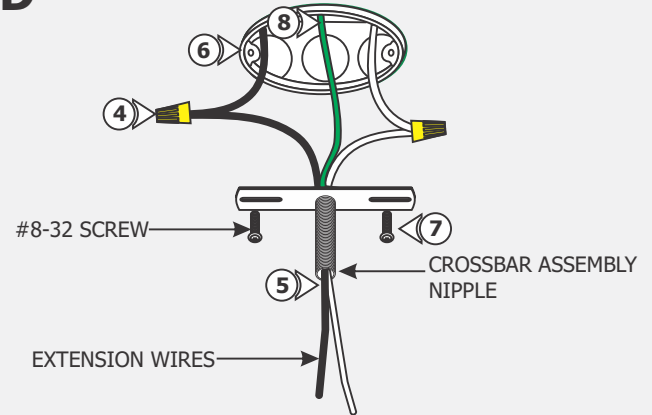
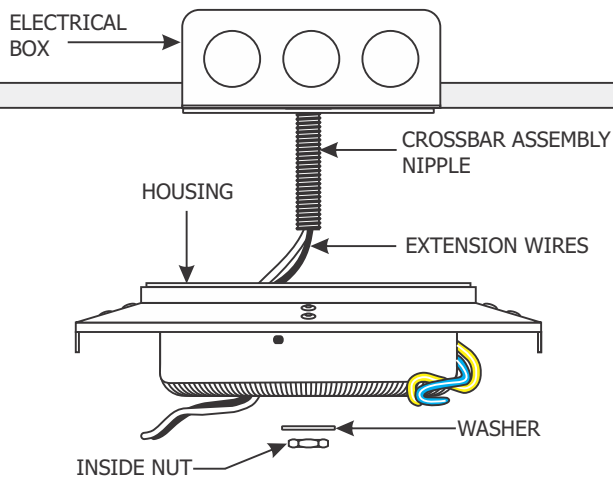
D**E**

9: Feed the extension wires through the transformer housing center hole. Slide the transformer housing onto the crossbar assembly nipple and secure it in place by tightening the washer and inside nut.

10: Feed power cables through holes in cover.

11: Strip 1/2" of the outer plastic insulation from both power cables.

11: Connect the negative power cable to the black wire from the power supply using a wire nut.

12: Connect the positive power cable to the white wire from the power supply using a wire nut.

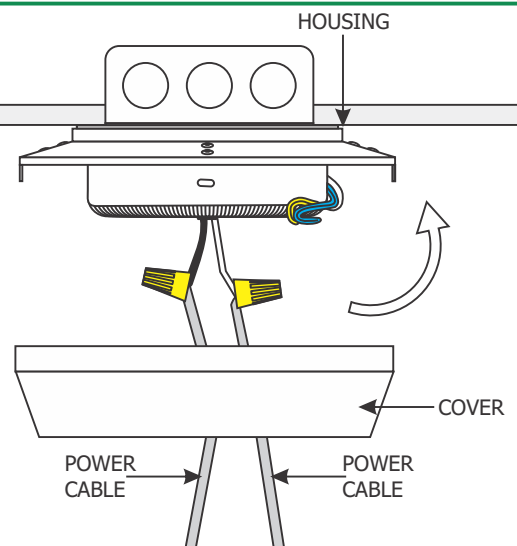
F

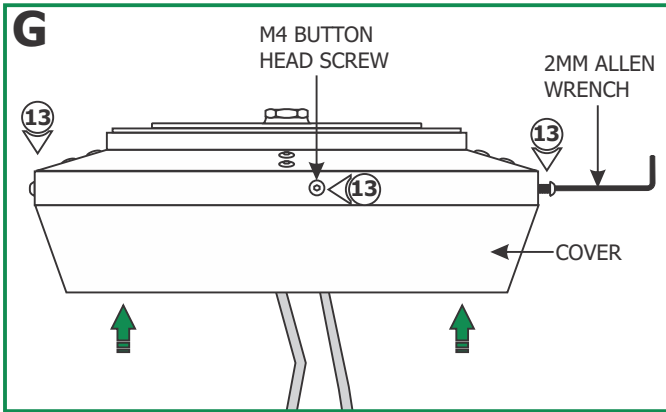

13: Replace the cover and tighten the five M4 button head screw around the transformer cover with the provided 2mm Allen wrench.

Install Standoffs

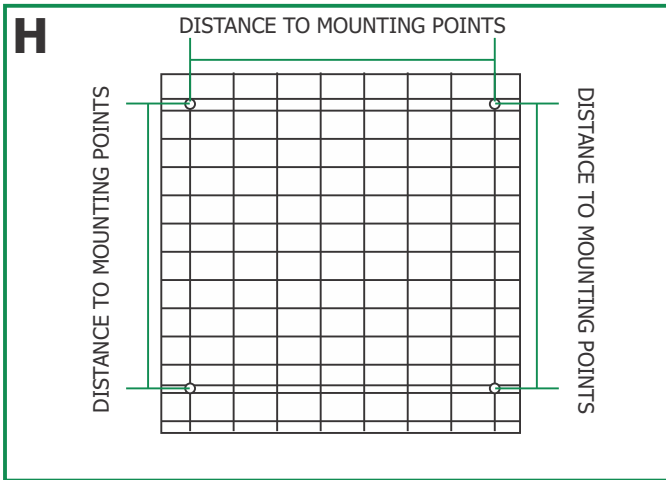

1: Measure the distance between the mounting points of the fixture.

2: Mark out the measurements on the ceiling or use a plumb bob to mark the standoff locations onto the ceiling (this may require more than one person).

3: Tap the anchors onto the marked locations up to the threaded portion with a hammer.

4: Screw in the threaded portion of the anchors with a Phillips screwdriver.

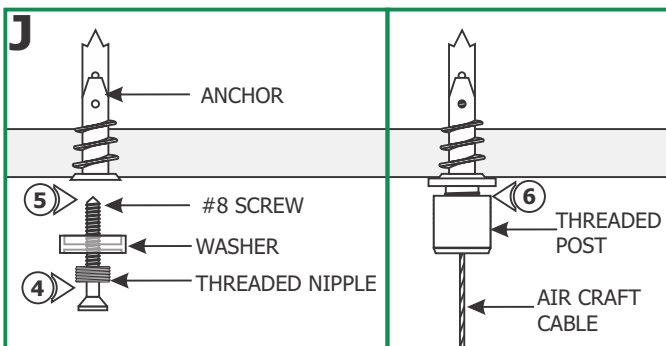
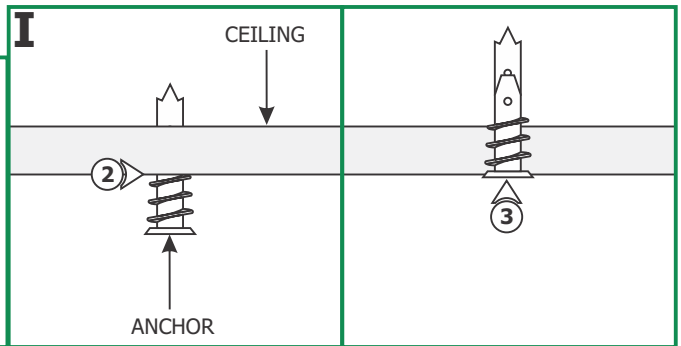

5: Feed the #8 screw through the countersunk side of the threaded nipple and washer. **Make sure the side of the washer with deeper countersunk is facing the anchor.**

6: Tighten the #8 screw completely into the anchor.

7: Tighten the threaded post completely onto the threaded nipple.

8: Repeat steps 4 through 6 for the remaining standoffs.

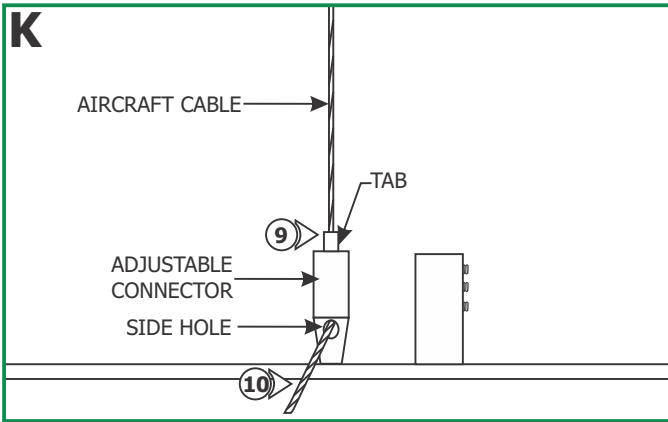

9: Push the tab on the adjustable connector and feed the aircraft cable through the top of the tab.

10: Pull the aircraft cable coming out of the side of the adjustable connector. Release the tab to lock the adjustable connector in place.

11: Repeat steps for the remaining standoffs.

- 12:** Strip the end of both power cables.
- 13:** Insert the negative power cable into the power standoff marked negative.
- 14:** Tighten the Allen set screws in the power standoff to secure the power cable.
- 15:** Insert the positive power cable into the power standoff marked "positive".

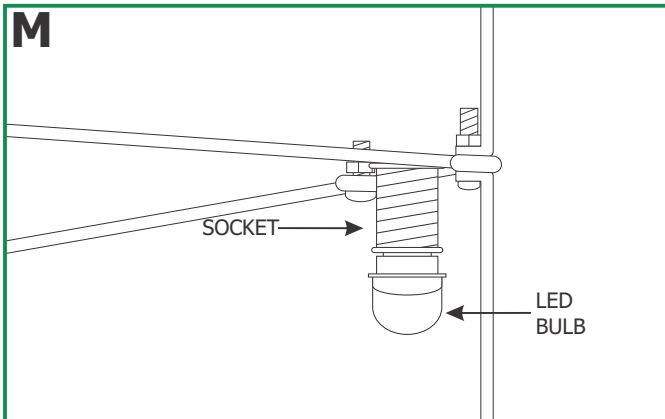
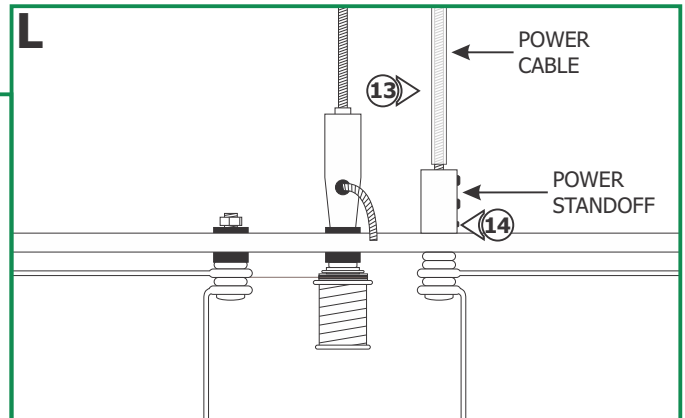

16: Install LED bulbs into each socket

17: Carefully install the glass rods by seating them into the mounting hooks. Ensure the mounting hardware is fully seated in the mounting hooks.

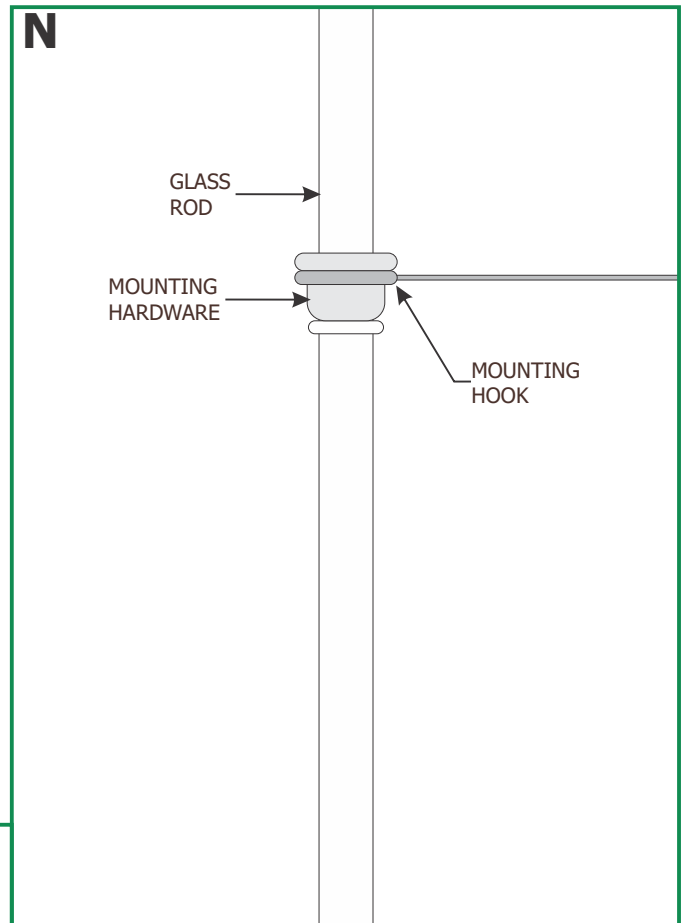



1718 W. Fullerton Ave
Chicago, IL 60614
Tel: 773-770-1195
Fax: 773-935-5613
www.edgelighting.com
info@edgelighting.com

Installation Instructions for **Universo Square 41**

SAVE THESE INSTRUCTIONS!

GENERAL INFORMATION

- **RISK OF FIRE:** This product must be installed by a qualified electrician. **Turn the power to the electrical box off during installation.** Read the "Important Safety Instructions" before installation.
- This product is suitable only for indoor dry locations and approved for the use at any height above the finished floor.
- This product contains a magnetic transformer with a built-in dimming coil.
- This product may be dimmed only with a low voltage magnetic dimmer. Using a dimmer other than specified may work initially, but will eventually cause transformer failure and void the warranty. The dimmer must be derated as indicated by the dimmer manufacturer.
- A typical installation is shown. Specific installation must be in accordance with the local electrical codes.
- Load the circuit of the surface mount transformer to **MAXIMUM 2x250 Watt.**

IMPORTANT SAFETY INSTRUCTIONS

- Do not install this lighting system in a damp or wet location.
- Do not conceal or extend bus bar conductor through building wall.
- To reduce the risk of fire and burns, do not install this lighting system where the insulated open bus bar conductors can be shorted or contact any conductive materials.
- To reduce the risk of the system overheating and possibly causing a fire, make sure all the connections are tight.
- Do not install fixture assemblies closer than six inches, or as specified in the fixture installation instructions, to curtains or similarly combustible materials.
- Turn the electrical power off before modifying the lighting system in any way.
- Minimum volume of the electrical box must be 6 cubic inches (98 cubic centimeters).

Install the Surface Mount Transformer

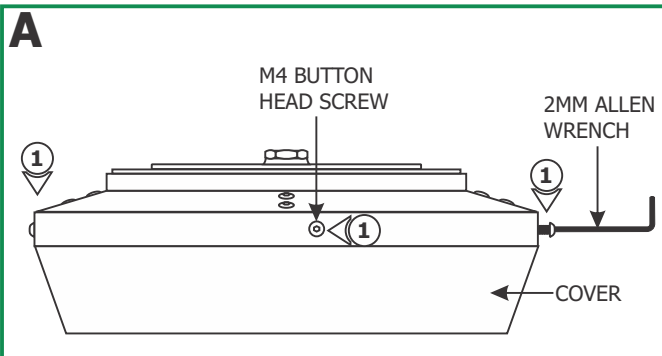

- 1:** Loosen and remove the five M4 button head screws around the transformer cover with the provided 2mm Allen wrench.

- 2:** Unhook the transformer cover from the set screw and remove it from the transformer housing.

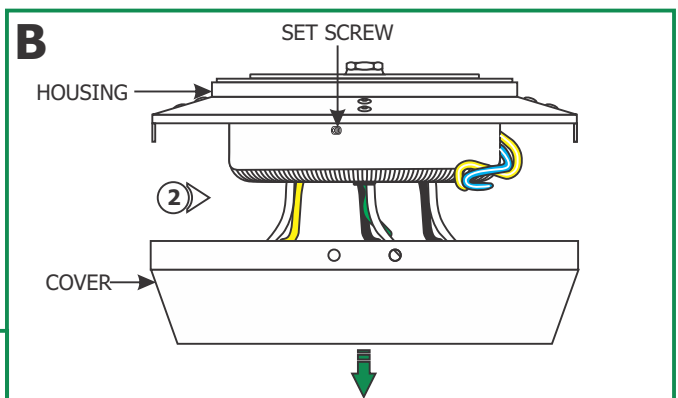

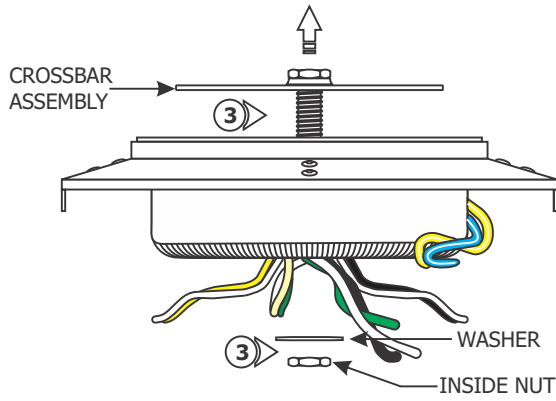
C

3: Remove the inside nut and washer to remove the crossbar assembly. **DO NOT DISASSEMBLE THE CROSSBAR ASSEMBLY.**

4: Connect the provided white and black extension wires to the neutral and hot power wires respectively with the wire nuts provided.

5: Feed the wires through the crossbar assembly nipple.

6: Place all wires and wire nut connections inside the electrical box.

7: Mount the crossbar assembly to the electrical box with the two provided #8-32 screws.

8: Make sure the crossbar assembly is grounded in accordance with local electrical codes.

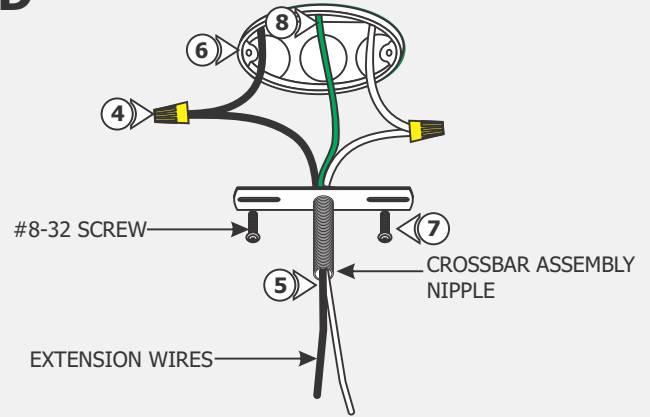
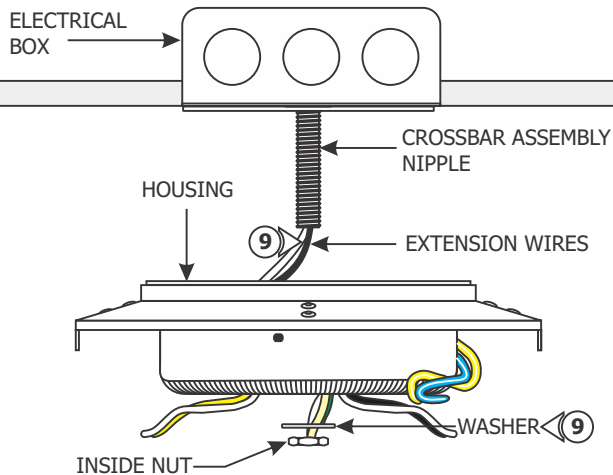
D**E**

9: Feed the extension wires through the transformer housing center hole. Slide the transformer housing onto the crossbar assembly nipple and secure it in place by tightening the washer and inside nut.

10: Connect the white transformer wire to the neutral power wire (**yellow with green stripe**) with a wire nut.

11: Connect the black transformer wire to the hot power wire (**black**) with a wire nut.

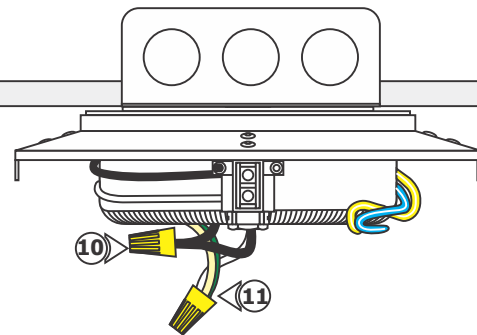
F

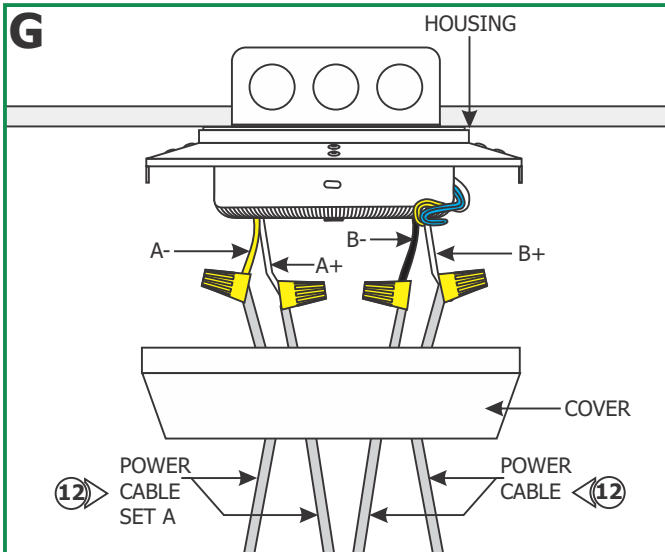

- 12:** Feed power cables through holes in cover.
- 13:** Strip 1/2" of the outer plastic insulation from each power cable.
- 14:** Connect one power cable from Power Cable Set A to the YELLOW wire labeled "A-" using a wire nut.
- 15:** Connect the other power cable from Power Cable Set A to the WHITE wire labeled "A+" using a wire nut.
- 16:** Connect one power cable from Power Cable Set B to the BLACK wire labeled "B-" using a wire nut.
- 17:** Connect the other power cable from Power Cable Set B to the WHITE wire labeled "B+" using a wire nut.

18: Replace the cover and tighten the five M4 button head screws around the transformer cover with the provided 2mm Allen wrench.

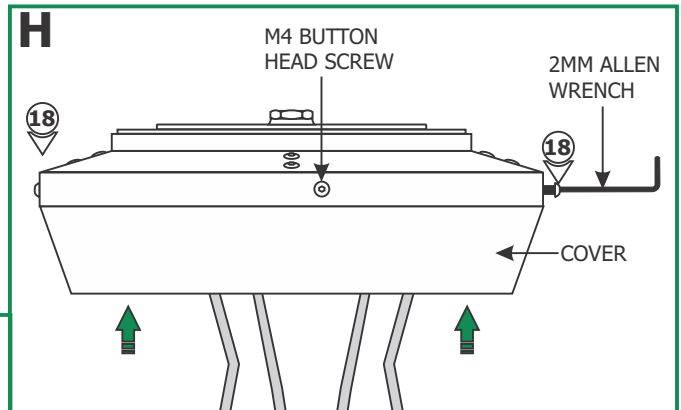

Install Standoffs

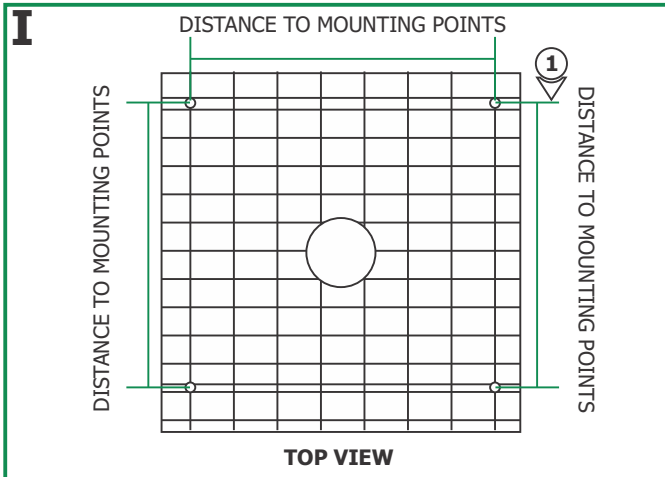

1: Measure the distance between the mounting points of the fixture.

- 2:** Mark out the measurements on the ceiling or use a plumb bob to mark the standoff locations onto the ceiling (this may require more than one person).
- 3:** Tap the anchors onto the marked locations up to the threaded portion with a hammer.
- 4:** Screw in the threaded portion of the anchors with a Phillips screwdriver.

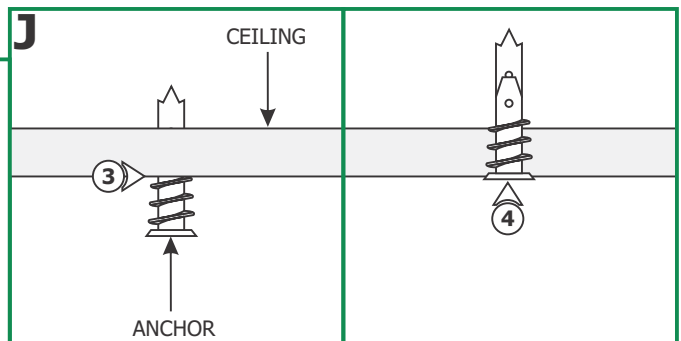

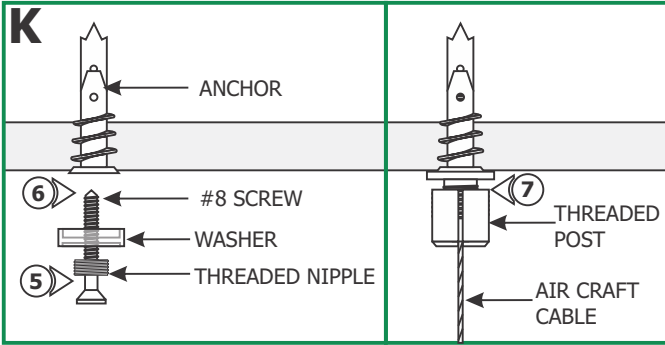

5: Feed the #8 screw through the countersunk side of the threaded nipple and washer. **Make sure the side of the washer with deeper countersunk is facing the anchor.**

6: Tighten the #8 screw completely into the anchor.

7: Tighten the threaded post completely onto the threaded nipple.

8: Repeat steps 4 through 6 for the remaining standoffs.

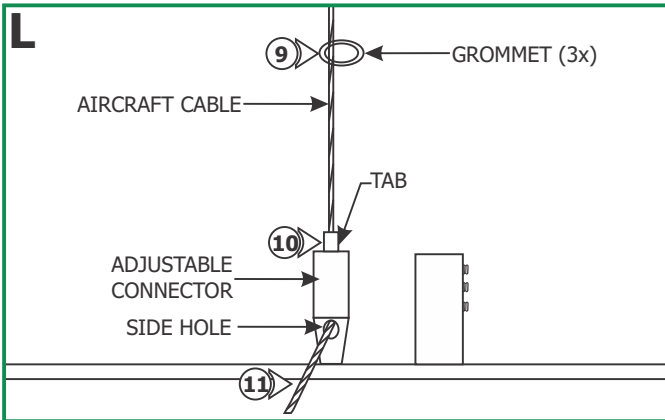

9: Feed each aircraft cable through three of the provided clear plastic grommets.

10: Push the tab on the adjustable connector and feed the aircraft cable through the top of the tab.

11: Pull the aircraft cable coming out of the side of the adjustable connector. Release the tab to lock the adjustable connector in place.

12: Repeat steps for the remaining standoffs.

13: Feed each power cable through the three grommets on each aircraft cable. Align the grommets to secure the power cables to the aircraft cables.

14: Strip 1" of the outer plastic insulation from each power cable.

15: Insert the power cables into the appropriate power standoffs. Each power standoff will be marked to match the power cable markings (i.e. A+ power cable to A+ power standoff).

16: Tighten the Allen set screws in the power standoffs to secure the power cable connections.

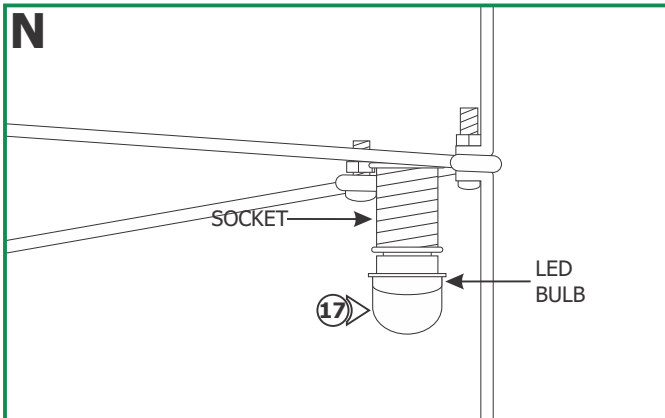
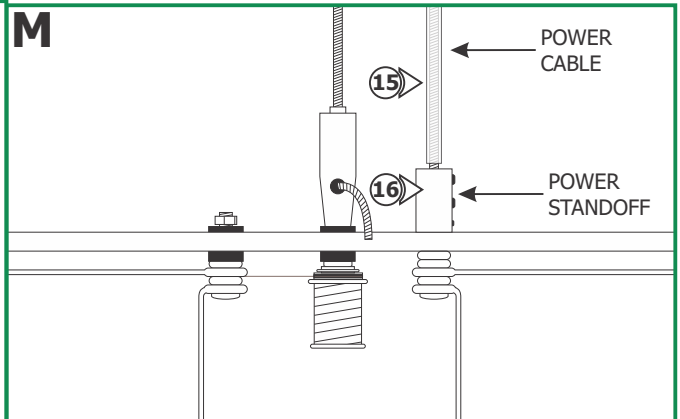

17: Install LED bulbs into each socket (MAX .5W 12VAC LED lamps)

18: Carefully install the glass rods by seating them into the mounting hooks. Ensure the mounting hardware is fully seated in the mounting hooks.

