

LED Aluminum Bullyte (BL616) Specification Sheet

Project Name:	Location:	MFG: Philips Hadco
Fixture Type:	Catalog No.:	Qty:

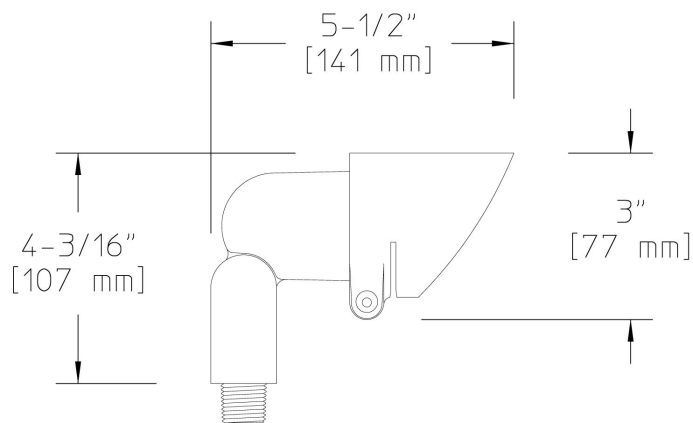

Ordering Guide

Example: BL616 A S7 LED7 NF W

Product Code	BL616	LED Aluminum Bullyte
Finish	A G H	Black Verde Bronze
Mounting	S7	Mounting Stake
Source/Lumens	LED7	7W LED
Optics	NF FL	Narrow Flood Flood
CCT	W	Warm

*2 Fixture will be shipped with lamp. Lamp not sold separately.

Specifications

HOUSING:

Die-cast marine grade aluminum alloy. Fully rotatable shroud, gasketed, die-cast marine grade aluminum alloy. Fully-adjustable swivel arm with vibration-proof locking teeth. 1/2" NPS male threads to screw onto accessory mounting stake or junction box, sold separately. Fasteners are 300 series stainless steel.

FINISH:

Thermoset polyester powdercoat is electrostatically applied after a five-stage conversion cleaning process and bonded by heat fusion thermosetting.

OPTICAL ASSEMBLY:

Clear tempered glass lens.

LAMPING:

7W lamp with 25° or 35° beam spread, 25,000 hours life. Color temperature (CCT): Warm White (3,000K nominal). No Mercury. Dimmable. Approximately 460 lumens.

ELECTRICAL ASSEMBLY:

Bi-pin socket type (GU5.3) with 250° C high temperature teflon coated wire leads. 12 Volt fixture is pre-wired with 3-ft pigtail of 18-2 AWG, 105° C, SPT-1W wire. Low voltage quick connector, catalog #LVC3 included for easy hook-up to the low voltage supply cable, not included. 12 Volt system requires remote transformer, not included.

WARRANTY:

Five-year limited warranty.

CERTIFICATIONS:

ETL listed to U.S. safety standards for wet locations. cETL listed to Canadian safety standards for wet locations. Manufactured to ISO 9001:2008 Standards.

Width:

3" (77mm)

Length:

5 1/2" (141mm)

Max. Weight:

1.04 lb