

PHILIPS

100 Craftway, P.O. Box 128
Littlestown, Pennsylvania 17340-0128
Phone: 800-331-4185 Fax: 717-359-9672

INSTALLATION INSTRUCTIONS: MICRO UNDERWATER

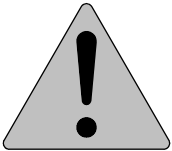
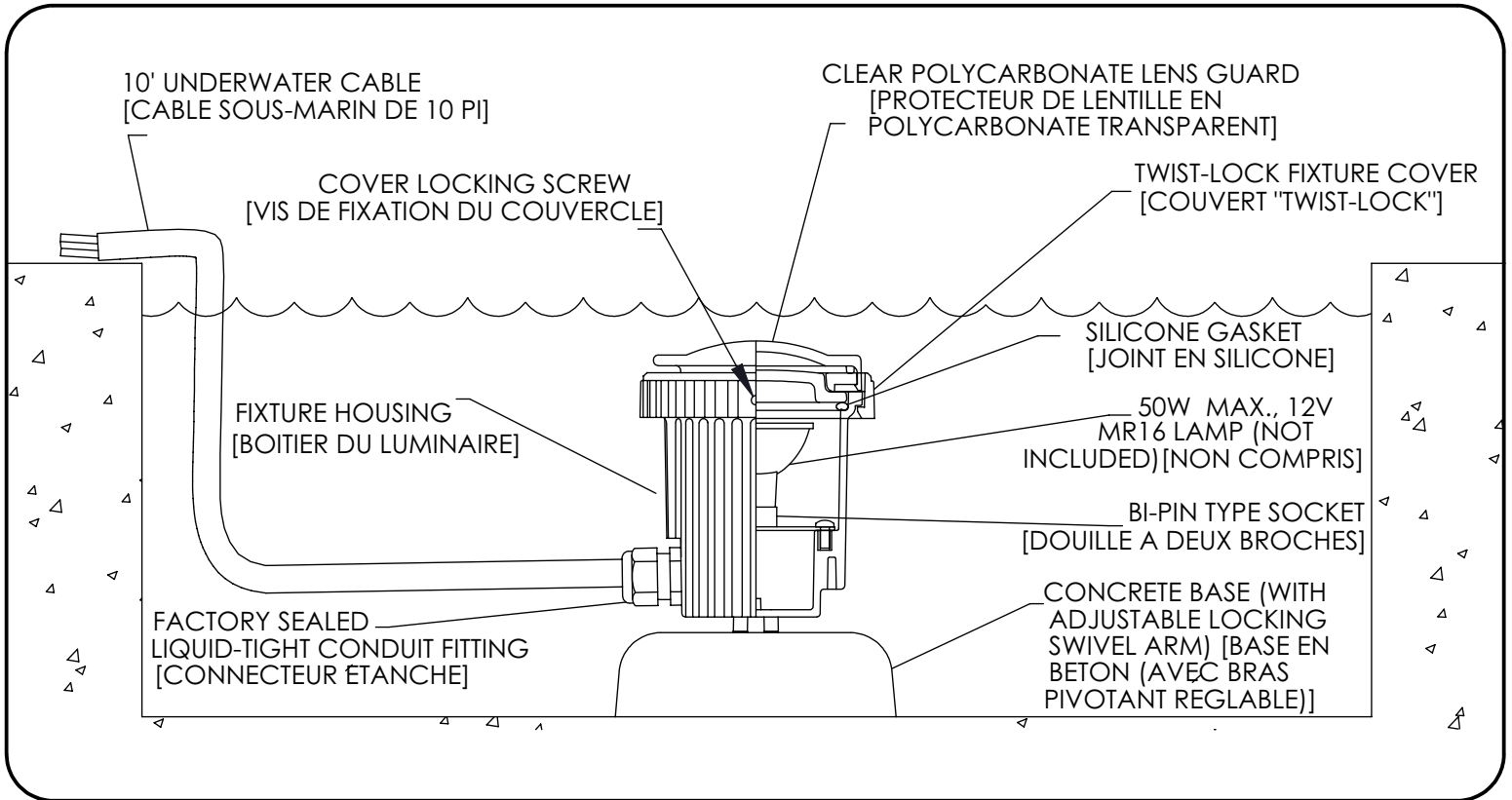

This fixture is intended for installation in accordance with the National Electrical Code and local code specifications. Failure to adhere to these codes and instructions may result in serious injury and/or damage to the ballast and void the warranty. These instructions do not purport to cover all details or variations in equipment, nor to provide for every possible contingency related to installation, operation, maintenance, or mounting situation. Should specific problems occur that are not addressed by these instructions, contact your Sales Representative or distributor for assistance. Retain these instructions for future reference.



SAFETY WARNING:

ALWAYS TURN FIXTURE OFF/DISCONNECT POWER AND ALLOW TO COOL BEFORE PERFORMING ANY MAINTENANCE, INCLUDING RELAMPING AND CLEANING!

This fixture can become very HOT! The fixture housing and lens, especially if it is glass, can become hot enough to blister hands. Attention should be paid to where the fixture is mounted, particularly if it can be touched by children or pets. To help prevent premature failure, decreased performance, overheating and risk of fire, keep fixture and lens clean and free of leaves, mulch, debris and mineral deposits from water. The fixture and lens can be cleaned using a soft cloth and a solution of mild liquid soap and warm water. Wipe clean and dry with a soft, lint-free dry cloth. Avoid polishing fixture or lens.



INSTRUCTIONS PERTAINING TO A RISK OF FIRE OR INJURY TO PERSONS IMPORTANT SAFETY INSTRUCTIONS - SAVE THESE INSTRUCTIONS!

WARNING - Lamp gets HOT quickly! To reduce the risk of FIRE OR INJURY TO PERSONS:

Do not operate fixture with a missing or damaged lens/lens assembly.

Contact only switch or plug when turning fixture on or off. Do NOT touch hot lens or housing.

Turn off or unplug fixture and allow to cool before relamping. Keep lamp away from combustibles.

Do NOT touch lamp with bare hands at any time, use a soft cloth as oil from skin may damage lamp.

CAUTION!

1. TO PREVENT ELECTRICAL SHOCK, DISCONNECT TRANSFORMER FROM ELECTRIC SUPPLY BEFORE SERVICING.
2. DO NOT let the fixture freeze. This may cause cracking or deformation that may cause the fixture to leak, or cause safety problems.
3. DO NOT hold fixture by or pull the underwater cable. If wire is pulled it may break the liquid-tight seal and void the warranty.
4. DO NOT use the fixture out of water with the polycarbonate lens guard on. If the fixture is not used as an under-water fixture, remove the clear polycarbonate lens guard or it will distort and soften.
5. DO NOT loosen or remove the liquid-tight connector, this will damage the factory set seal and result in possible leakage.
6. The end of the underwater cable MUST BE POTTED to prevent moisture from entering the cable and consequently into the fixture. (See fig. 1).
7. The fixture is to be directly connected to a U.L. LISTED Low Voltage Transformer intended for this application. (See fig. 2).
8. The fixture is rated Max. 50 W, (12) Volt AC, DO NOT connect fixture to any other voltage.

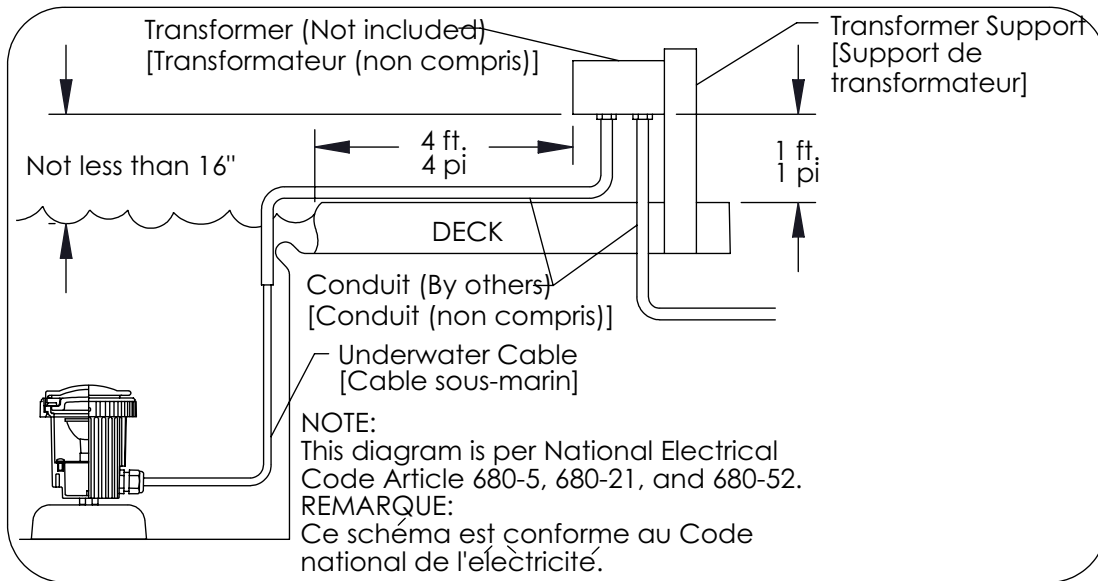

SERVICING INSTRUCTIONS

1. LAMP INSTALLATION / REPLACEMENT:
 - a) Remove the fixture from the water.
 - b) Loosen cover locking screw to remove cover.
 - c) Unscrew the cover by turning it counterclockwise. Remove the lens and O-ring.
 - d) Remove and install lamp. DO NOT exceed the maximum 50 W rating. The lamp is a standard 12V halogen, type MR-16, bi-pin.
 - e) To remove lamp, pull on lamp reflector. Do not pull on the small bulb within the reflector.
 - f) To install lamp, plug the lamp into the bi-pin socket. DO NOT touch the new halogen bulb. Only touch the lamp reflector. Touching the bulb may shorten lamp life.
 - g) The O-ring seating surfaces must be clean. Be certain that the O-ring is in good condition and clean. Reinstall O-ring and lens.
 - h) Reinstall the fixture cover. Look through the (3) slots on cover, hand tighten cover by turning it clockwise until the (3) tabs on cover touch the stops on the housing.
 - i) Tighten the cover locking screw to lock in place.
2. MAKE CERTAIN NO WATER OR MOISTURE IS INSIDE FIXTURE PRIOR TO REASSEMBLING.
3. CLEANING: The lens will require periodic cleaning. Wipe off the outside of the lens with a soft cloth. DO NOT use abrasives. This may damage the lens.

The following lamps may be used in this fixture.
[Ce luminaire peut être pourvu des lampes suivantes.]

20W, MR16, VNSP, 6°
20W, MR16, NSP, 13°
20W, MR16, WFL, 40°
35W, MR16, NSP, 12°
35W, MR16, MFL, 21°
35W, MR16, WFL, 35°
42W, MR16, NSP, 9°
42W, MR16, MFL, 20°
42W, MR16, WFL, 36°
50W, MR16, NSP, 12°
50W, MR16, MFL, 24°
50W, MR16, WFL, 38°