



Project: \_\_\_\_\_

Fixture Type: \_\_\_\_\_

Location: \_\_\_\_\_

Contact/Phone: \_\_\_\_\_

# 8" SQUARE IC HOUSING

INCANDESCENT LAMPS

**IC6**

## PRODUCT DESCRIPTION

IC Double wall housing construction • Can be completely covered with insulation.

## PRODUCT SPECIFICATIONS

**Lamp** One 60W A19 lamp.

**Socket** Medium base porcelain with nickel-plated copper screw shell.

**Trims** Trim selection shown on reverse.

**Labels** UL listed for through-branch wiring, damp locations and IP • Product thermally protected against improper use of lamps • Union made • UL Listed/CSA certified.

**Testing** All reports are based on published industry procedures; field performance may differ from laboratory performance.

Product specifications subject to change without notice.

## INSTALLATION

**Real Nail 3 Bar Hangers** Telescoping, Patented (US Patent D552,969) Real Nail® 3 system permits quick placement of housing anywhere within 24" O.C. joists or suspended ceilings • Integral T-bar notch and clip secures housing in suspended ceiling grid – no accessory clips required • 24" expansion stop allows quick placement of fixture in standard grid spacing • Bars scored in two locations for fast, clean breaking, allowing housing installation in tight applications • Bars captive to mounting frame • Edge-mounted for extra strength • Captive bugle-headed ring shank nail for quick one-step installation and easy removal with claw hammer for fixture relocation • Quick-Loc slot and oversized locking set screw lock fixture in position • Bar hanger foot contoured to align to bottom of construction joist • Alternate mounting holes included.

**Junction Box** Pre-wired junction box provided with (5) ½" and (1) ¾" knockouts, (4) Romex connectors and ground wire, UL listed/CSA certified for through-branch wiring, maximum 8 No. 12 AWG 90° C branch circuit conductors (4 in, 4 out) • Junction box provided with removable access plates • Knockouts equipped with pryout slots.

**Mounting Frame** 22-gauge die-formed galvanized steel mounting frame • 13½" L x 9¾" W, (excluding bar hangers) • Rough-in section (junction box, mounting frame, housing and bar hangers) fully assembled for ease of installation.

**Housing** IC housing, .032" aluminum • Access door for junction box accessibility • Housing is vertically adjustable to accommodate up to a 1" ceiling thickness.

## DIMENSIONS

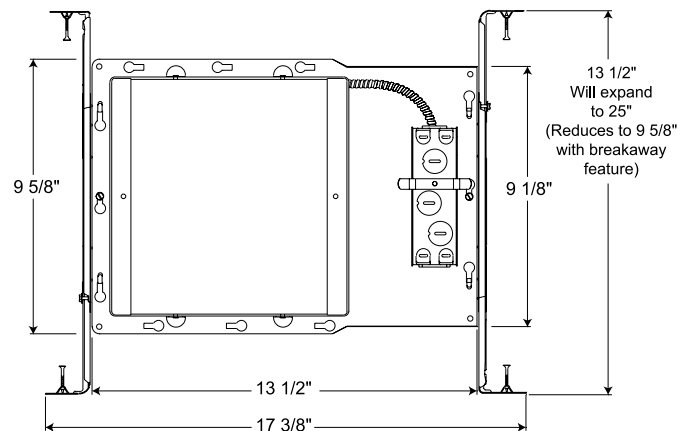
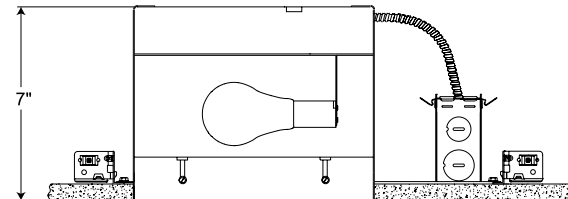

8 5/8" SQ. CEILING CUTOUT

## PRODUCT CODES

Catalog Number	Input Voltage	Lamp Rating (max.)
IC6	120V	60W A19

# 8" SQUARE IC HOUSING

INCANDESCENT LAMPS

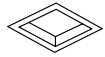
**IC6****TRIMS/LAMPS**

Cat. No.	Description	Lamp Rating
60-WH	Crystal Diffuser	60W A19

Trim Size: 9 $\frac{1}{8}$ " SQ.  
Trim Finish: WH - White.