



Lapa

MODERN FAN COMPANY
Customer Service
M-F 8am - 4pm (PST)

(ph) 888.588.3267
www.modernfan.com

Lapa Fan- Installation instructions

Should you have any questions or difficulty installing your new fan, please contact Modern Fan Co. customer service immediately.

Note: Power supply must be turned off prior to any contact with electrical wires. It is recommended that a licensed electrician be hired to install your ceiling fan.

(1) Remove and identify contents of carton.

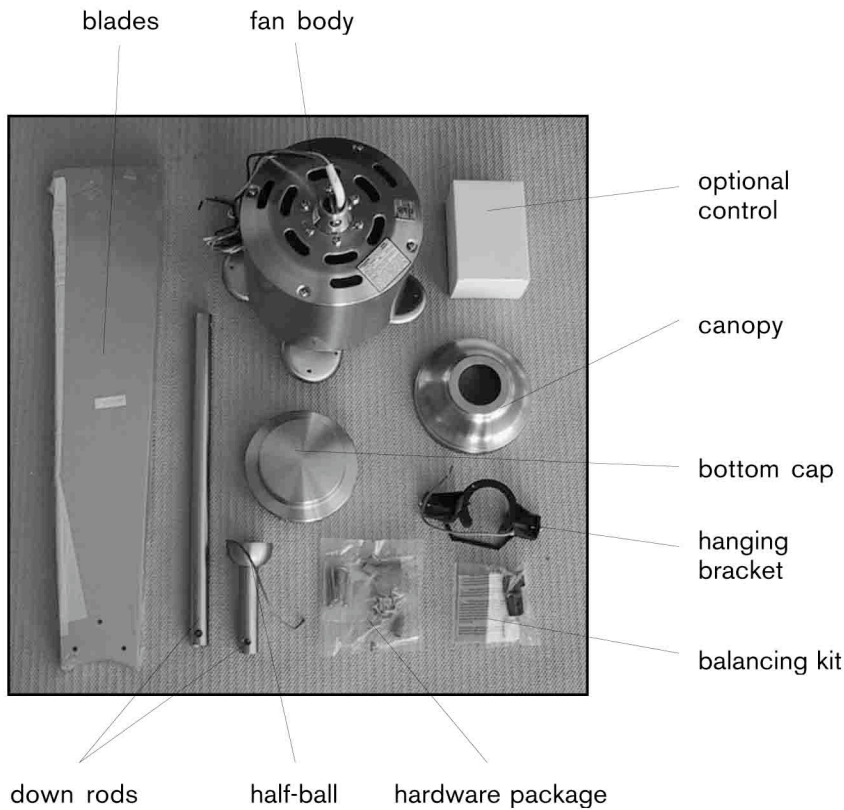

(2) Using machine screws from hardware package or existing screws in junction box, securely attach hanging bracket to ceiling junction box.



(3) Remove the stopper screw and loosen the set screw on the fan collar. Set the stopper screw aside for step **(5)**.

set screw
stopper screw

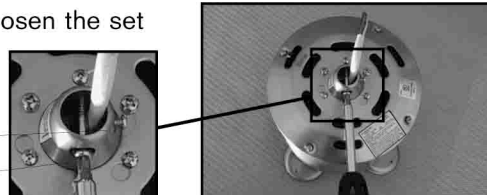

(4) Remove stopper pin and half ball from small down rod by loosening set screw on half ball. Set all parts aside for steps **(5)** and **(7)**.

set screw
stopper pin

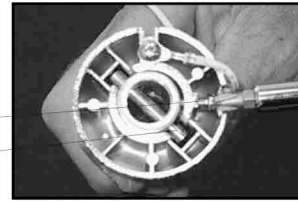

(5) Run fan wires through selected down rod. Reinstall stopper screw from step **(3)** and firmly tighten set screw on fan collar against down rod.

Note: If ceiling height allows, using a longer down rod will increase airflow and efficiency.



(6) Slide fan canopy over down rod and carefully rest on top of fan body.

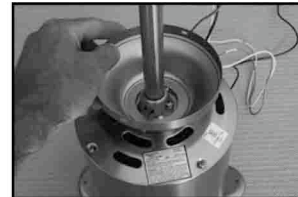

(7) Reinstall half ball on end of down rod. Be sure that stopper pin is inserted through down rod and seated in half ball. Tighten set screw against down rod.

set screw
stopper pin

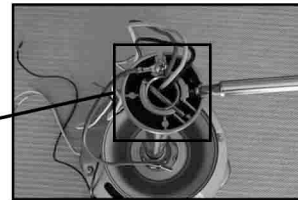

(8) Lift fan to ceiling and set half ball in the hanging bracket so that the ridge on the edge of the hanging bracket is seated in the slotted channel in the half ball.

channel and ridge



With fan safely suspended by bracket, make wire connections with wire nuts included in hardware package as described in the control installation instructions. If using the optional #003 or #004 control, the receiving unit should be placed inside the arms of the hanging bracket and connected at this time.

(9) Remove set screws on the sides of the hanging bracket. Lift canopy to ceiling. With holes in side of canopy aligned with set screw holes on hanging bracket, reinstall set screws to hold canopy in place.

set screw



(10) Insert one blade into rotor slot. Using blade screws from hardware package, secure blade to blade arm. Start all three screws before completely tightening. Repeat for all blades.



(11) Attach bottom cap to fan body by aligning slots on cap with fittings inside fan body, and rotating clockwise, or proceed to step **(12)** if you are using the optional light kit.



(12) To install optional light kit, begin by identifying all parts, then follow steps **(a)** through **(f)** below:

socket screws

globe

socket

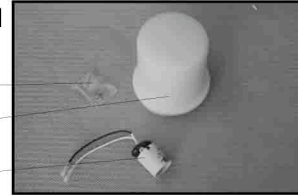

(a) Remove inner cup from fan body.



(b) Attach socket to inner cup and run wire leads through center hole.

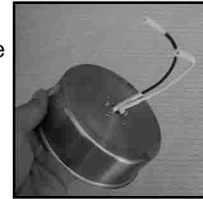

(c) Snap together wire leads from fan body to wires from socket. Reinstall inner cup.



(d) Install standard light bulb (75 watt max.). Not included.



(e) Identify three channels in glass globe to align with fittings on inner cup.

channel

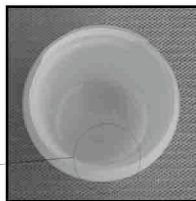

(f) Aligning channels and fittings, rotate glass globe in the clockwise direction until securely in place.

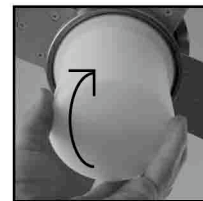

(13) Install control as described in the control installation instructions.

(14) Your fan is reversible for summer and winter operation. The reverse switch is located on top of the fan body. The LEFT position is for summer and the RIGHT position is for winter.

reverse switch



(15) The rotor and motor of your fan have been dynamically balanced at the factory. In addition, the blades have been matched to the nearest gram to ensure a well balanced ceiling fan. Furthermore, a blade balancing kit has been included with your fan. Please refer to the instructions packaged with the balancing kit should your fan require additional balancing.



Flush Mount Kit

MODERN FAN COMPANY
Customer Service
M-F 8am - 4pm (PST)

(ph) 888.588.3267
www.modernfan.com

Flush Mount Kit- Installation Instructions

Should you have any questions or difficulty installing your new fan, please contact Modern Fan Co. customer service immediately.

Note: Power supply must be turned off prior to any contact with electrical wires. It is recommended that a licensed electrician be hired to install your ceiling fan.

Note: These instructions replace steps **(2)** through **(9)** of the Lapa Fan Installation Instructions. However, you will need to refer to the Lapa Fan Installation Instructions to complete your installation.

(1) Identify Flush Kit parts:

ceiling plate

canopy

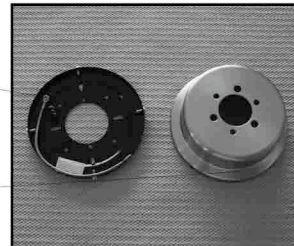

(2) Remove six screws around top of fan body. Take note of two sizes of screws and locations.



(3) Using screws from step **(2)**, attach the canopy to fan body.



(4) Using the existing screws from your junction box, or the machine screws from the fan hardware package, secure the ceiling plate to ceiling junction box. The electrical wires must be accessible through the hole in the center of the ceiling plate.



(5) Remove two of the set screws from the ceiling plate opposite one another and set aside for step (7). Loosen the other two without removing them from the plate.

loosened set screws

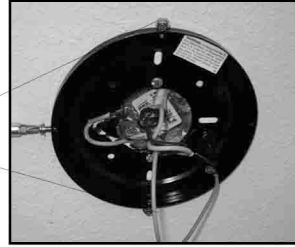

(6) Lift fan body and hang from ceiling plate hook. The hook should go through one of the closed holes in the canopy.

hook through canopy hole



With fan safely suspended by hook, make wire connections with wire nuts included in fan hardware package as described in the control installation instructions. If using the optional #003 or #004 control, the receiving unit should be connected at this time and placed inside the canopy.

(7) Carefully lift fan off hook and align open holes/slots on canopy with the two set screws that remain partially in the ceiling plate. Twist the fan so the these two set screws hold it in place. Reinstall the additional two set screws through the closed holes in the canopy and into the ceiling plate . Tighten all four screws firmly.



Refer to the Lapa Fan Installation Instructions to complete installation of the blades, bottom cap, and/or the optional light.

Modern Fan / Period Arts Fan Controls

Our ceiling fans do not use conventional pull chains (with the exception of the Industry model). When ordering your fan, you should have selected the control that was most appropriate for your fan and electrical requirements. Third party controls are generally compatible but must be FAN SPEED CONTROLS with specific speed settings. Continuous, variable speed controls or rheostats are not compatible with our fans, are likely to cause motor noise and will void your ceiling fan warranty.

Control options are as follows:



#001- Fan Speed Control

A basic fan control used to operate a fan only, providing four speeds. Can be used in combination with a separate light switch/dimmer in a double-gang wall box to control a fan with light.



#002/002ND- Three Wire Fan Speed & Light Control

Intended for operation of a fan with light. Requires two circuits (three wires). #002 provides four speeds and full range dimming; #002ND (for fluorescent lights) provides three speeds and on/off switching of light.



#003- Handheld Remote Control

Designed for independent operation of a fan and light using only one circuit (two wires). Provides three speeds and full range dimming (for halogen or incandescent lamps) or "on/off" switching (for fluorescent lamps) and comes with a wall hanging bracket.



#004- Two Wire Fan Speed & Light Control

Designed for independent operation of a fan and light using only one circuit (two wires). Provides three speeds and full range dimming (for halogen or incandescent lamps) or "on/off" switching (for fluorescent lamps) and wires into wall box.



#005- Two Wire Wall Control with Remote Handset

A combination control package including our #004 Fan & Light Control and our #003 Remote Control handset. Provides three speeds and full range dimming (for halogen or incandescent lamps) or "on/off" switching (for fluorescent lamps) from wall control and compatible remote handset.



#009A/009B- Multi-Fan Speed Controls

A three speed fan control designed to control two fans (#009A) or three to five fans (#009B) on a single circuit. Separate control/switching of lights must be planned for if this control is to be used for fans with lights.

Installation Instructions: With power turned off at breaker, make wire connections from the fan to the power supply at the ceiling and from the control to power at wall box as shown in the wiring diagrams below. Your fan may have dedicated neutral wires for the motor (WHITE) and for the light (ORANGE) or may have a common neutral (WHITE only). **Note:** For #009A or #009B, refer to printed instructions included in control box/packaging.

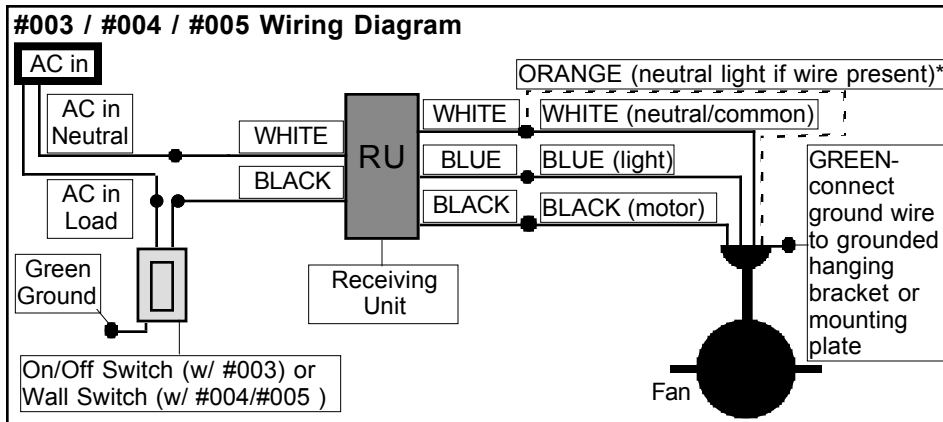
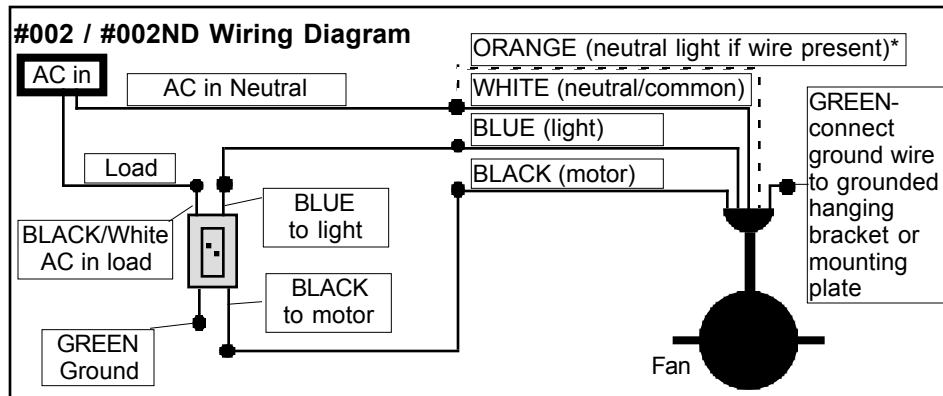
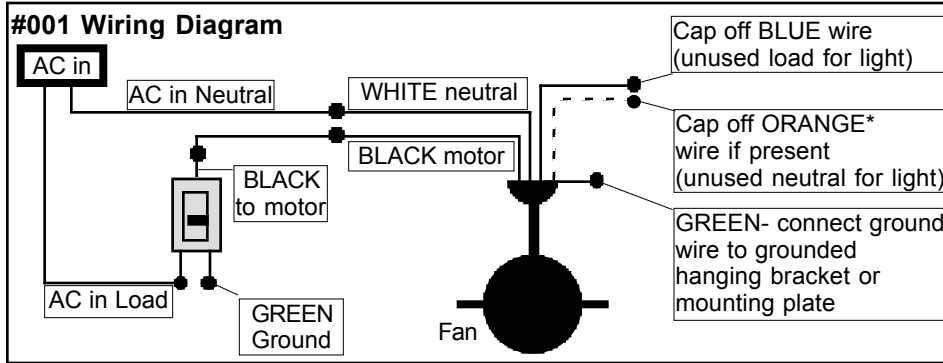

* Your fan may have dedicated neutral wires for the motor (WHITE) and for the light (ORANGE) or may have a common neutral (WHITE only).

#003, #004 and #005 Receiving Unit Wiring Instructions:

With fan suspended from ceiling and with power off at breaker box, make wire connections as shown below. The receiving unit sits in the ball hanging bracket of most models as pictured (a), or in the upper portion of the fan body in Huger fans, Stratos, Eclipse and Pensi models (b) and (c).

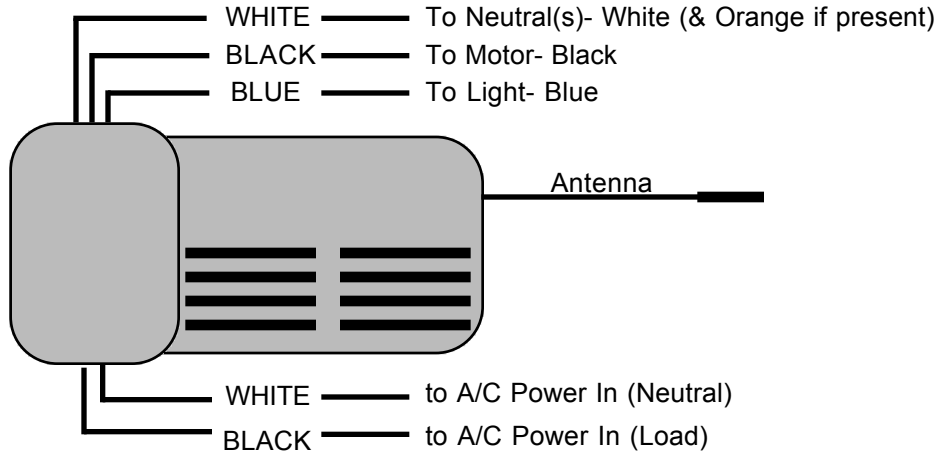

Receiving Unit Placement:

While there is ample room for the receiving unit as shown here, the wires can sometimes become difficult to manage in the space available. Trimming excess wire before making connections can ease wire management.

Tip: Splicing lighter gauge wire to the power supply and positioning the heavier wires up into the junction box can also ease wire management.

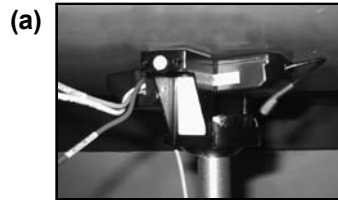
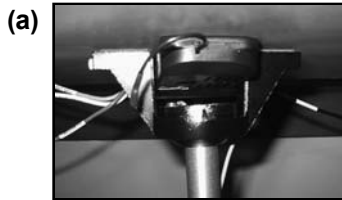

Reminder: Any fan that uses a fluorescent lamp may not be dimmed or operated with a dimming control. A non-dimming version of our #002 (designated by the suffix "ND") is available for use with a fluorescent lamp. For #003/#004/#005, see "Dimming Selection Setting" on next page.

Instructions for Setting Remote Frequency:

The #003/#004/#005 controls use a two or three component system. The wall switch and/or handset is preset to the same frequency as the receiving unit. You may want to change these settings if:

- (a) Other RF signals or appliances are interfering with operation of your ceiling fan.
- (b) You are installing more than one fan in close proximity, and you want to control these fans separately.



Locate the dip switches as pictured to right, and carefully select a new combination of "on" and "off" switches. Within 60 seconds of turning the AC power on, press and hold down the "fan off" button for five seconds. The receiver will then lock in the chosen frequency. Test operation to confirm transmitter and receiver are synced together. If using a handset and wall switch in combination (#005) the dip switches must match.

Dimming Selection Setting (for #003/#004/#005):

Adjacent to the dip switches on the remote handset (for #003/#005) and the wall unit (for #004/#005) as pictured above, there is a *dimming selection switch* which determines whether your control will dim the light or simply turn it on and off. **Note:** any fan that uses a fluorescent lamp may not be dimmed or operated with a dimming control.

The "D" position enables the dimming function while the "ON" position allows for on/off switching only. Do not confuse the "ON" marking for the *dimming selection switch* with the "ON" marking for the four dip switches.

When dimming is enabled, the light button on the face of the control can be pressed and held down to progress through the dimming cycle to the desired light level.

Other Notes and Tips:

- 1) Due to the electronic nature of our #003/#004/#005 controls, it is recommended that power be turned off at the wall location during electrical storms or during long periods of vacancy. This will limit the possibility of damage to the electronic components in the receiving unit.
- 2) All controls are designed for one fan only (except #009A/009B as noted). To control multiple fans with a single remote handset (#003) or wall switch (#004), please consult your dealer or The Modern Fan Co. regarding the purchase of additional receiving units.
- 3) #001, #002 and #009 controls are NOT compatible with the #003 remote control.
- 4) Should you have any questions or difficulty installing your new fan, please contact Modern Fan Co. customer service immediately:

MODERN FAN CO. / PERIOD ARTS FAN CO.

Customer Service
M-F 8am - 4pm (PST)

(ph) 888-588-3267 or 541-482-8545
www.modernfan.com