



1718 W. Fullerton Chicago, IL 60614
 Ph: 773.770.1195 • Fax: 773.935.5613
 www.PureEdgeLighting.com • info@PureEdgeLighting.com
 © 2016 PureEdge Lighting. All Rights Reserved.

Installation Instructions for Fast Jack LED Bubble Pendant

FJ-BBCL27-__

IMPORTANT INFORMATION

- This instruction shows a typical installation.
- This product is ETL listed for indoor dry locations.
- The product is intended to be used with PureEdge Lighting Monorail systems only.

SAVE THESE INSTRUCTIONS!



Adjust the Fixture Height

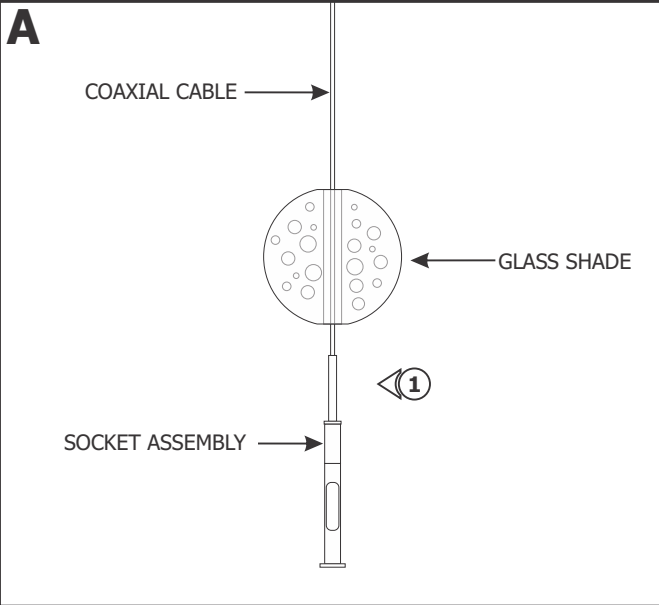

1: Feed the coaxial cable through the glass shade, and rest the glass shade over the socket assembly.

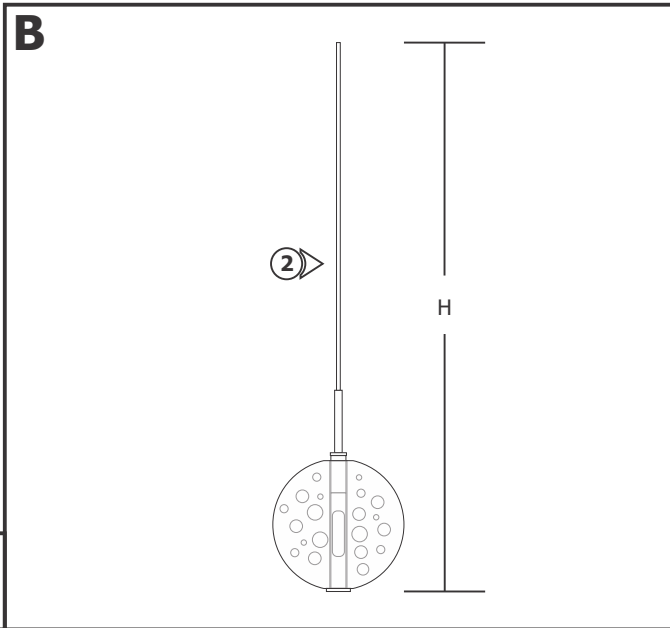

2: Cut the coaxial cable to the desired height (H) with a sharp cutter. The overall fixture height is measured from the bottom of the glass shade to the end of the coaxial cable.

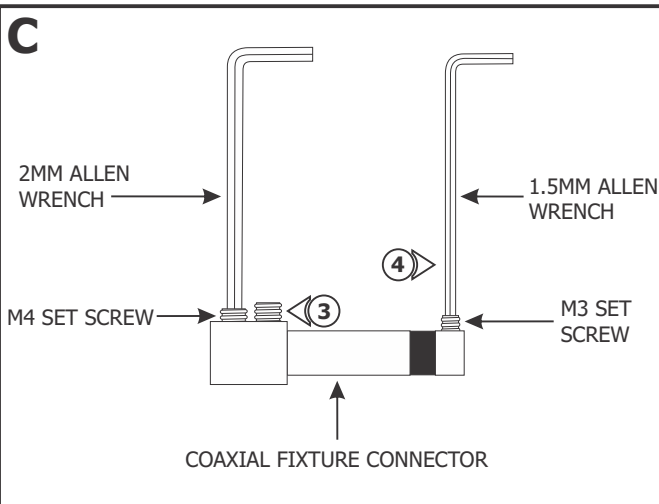

3: Loosen the two M4 set screw on base of the coaxial fixture connector with the 2mm Allen wrench provided. **Do not remove these set screws.**

4: Remove the M3 set screw on tip of the connector with the 1.5mm Allen wrench provided.

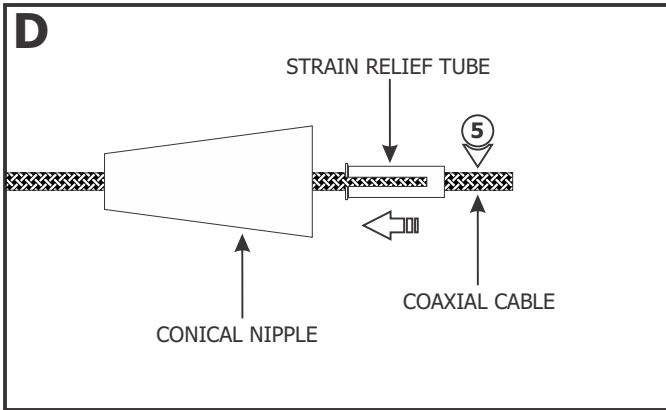

5: Feed the coaxial cable through the conical nipple and flared side of the strain relief tube. Slide the conical nipple and strain relief tube down the coaxial cable.

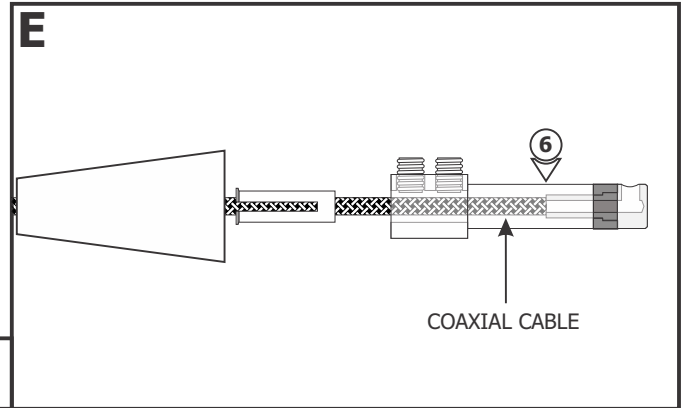

6: Feed the coaxial cable into the coaxial fixture connector. The coaxial cable will come to a stop point.

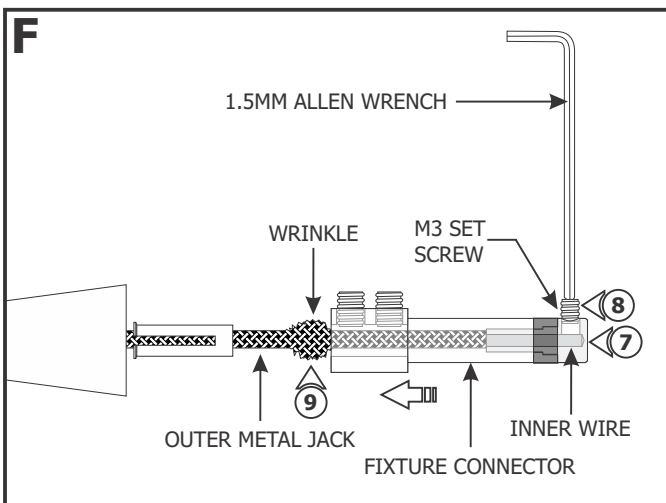

7: Keep feeding the coaxial cable in until the inner wire is visible in the screw hole of the fixture connector tip. The outer metal jacket will start to wrinkle.

8: Hold the fixture connector in place. Replace and tighten the M3 set screw on fixture connector tip with the 1.5mm Allen wrench.

9: Pull down the outer metal jacket to smooth the wrinkles.

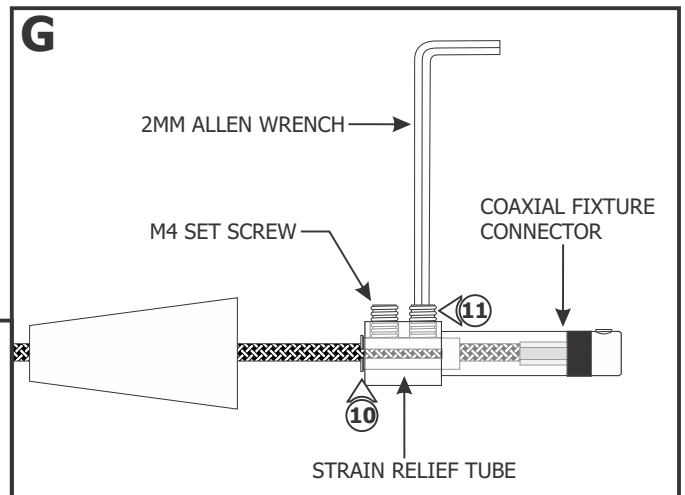

10: Push the strain relief tube completely into the coaxial fixture connector. Make sure the slot on the strain relief tube is not inline with the M4 set screw.

11: Tighten the two M4 set screws with the 2mm Allen wrench.

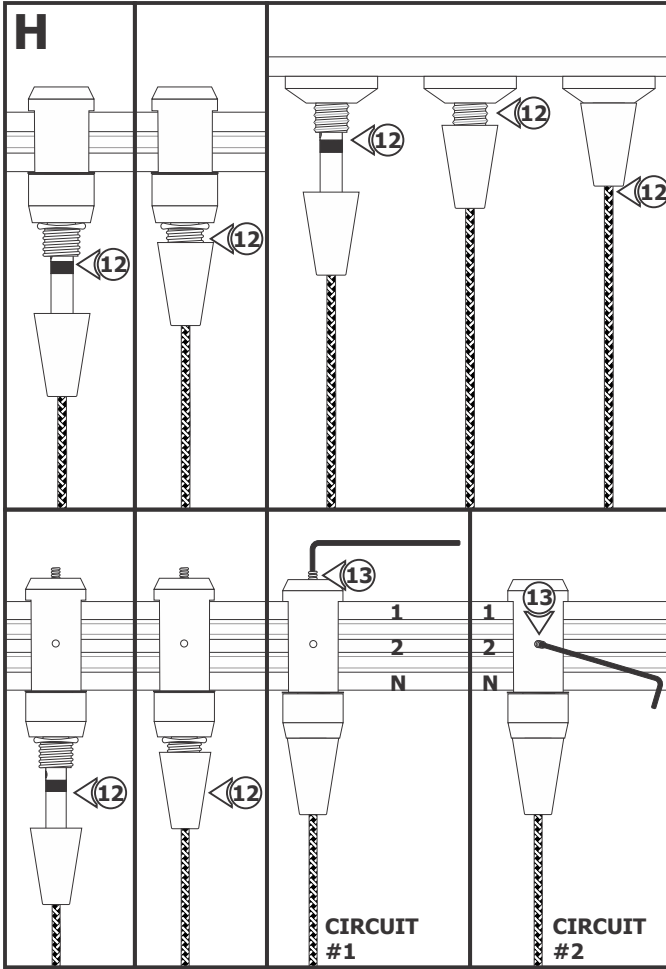

12: Use fingers to tighten the Fast Jack fixture connector into the Fast Jack system connector (Monorail, Monorail Wall, Monorail 2 Circuit, or multi-port and mono-point canopies. Refer to the instructions provided with the system connector or canopy).

13: Refer to the instructions provided with the Monorail 2 Circuit fixture connector to choose the Circuit #1 or Circuit #2.

Install the Lamp

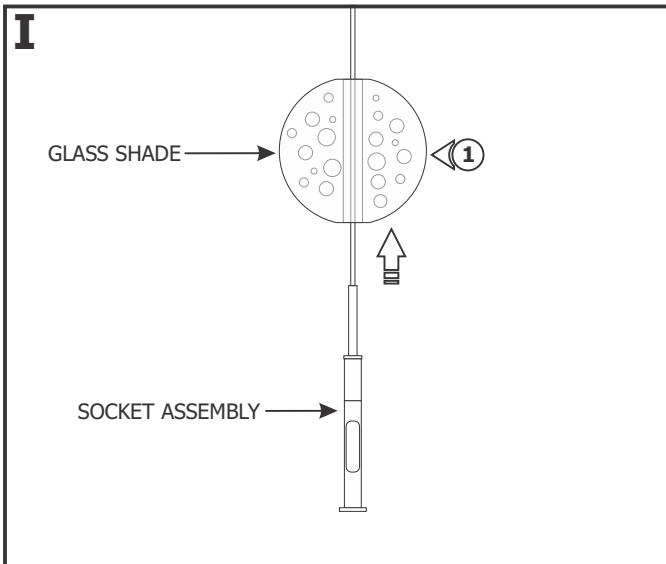

CAUTION: To reduce risk of a burn or electrical shock during lamping, disconnect the power to the fixture.

1: Lift the glass shade up to expose the socket assembly.

NOTE: Do not loosen or otherwise modify the power cable set screw. This will cause damage to the fixture.

2: Unscrew the bottom portion of the fixture to attach lamp.

3: Insert LED bulb into 2-pronged socket, and re-attach the bottom portion of the fixture.

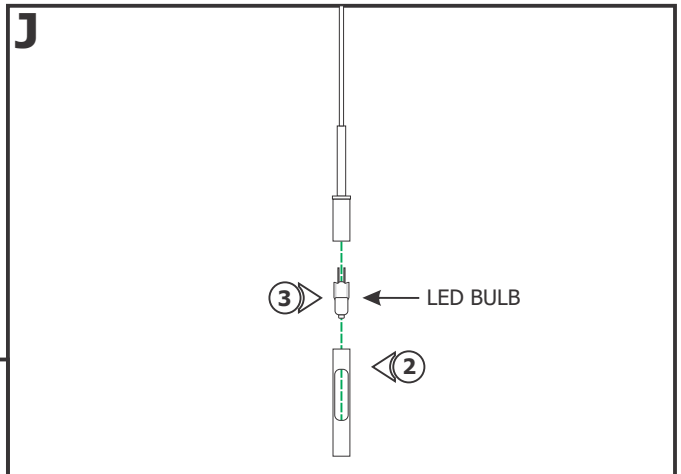

K

GLASS SHADE →

SOCKET →
LED LAMP →

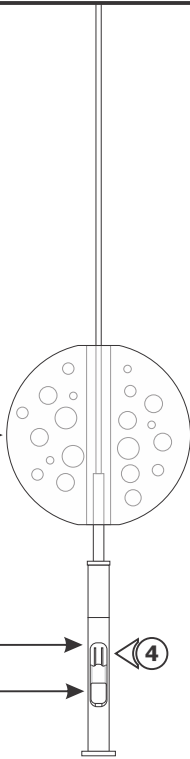

4: Push the lamp pins completely into the socket holes.

L

SOCKET →

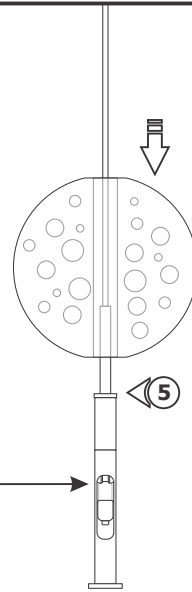

5: Carefully lower the glass shade onto the socket assembly.

NOTE: Use only a clean damp towel to clean the bubble balls. Do not use any cleaning solutions which may cause the colored bubble balls to get damaged.