



EDGE
LIGHTING

© 2017 Edge Lighting. All Rights Reserved.

1718 W. Fullerton Ave
Chicago, IL 60614
Tel: 773-770-1195
Fax: 773-935-5613
www.edgelighting.com
info@edgelighting.com

GLD_ _ _ W-E_ _ _ _ _

Installation Instructions for **Glide Downlight - End Feed**

IMPORTANT INFORMATION

- This product is ceiling-mount only.
- Care and Maintenance: To clean wood panels (if applies) dust them using a dry rag or use a very dry damp cloth with furniture cleaner.
- This product is dimmable with a single electronic low voltage dimmer.

SAVE THESE INSTRUCTIONS!



Section One: Install the Canopy

A

MOUNTING PLATE

PHILLIPS SCREW

CANOPY

①

NOTE:

Before beginning any electrical work, ensure that power to the electrical box is turned off.

1: Loosen and remove the four Phillips screws from the canopy to remove the mounting plate.

- 2:** Make sure the mounting plate is grounded in accordance with local electrical codes.
- 3:** Feed the 120VAC power wires through the mounting plate center hole.
- 4:** Secure the mounting plate to the junction box using the #8-32 screws.

B

CEILING

#8-32 SCREW

MOUNTING PLATE

②

③

④

Section Two: Install the Coaxial Cables

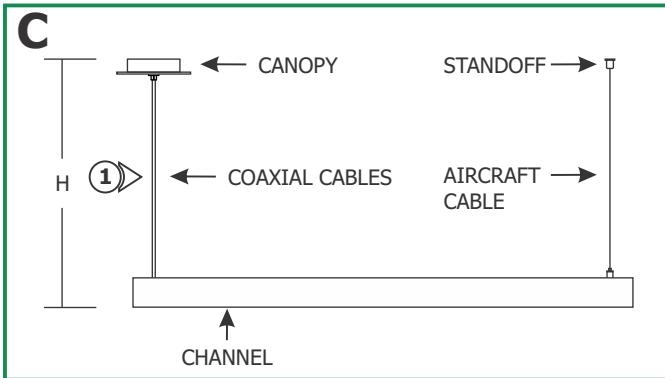

1: Determine the fixture height (H) from the bottom of the channel to the top of the canopy. Determine the fixture length (L) and mark the standoff location from the center of the electrical box.

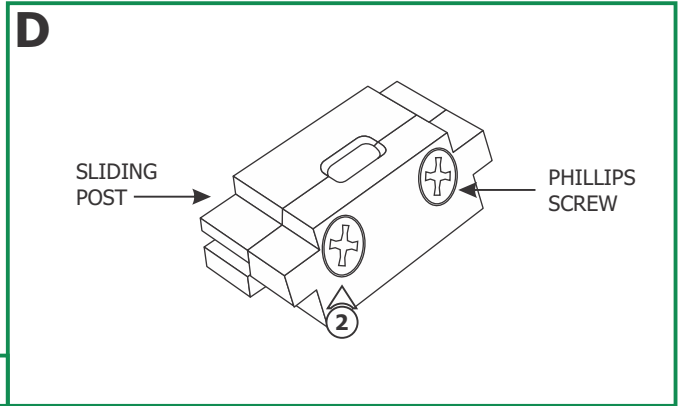
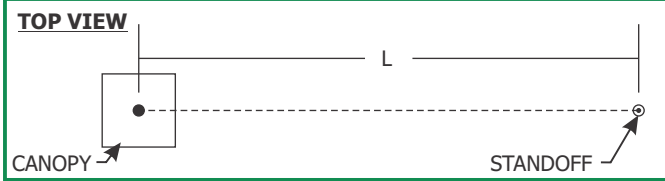

2: Remove the two Phillips screws from the sliding post.

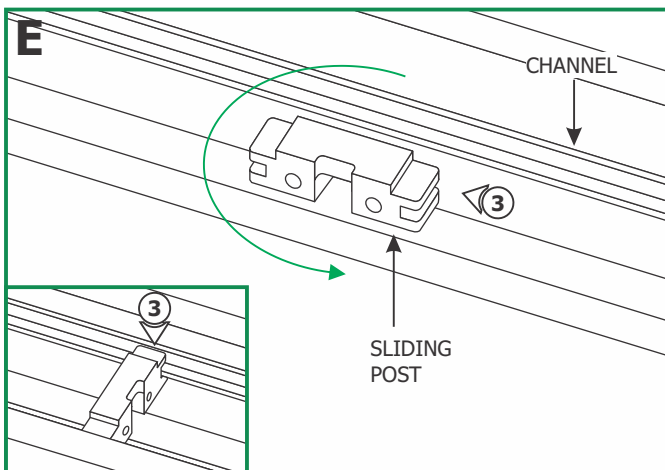

3: Place the back part of the sliding post inside the back of the channel and rotate it into place.

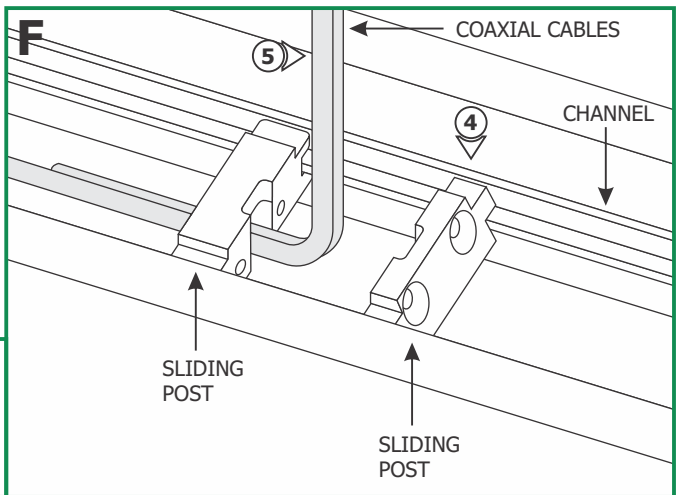

4: Place the other part of the sliding post onto the back of the channel.

5: Ensure that the coaxial cables are in between the two parts of the sliding post.

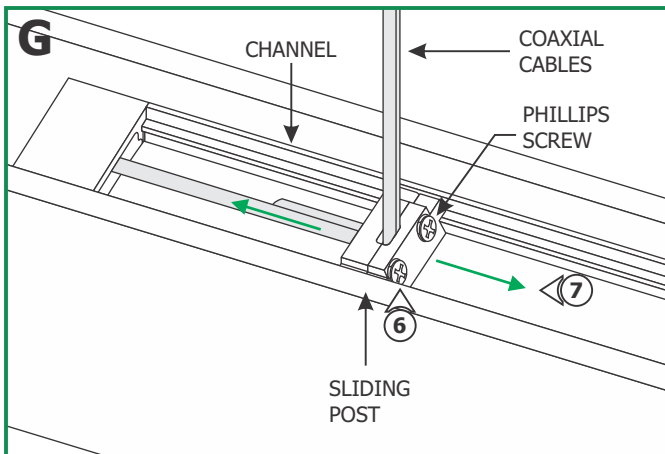

6: Insert the two Phillips screws halfway into the sliding post to loosely join the two parts.

7: Adjust the position of the sliding post by moving it across the channel.

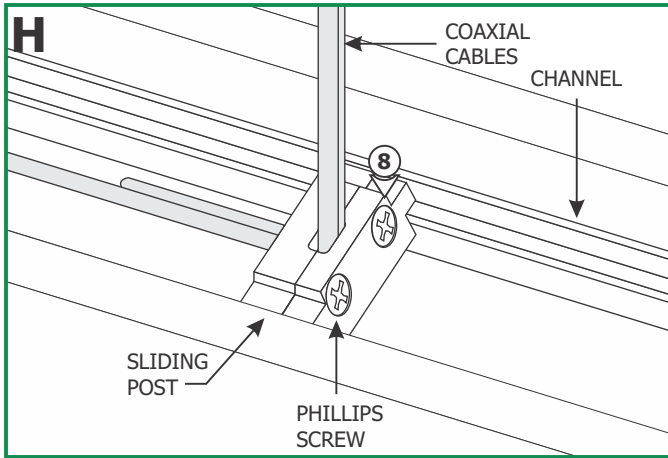

8: Tighten the two Phillips screws on the sliding post to secure it to the channel.

NOTE: If cable is curled or kinked, straighten by holding between the shaft of a screwdriver and thumb and pulling the cable through (see inset).

2: Split the end of the cable and push each coaxial cable through each tab on the cord grip of the canopy.

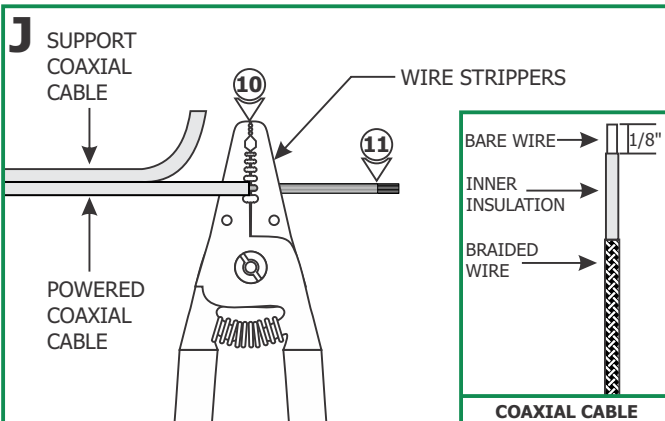
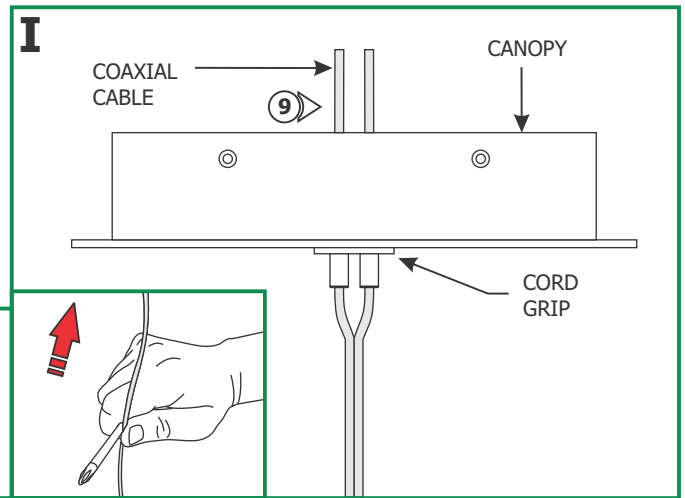

10: Using the 18 AWG hole of the wire strippers, remove 1" of the outer braided wire of the powered cable.

11: Using the 20 AWG hole of the wire strippers, remove 1/8" of inner plastic insulation from the end of the powered cable. The other cable is used as support only.

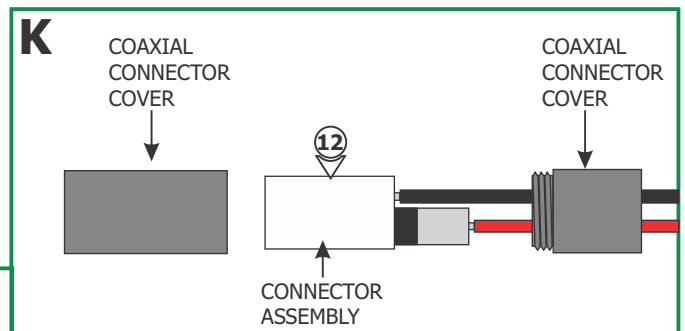

12: Unscrew the coaxial connector covers and remove from the connector assembly.

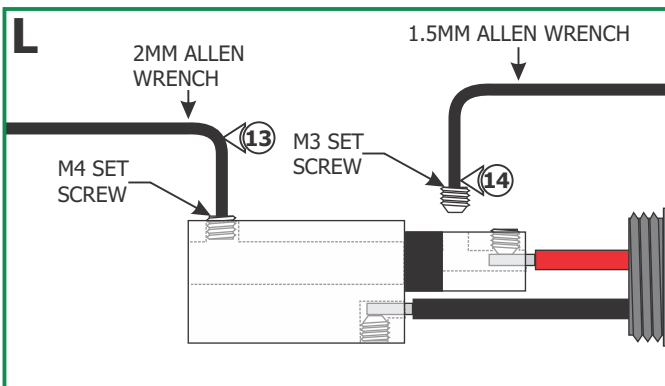

13: Using the provided 1.5mm Allen wrench, remove the M3 set screw from the coaxial connector assembly.

14: Using the provided 2mm Allen wrench to loosen (do not remove) the M4 set screw.

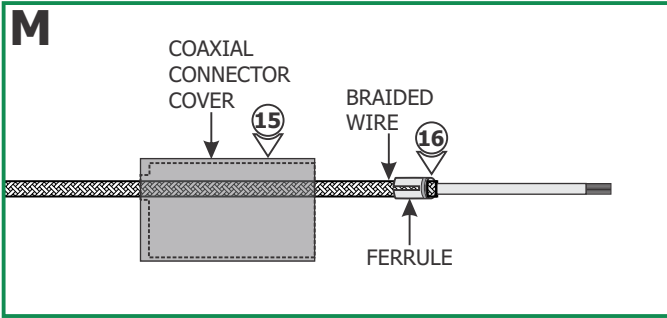

15: Slide the connector cover over the coaxial cable.

16: Place the ferrule over the braided wire of the coaxial cable.

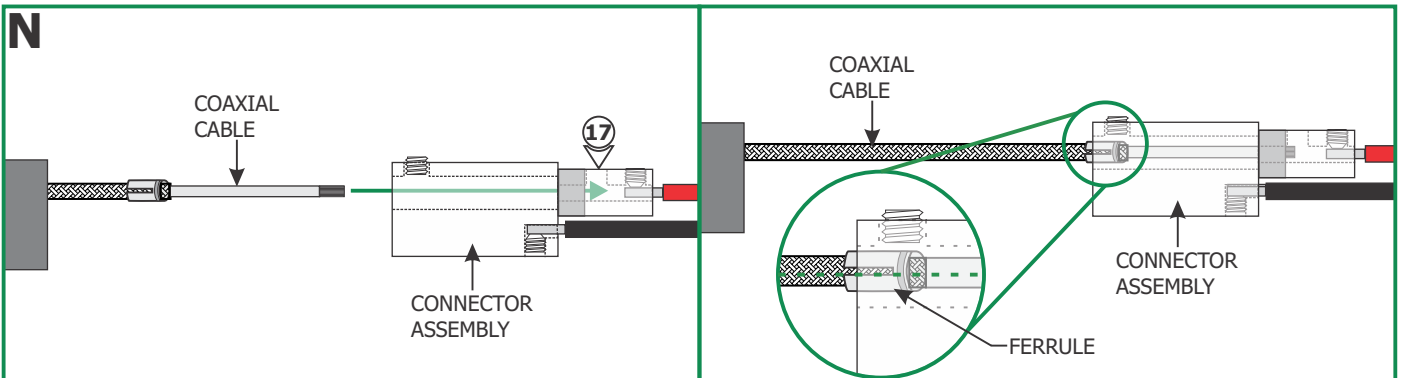

17: Insert the coaxial cable into the coaxial connector until the wires of the center conductor are visible through the M3 set screw hole.

NOTE: Ensure that the split in the ferrule is aligned 90° from the M4 set screw (see inset).

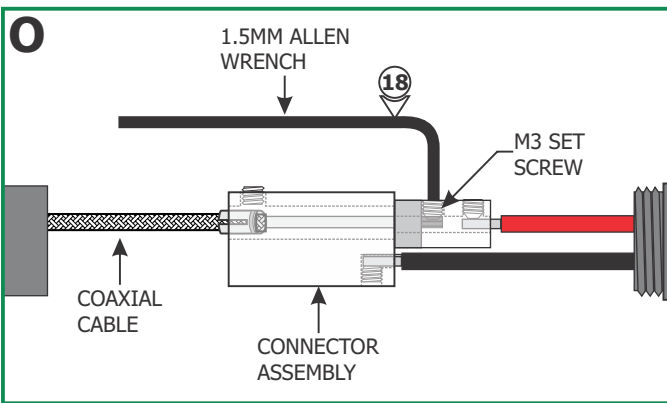

18: Use the provided 1.5mm Allen wrench to replace and securely tighten the M3 set screw.

19: Use the provided 2mm Allen wrench to securely tighten the M4 set screw until it squeezes the wire ferrule tightly to the coaxial cable.

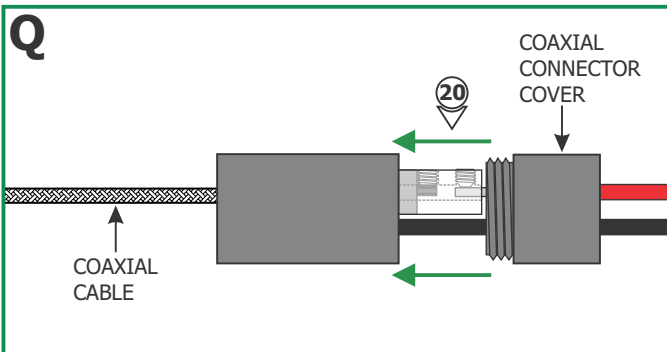
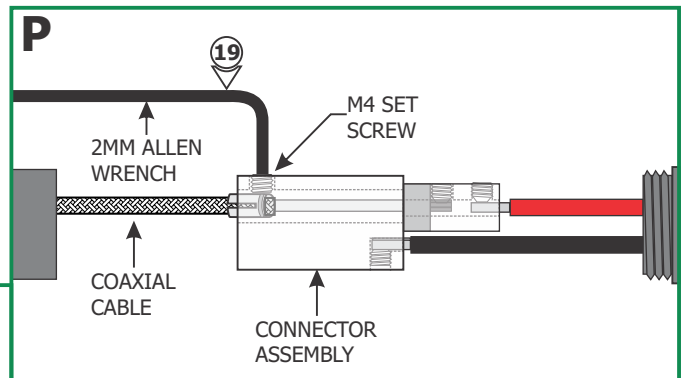

20: Replace the coaxial connector cover and tighten into place.

Section Three: Install the Standoff

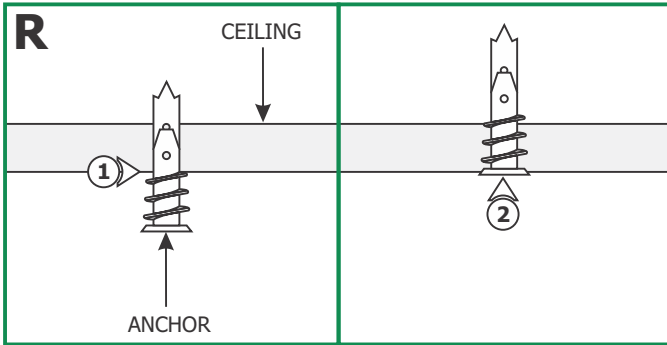

- 1:** For each provided standoff, tap the anchor onto the marked location up to the threaded portion with a hammer.
- 2:** Screw in the threaded portion of the anchors with a Phillips screwdriver.

- 3:** Feed the #8 screw through the threaded washer.
- 4:** Tighten the #8 screw completely into the anchor.
- 5:** Feed the aircraft cable through the threaded post. Tighten the threaded post completely onto the threaded washer.

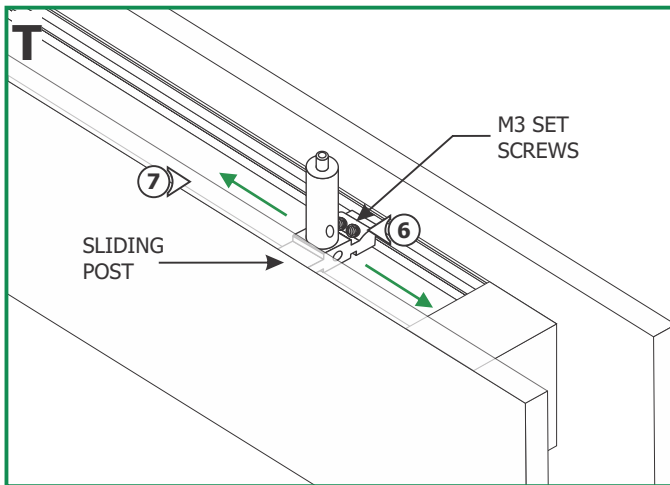
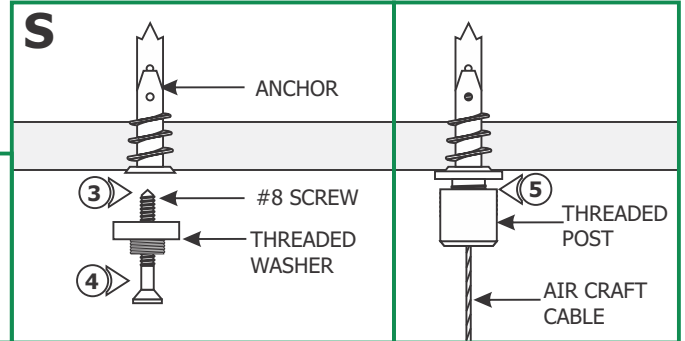

- 6:** If the fixture is provided with additional supports in the middle of the channel then loosen (**Do Not Remove**) the two M3 set screws on the sliding post with a 1.5mm Allen wrench.
- 7:** Adjust the position by moving the sliding post across the channel.

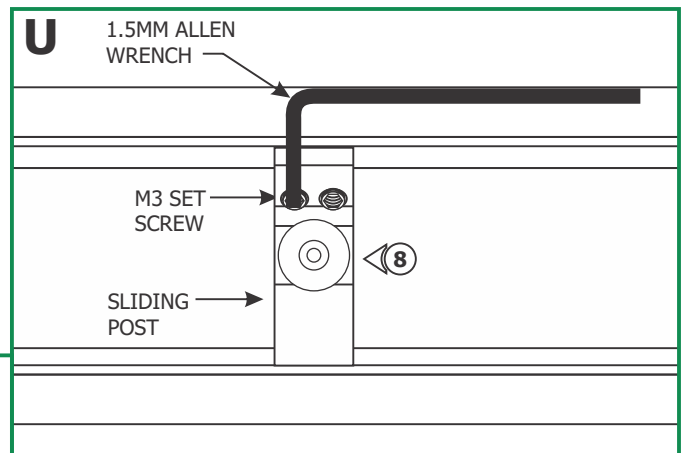

- 8:** Tighten the two M3 set screws.
- 9:** Repeat steps 6 through 8 for the remaining standoffs.

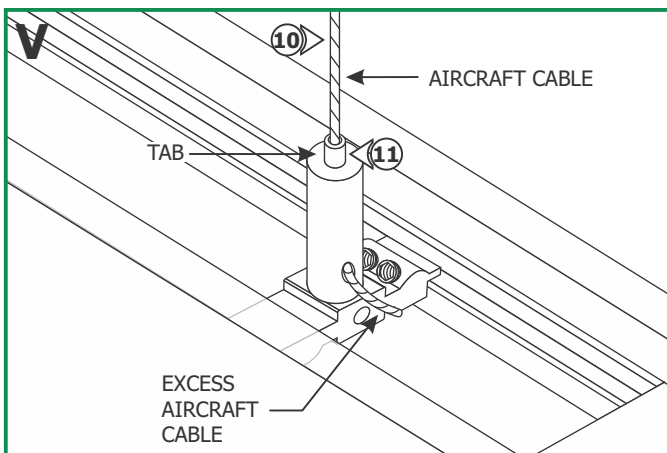

- 10:** For each standoff, insert the aircraft cable through the top of the tab on the sliding post.
- 11:** Adjust the height of the fixture by pushing the tab and pulling the aircraft cable out of the side of the sliding post. Release the tab to secure the cable in place.

Section Four: Power the Fixture

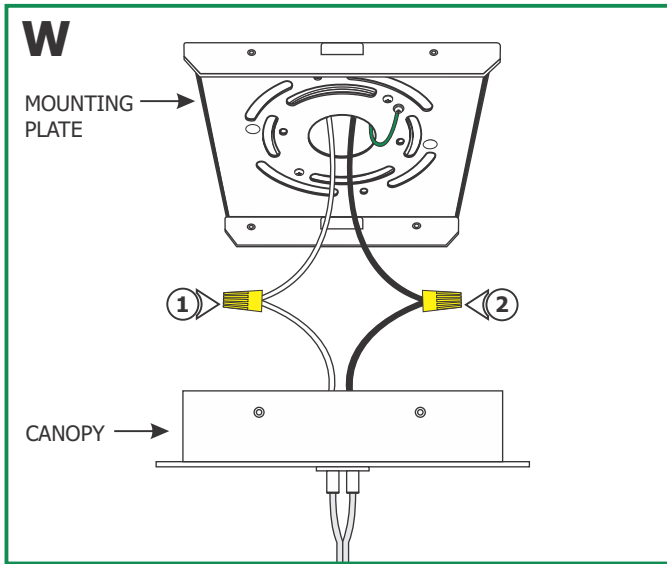

- 1:** Connect the neutral wire from the 120VAC circuit to the white wire of the power supply using a wire nut.
- 2:** Connect the hot wire from the 120VAC circuit to the black wire of the power supply using a wire nut.

- 3:** Connect the low voltage black wire from the power supply to the black wire of the coaxial connector using a wire nut.
- 4:** Connect the low voltage red wire from the power supply to the red wire of the coaxial connector using a wire nut.

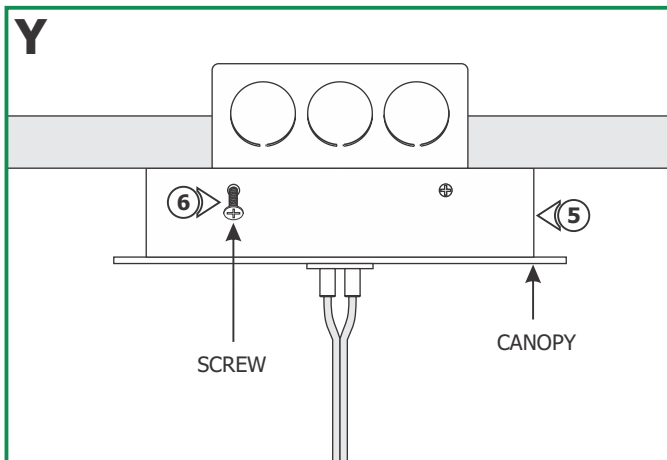
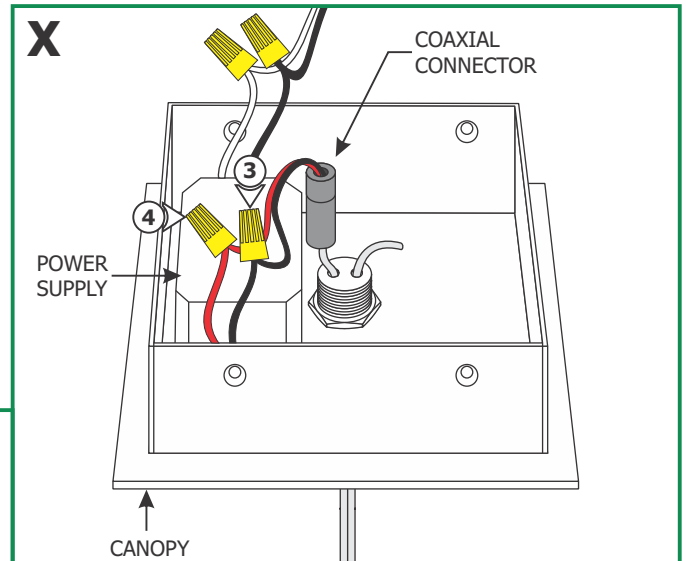

- 5:** Place all the wires and wire nut connections inside the canopy.
- 6:** Align the canopy holes and secure the canopy in place by tightening the four screws.

- 7:** For fine adjusting the fixture height, push the tab on the cord grip to slide the fixture up and down until the desired height is achieved. Release the tab to lock the coaxial cable in place.
- 8:** If necessary adjust the aircraft cable of the standoff(s) by following steps 10 and 11 using drawing V on page 5. Trim excess aircraft cable using sharp cutters.

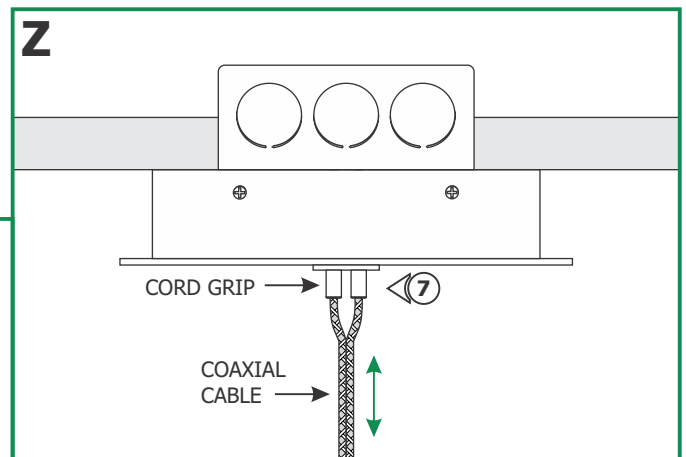

Z1

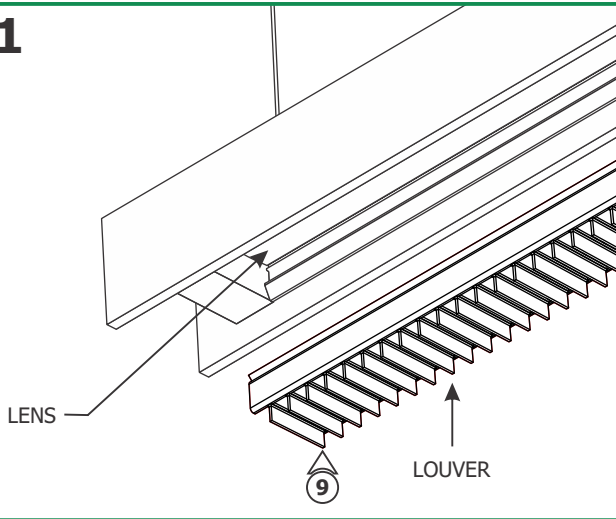

9: Install the optional louver to complete the channel assembly by pushing onto the channel over the lens.

Wiring Diagram

