



# LOW RIDER

## MONO & MULTI PORT POINT



DESIGNED BY GREGORY KAY | ASSEMBLED IN AMERICA

REV 02.08.21



**FJ-LOW-1-SN-S1-SN**  
Satin Nickel



**FJ-LOW-1-SN-S1-SN**  
Satin Nickel with  
Satin Nickel S1 Shade

### DESCRIPTION

Petite yet versatile, the classic Low Rider spotlight rotates 360° and tilts 90°. Select from a variety of shades to personalize the timeless design (Sold Separately).

### FINISH & MATERIAL

- Finished in Satin Nickel, Polished Nickel\* or Antique Bronze
- Machined from Billet Aluminum
- Tilt: 90°
- Rotation: 360°

\*Limited quantities available. Please call for more information.

### SYSTEM MOUNTING OPTIONS

For use with any 12VAC Fast Jack Port including Monorail Circuit Rail, MonoPoint canopies 2" or 4" round (**RD**), and multi-port canopies

### APPLICATION

Suitable for damp or dry location, interior use only

### LAMP SPECIFICATIONS

- LED MR16 lamp GU 5.3 base - 12 volt (sold separately) up to 490
- Lumens 2700K, 3000K, may be order in warm dim to 1800K
- Halogen lamp Max 50 watt monopoint canopy only

### POWER SUPPLY IN CANOPY

120V input-12VAC output, ELV electric low voltage power supply (FJ and M fixtures order power supply separately)

### HEIGHT

1.2" (3cm), 3" (7.6cm)

### DIMMING

- Dimmable to 1% Percent of Flicker <25%
- Triac and ELV dimming standard. Compatible with Lutron Diva, Skylark and Legrand ELV dimmers

### COMPLIANCE LABEL

ETL (Conforms to UL1598 and CSA 22.2 #250.0)

### WARRANTY

5 year warranty. See PureEdgeLighting.com

System		Fixture	Stem Height	Finish
<b>FJ</b>		<b>LOW</b>	<b>1</b>	<b>SN</b>
<b>FJ</b>	Fast Jack	<b>LOW</b>	<b>1</b> 1.2" (3cm)	<b>BZ</b> Antique Bronze
<b>M</b>	Monorail		<b>3</b> 3" (7.6cm)	<b>SN</b> Satin Nickel
<b>MP2R</b>	Mono-Point 2" Round Canopy		<b>12</b> 12" (30cm)*	<b>PN</b> Polished Nickel*
<b>MP4R</b>	Mono-Point 4" Round Canopy			
<b>MP4RS</b>	Mono-Point 4" Round Surface Mount			
<b>2P4R</b>	2 port 4" Round Canopy			
<b>3P8R</b>	3 Port 8" Round Canopy			
<b>3P12R</b>	3 Port 12" Round Canopy			
<b>2P12RE</b>	2 Port 12" Rectangle Canopy			
<b>3P12RE</b>	3 Port 12" Rectangle Canopy			

\*Limited quantities available. Please call for more information.

PROJECT	FIXTURE TYPE	DATE
---------	--------------	------

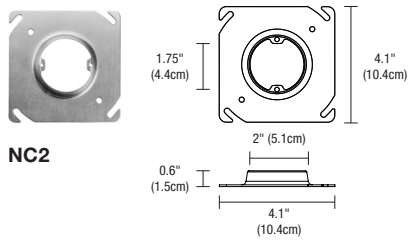

**NC2**

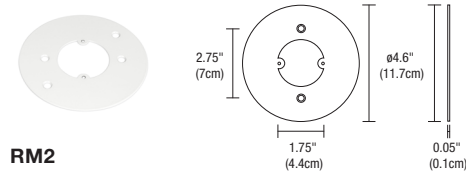

**RM2**

**NEW CONSTRUCTION & REMODEL 2" COVER FOR 4" SQUARE JUNCTION BOX**

NC2 included with the 2" Round Canopies. NC2 New Construction Junction Box Cover mounts to a standard 4" Electrical Box or Octagon Box, converting it to a 2" Plaster Ring for a 2" Round or Square Canopy. The RM2-Jbox Remodel Plaster Plate cover is used with the existing 4" Square Junction Box and Round Plaster Ring.

System	Type
<b>NC2</b>	<b>JBOX</b>
NC2 New Construction 2"	JBOX Junction Box Cover
RM2 Remodel Plaster Plate	

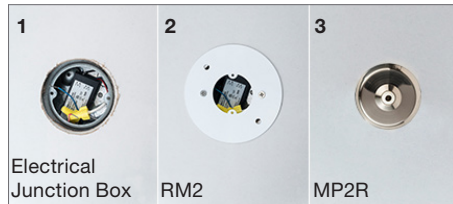

- Existing 4SQ J-box with Round Plaster Ring
- Add RM2 Remodel Plate with Power Supply from MP2R fixture
- Plaster and paint ceiling, then add Canopy and fixture

**FAST JACK (CONNECTOR ONLY)**



**FJ-LOW-1-SN-S1-SN**

Low Rider with Fast Jack

Shown in Satin Nickel, Shade Sold Separately

**MONORAIL (CONNECTOR INCLUDED)**



**M-LOW-3-SN-S1-SN**

Monorail (M) with Low Rider

Shown in Satin Nickel, Shade Sold Separately

**MONOPOINT 2" ROUND FLAT CANOPY**



**MP2R-LOW-1-SN-S1-SN**

Mono-Point 2" Round Canopy with Low Rider

Shown in Satin Nickel, Shade Sold Separately

**MONOPOINT 4" ROUND FLAT CANOPY**



**MP4R-LOW-1-SN-S1-SN**

Mono-Point 4" Round Canopy with Low Rider

Shown in Satin Nickel, Shade Sold Separately

**MONOPOINT 4" ROUND SURFACE CANOPY**



**MP4RS-LOW-1-SN-S1-SN**

1" Stem, 3000K

Shown in Satin Nickel, Shade Sold Separately

**MULTIPOINT 2-PORT, 4" ROUND CANOPY**



**2P4R-LOW-1-SN-S1-SN**

2-Port 4" Round Canopy with Low Rider  
Shown in Satin Nickel, Shade Sold Separately

**MULTIPOINT, 3-PORT 8" ROUND CANOPY**



**3P8R-LOW-1-SN-S1-SN**

3-Port 8" Round Canopy with Low Rider  
Shown in Satin Nickel, Shade Sold Separately

**MULTIPOINT, 3-PORT 12" ROUND CANOPY**



**3P12R-LOW-1-SN-S1-SN**

3-Port 12" Round Canopy with Low Rider  
Shown in Satin Nickel, Shade Sold Separately

**MULTIPOINT, 2-PORT 12" RECTANGLE CANOPY**



**2P12RE-LOW-1-SN-S1-SN**

2-Port 12" Rectangle Canopy with Low Rider  
Shown in Satin Nickel, Shade Sold Separately

**MULTIPOINT, 3-PORT 12" RECTANGLE CANOPY**



**3P12RE-LOW-1-SN-S1-SN**

3-Port 12" Rectangle Canopy with Low Rider  
Shown in Satin Nickel, Shade Sold Separately

PROJECT		FIXTURE TYPE		DATE	
---------	--	--------------	--	------	--

### CANOPY DIAGRAMS: Canopy diagrams and measurements for Low Rider LED

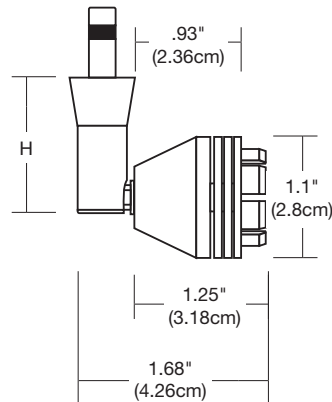
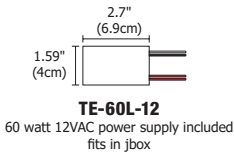
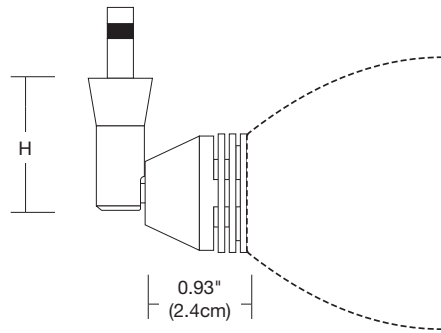
**FJ-LOW**

**TE-60L-12**

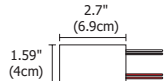
60 watt 12VAC power supply included fits in jbox

**TE-60L-12**

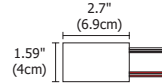
60 watt 12VAC power supply included fits in jbox

**TE-60L-12**

60 watt 12VAC power supply included fits in jbox

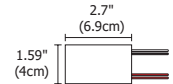
**TE-60L-12**

60 watt 12VAC power supply included fits in canopy

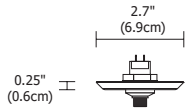
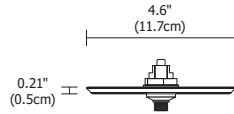
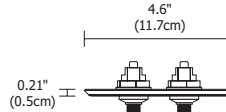
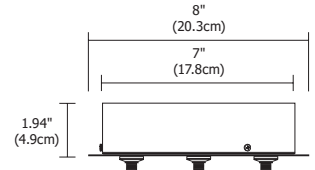
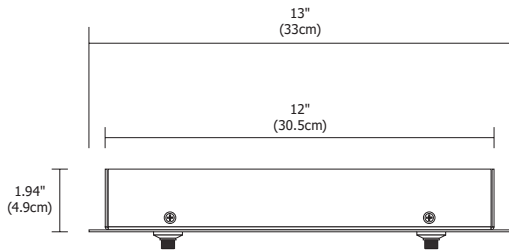
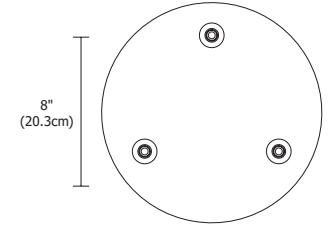
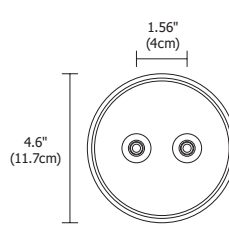
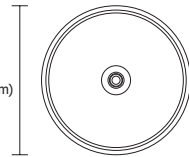
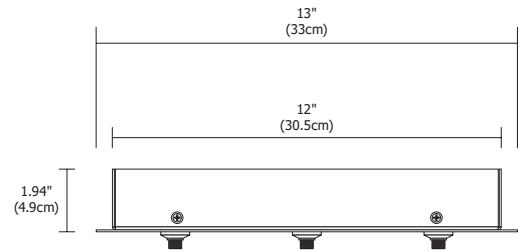
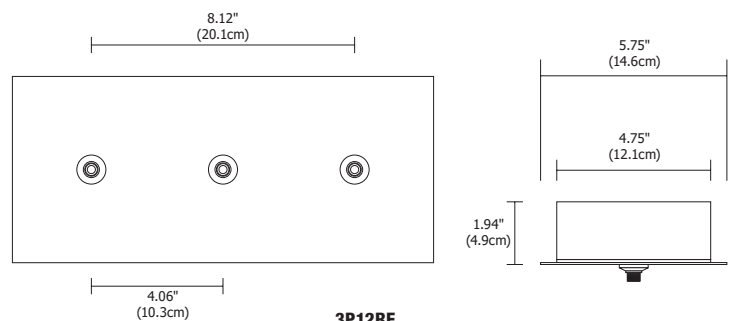
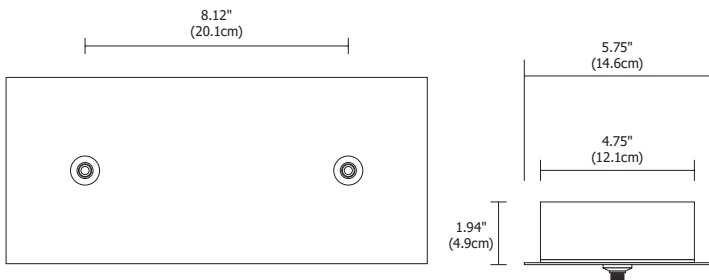
**MP2R**

**MP4R**

**2P4R**

**3P8R**

**2P12RE**

**3P12RE**

PROJECT	FIXTURE TYPE	DATE
---------	--------------	------



**LOW RIDER**  
MONO & MULTI PORT POINT



**S1 LITTLE SHADE**

Small, Solid Metal Shade fits on Low Rider or Vespa and holds a Single Lens or Louver using a Snap Louver Lens Holder (included), up to 50 watt MR16

Accessory	Finish
<b>S1</b>	<b>SN</b>
<b>S1</b> Little Shade	<b>SN</b> Satin Nickel



**S2 LITTLE MESH SHADE**

Small, Mesh Metal Shade fits on Low Rider or Vespa and holds a Single Lens or Louver using a Snap Louver Lens Holder (included). Low Rider becomes LED compatible using the S2 shade with an LED MR16 Lamp, up to 50 watt MR16.

Accessory	Finish
<b>S2</b>	<b>BZ</b>
<b>S2</b> Little Mesh Shade Limited quantities available. Please call for more information.	<b>BK</b> Black <b>BZ</b> Antique Bronze



**S5 GLASS SHADE**

Big, Solid Metal Shade fits on Low Rider and holds a Single Lens or Louver using a Snap Louver Lens Holder (included), up to 50 watt MR16.

Accessory	Finish
<b>S5</b>	<b>SN</b>
<b>S5</b> Big Shade Limited quantities available. Please call for more information.	<b>BZ</b> Antique Bronze <b>PN</b> Polished Nickel <b>SN</b> Satin Nickel



**MR16 LOUVER LENS HOLDER**

MR16 Louver Lens Holders secure onto front of the MR16 lamp holding up two Lenses or combination of a Hexcell Louver and Lens.

Accessory	Finish
<b>LH16</b>	<b>SN</b>
<b>LH16</b> Lens Holder MR16 Limited quantities available. Please call for more information.	<b>BK</b> Black <b>BZ</b> Antique Bronze <b>SN</b> Satin Nickel



ST16-SN

STB16-BK

**SNOOT**

The Snoot prevents glare and focuses the projected light from the lamp. The MR16 Snoot requires a Louver Lens Holder (sold separately) when used with Low Rider, Low Rider Spinner, Chopper and Vespa.

Accessory	Finish
<b>ST16</b>	<b>SN</b>
<b>ST16</b> Snoot MR16 <b>STB16</b> Snoot MR16 (Black Only) Limited quantities available. Please call for more information.	<b>BZ</b> Antique Bronze <b>SN</b> Satin Nickel

PROJECT	FIXTURE TYPE	DATE
---------	--------------	------

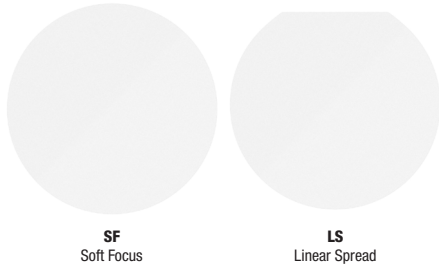

**FILM LENS SOFT FOCUS**

SF Soft Focus diffuses a beam pattern to provide even illumination. LS Linear spread lens directs the 10°, 15°, 25° beam into an elongated shape. This is typically used in long rectangle paintings and art work, 35°, 40°, 60° lamps produce an elongated oval shape used in art work and wall wash.

Film Size	Film Type
<b>LF2</b>	<b>SF</b>
<b>LF2</b> 2.0" Film Limited quantities available. Please call for more information.	<b>SF</b> Soft Focus <b>LS</b> Linear Spread

**2" ROUND GLASS OPTICAL LENS**

The soft focus lens reduces lamp glare, spread lenses elongate and diffuser lenses diffuse the light beam. UV filter lens allows quality light to pass through while blocking the ultraviolet radiation.

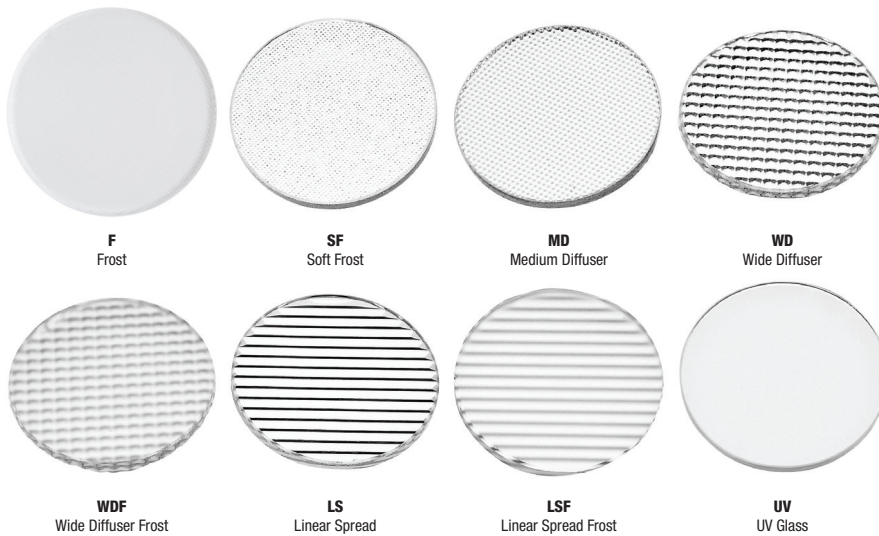

Lens	Optical Type
<b>L16</b>	<b>SF</b>
<b>L16</b> MR16 Lens	<b>F</b> Frost <b>SF</b> Soft Focus <b>MD</b> Medium Diffuser <b>WD</b> Wide Diffuser <b>WDF</b> Wide Diffuser Frost <b>LS</b> Linear Spread <b>LSF</b> Linear Spread Frost <b>UV</b> UV Glass
Limited quantities available. Please call for more information.	



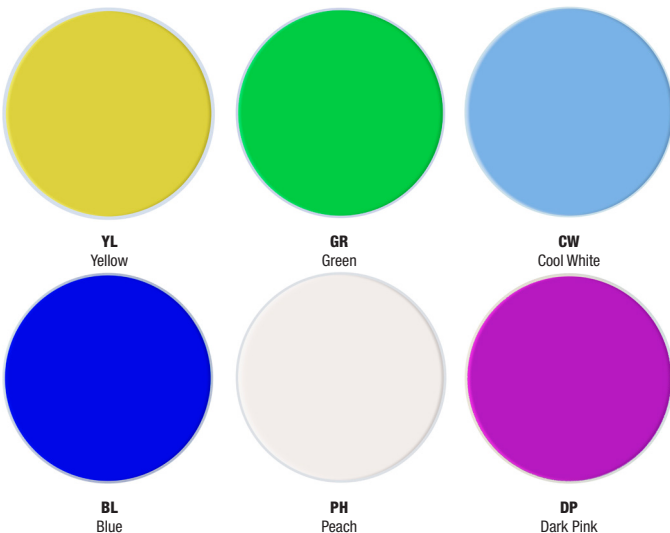

**2" ROUND DICHROIC GLASS LENS**





Dichroic lenses operate on a passive-reflective basis, reflecting unused wavelengths while passing wanted portions of spectrum. Dichroics are high in transmission, producing brighter, cleaner, saturated colors.



Lens	Dichroic Color
<b>L16</b>	<b>RD</b>
<b>L16</b> MR16 Lens	<b>YL</b> Yellow* <b>GR</b> Green <b>CW</b> Cool White (3100K-4250K)* <b>BL</b> Blue <b>PH</b> Peach* <b>DP</b> Dark Pink* *Limited quantities available. Please call for more information.

PROJECT	FIXTURE TYPE	DATE
---------	--------------	------

2700K MR16 12V LED LAMPS					
BRAND	SORAA			SOL-Light	
					
ORDERING CODE	SM16-07-100-927-03	SM16-09-25D-927-03	SM16-09-36D-927-03	MR16-12V-9W-NF-27KWID-SL	MR16-12V-9W-FL-27KWID-SL
CRI	95	95	95	97	97
BEAM ANGLE (DEGREES)	10	25	36	24	36
TOTAL LUMENS	390	465	465	468	450
LUMENS PER WATT	52	52	52	50	55
HALOGEN EQUIVALENT	50	60	60	50	50

3000K MR16 12V LED LAMPS					
BRAND	SORAA			SOL-Light	
					
ORDERING CODE	SM16-07-100-930-03	SM16-09-25D-930-03	SM16-09-36D-930-03	MR16-12V-9W-NF-30KWID-SL	MR16-12V-9W-FL-30KWID-SL
CRI	95	95	95	97	97
BEAM ANGLE (DEGREES)	10	25	36	24	36
TOTAL LUMENS	410	490	490	468	450
LUMENS PER WATT	55	54	54	53	58
HALOGEN EQUIVALENT	50	60	60	50	50

**SORAA VIVID MR16 36° FL**

**3000K** | Rf: 90.4 | Rg: 99.5

Color Vector Graphic

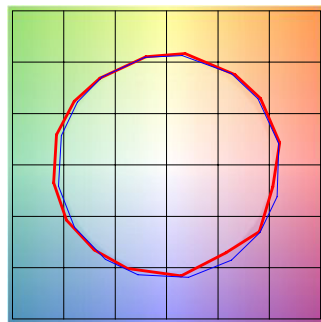

■ Test ■ Reference

GRAPHIC SHIFTS %			
HUE BIN	Rf	CHROMA	HUE
1	94.4	1.0%	0.8%
2	94.6	2.1%	-1.1%
3	91.9	1.1%	-3.3%
4	91.9	2.1%	-2.1%
5	93.9	0.4%	-0.9%
6	95.2	0%	1.9%
7	93.4	2.7%	-0.7%
8	92.7	4.2%	0.1%
9	90.5	3.6%	-3.9%
10	84.3	2.3%	-9.2%
11	81.3	2.3%	-12.7%
12	81.3	-3.6%	-10.3%
13	90.5	-2.5%	-6.2%
14	88.5	-8.2%	-0.4%
15	96.2	-1.0%	0.3%
16	86.6	-5.4%	8.2%

**SOL-LIGHT WARM DIM MR16 36° FL**

**3000K** | Rf: 94.2 | Rg: 101.2

Color Vector Graphic

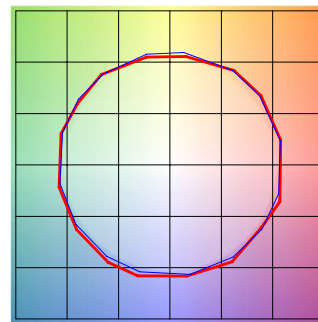

■ Test ■ Reference

GRAPHIC SHIFTS %			
HUE BIN	Rf	CHROMA	HUE
1	96.0	0.3%	0.7%
2	96.8	0.9%	-0.8%
3	95.6	0.5%	-0.8%
4	93.1	-3.2%	-2.7%
5	95.7	-2.4%	0.4%
6	96.8	0.4%	1.6%
7	92.4	-1.4%	3.5%
8	96.8	1.2%	1.2%
9	94.0	1.4%	3.1%
10	92.6	2.1%	3.9%
11	92.2	3.7%	3.9%
12	92.4	3.9%	-0.9%
13	94.7	0.9%	-3.3%
14	93.4	3.0%	-3.2%
15	93.6	-1.1%	0.9%
16	90.2	2.4%	-6.7%

**SORAA VIVID MR16 25° NFL**

**3000K** | Rf: 94.0 | Rg: 101.0

Color Vector Graphic

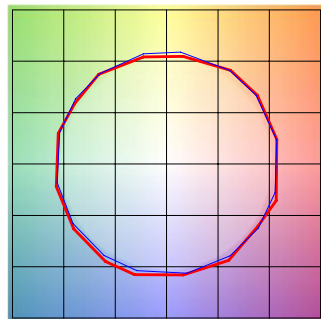

■ Test ■ Reference

GRAPHIC SHIFTS %			
HUE BIN	Rf	CHROMA	HUE
1	95.9	0.3%	0.8%
2	96.8	0.8%	-0.9%
3	95.5	0.4%	-0.9%
4	92.7	-3.4%	-2.9%
5	95.6	-2.7%	0.4%
6	96.8	0.1%	1.6%
7	92.2	-1.6%	3.7%
8	96.6	1.1%	1.5%
9	93.7	1.4%	3.3%
10	92.4	2.2%	4.1%
11	92.2	3.8%	3.8%
12	92.4	3.9%	-1.1%
13	94.4	0.8%	-3.6%
14	93.3	2.8%	-3.4%
15	93.4	-1.4%	0.9%
16	90.3	2.2%	-6.7%

**SOL-LIGHT WARM DIM MR16 24° NFL**

**3000K** | Rf: 94.2 | Rg: 101.2

Color Vector Graphic

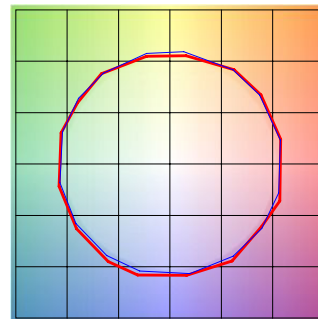

■ Test ■ Reference

GRAPHIC SHIFTS %			
HUE BIN	Rf	CHROMA	HUE
1	95.9	0.3%	0.8%
2	96.8	0.8%	-0.9%
3	95.5	0.4%	-0.9%
4	92.7	-3.4%	-2.9%
5	95.6	-2.7%	0.4%
6	96.8	0.1%	1.6%
7	92.2	-1.6%	3.7%
8	96.6	1.1%	1.5%
9	93.7	1.4%	3.3%
10	92.4	2.2%	4.1%
11	92.2	3.8%	3.8%
12	92.4	3.9%	-1.1%
13	94.4	0.8%	-3.6%
14	93.3	2.8%	-3.4%
15	93.4	-1.4%	0.9%
16	90.3	2.2%	-6.7%

PROJECT	FIXTURE TYPE	DATE
---------	--------------	------