



1718 W. Fullerton Chicago, IL 60614
 Ph: 773.770.1195 • Fax: 773.935.5613
 www.PureEdgeLighting.com • info@PureEdgeLighting.com
 © 2016 PureEdge Lighting. All Rights Reserved.

Installation Instructions for TruTrack Center Power Feed

TR24-1C-CP

IMPORTANT INFORMATION

- This product is for indoor locations only.
- This instructions shows a typical installation.
- Before beginning any electrical work, ensure that the power to the electrical box is off.

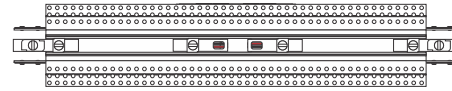
SAVE THESE INSTRUCTIONS!

Section One: Install the Junction Box

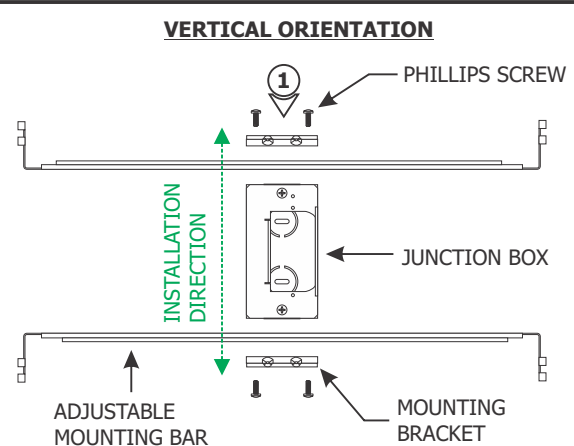
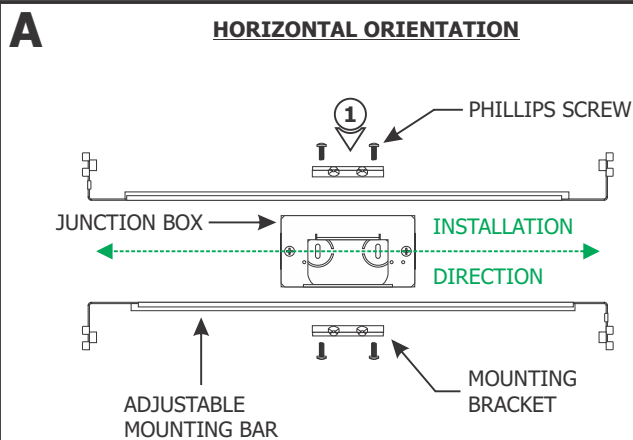

- 1:** Mount each adjustable mounting bar to one side of the junction box and secure them with the mounting brackets and Phillips screws provided.

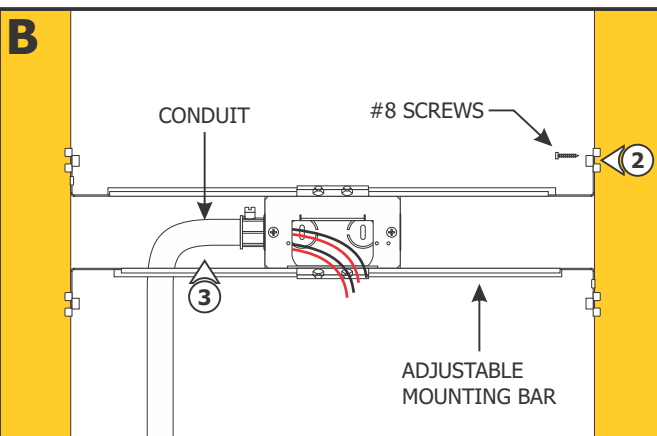

NOTE: Adjustable mounting bars mount to studs that are spaced 15" to 24" apart. If the span needs to be shorter than 15", then break the bar arms from dedicated lines.

- 2:** Place the adjustable mounting bar tabs against the ceiling joists. Secure the adjustable bars to the joists with the #8 screws.

- 3:** Install conduit (if required by local electrical code) and run the 24VDC low voltage wires coming from the remote power supplies to the junction box.

NOTE: Only use 0-10V and Uni power supplies with this product. See the wiring diagram provided with the power supply instructions.

Section Two: Install Center Power Feed

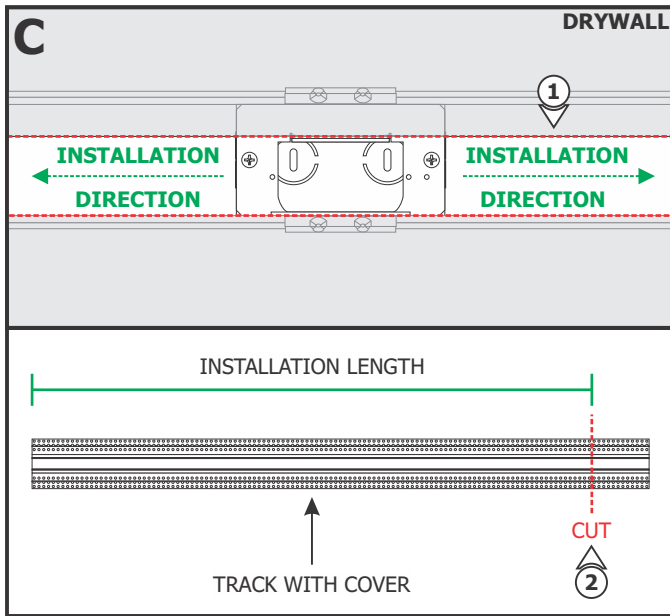

1: Cut a section of drywall to expose the junction box area. Install the drywall.

2: Mark and cut out the area where the installation will be located using the junction box opening as a guide.

NOTE: Refer to the TruTrack Recessed Channel instructions to measure and cut the track and cover before continuing.

3: Align and slide tracks over the straight connectors (T24-SC) on the ends of the Center Power Feed. Tighten the set screws using an Allen wrench and the slotted screw on the straight connector using a flat-head screw driver.

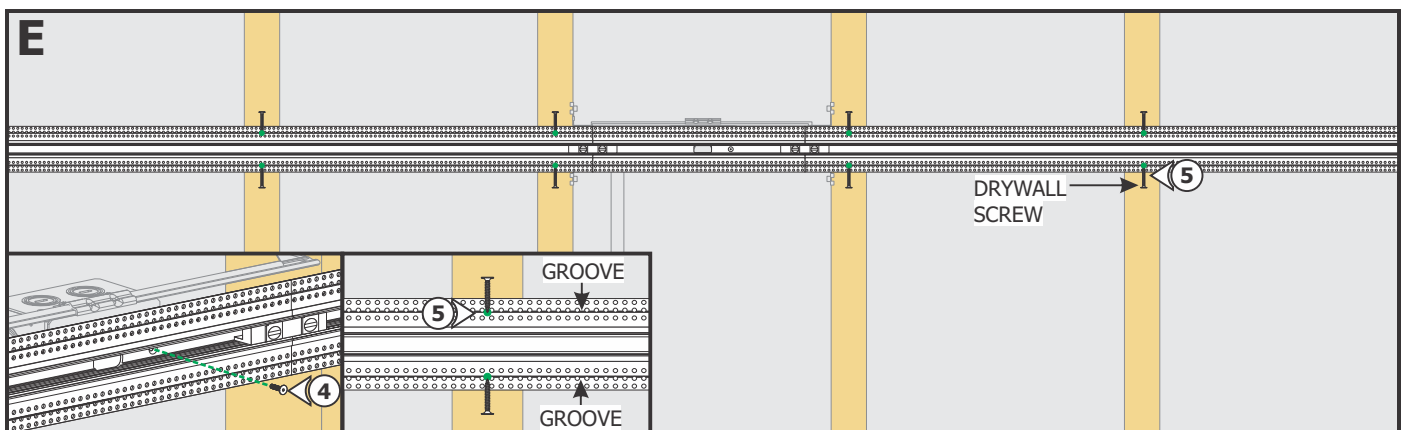
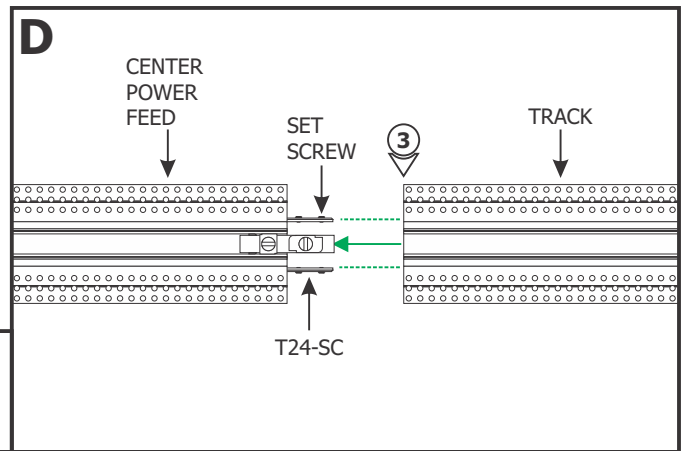

4: Secure the Center Power Feed to the junction box with the #4-40 screw using a 1/16" Allen wrench.

5: Add screws along the groove lines of each track to secure the tracks in place.

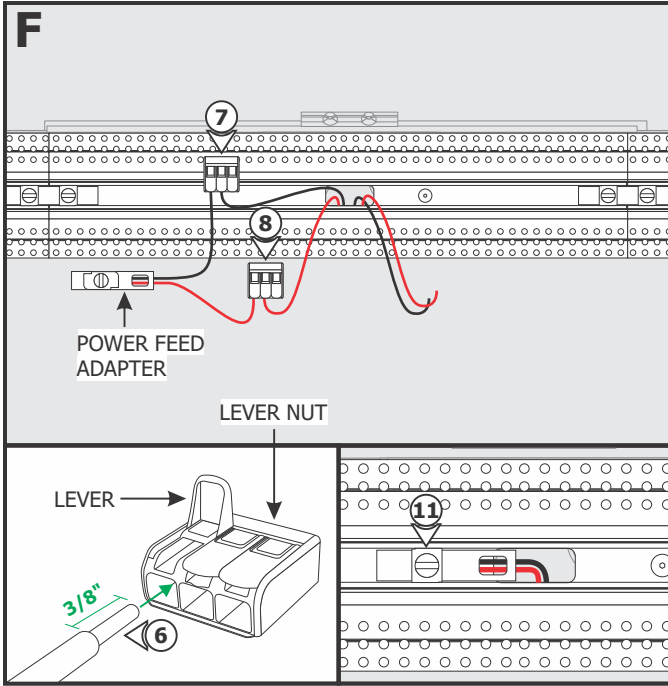

6: Strip 3/8" off of the Power Feed Adapter wires and the low voltage power supply wires.

7: Pull up the levers of one lever nut and insert the low voltage +24VDC power supply wire and the red wire of the Power Feed Adapter into the lever nut. Push the lever down to connect and lock into place.

8: Pull up the levers of the other lever nut and insert the low voltage -24VDC power supply wire and the black wire of the Power Feed Adapter into the lever nut. Push the lever down to connect and lock into place.

9: Lightly tug on the wires to ensure they are secured in place.

10: Place the lever nut connections inside the junction box.

11: Place the Power Feed Adapter inside the Center Power Feed and tighten the slotted screw with a flat-head screw driver to secure in place.

12: Repeat steps 6 through 11 for the other Power Feed Adapter and power supply.

NOTE: Refer to the TruTrack Recessed Channel instructions to plaster and complete the installation.

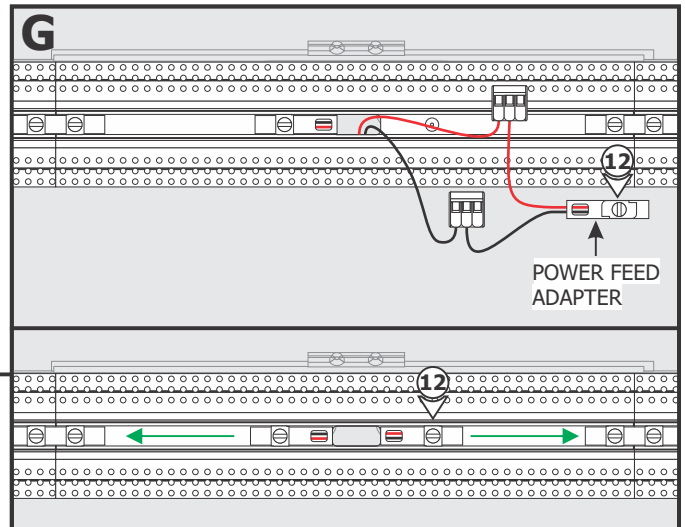

General Wiring Diagrams

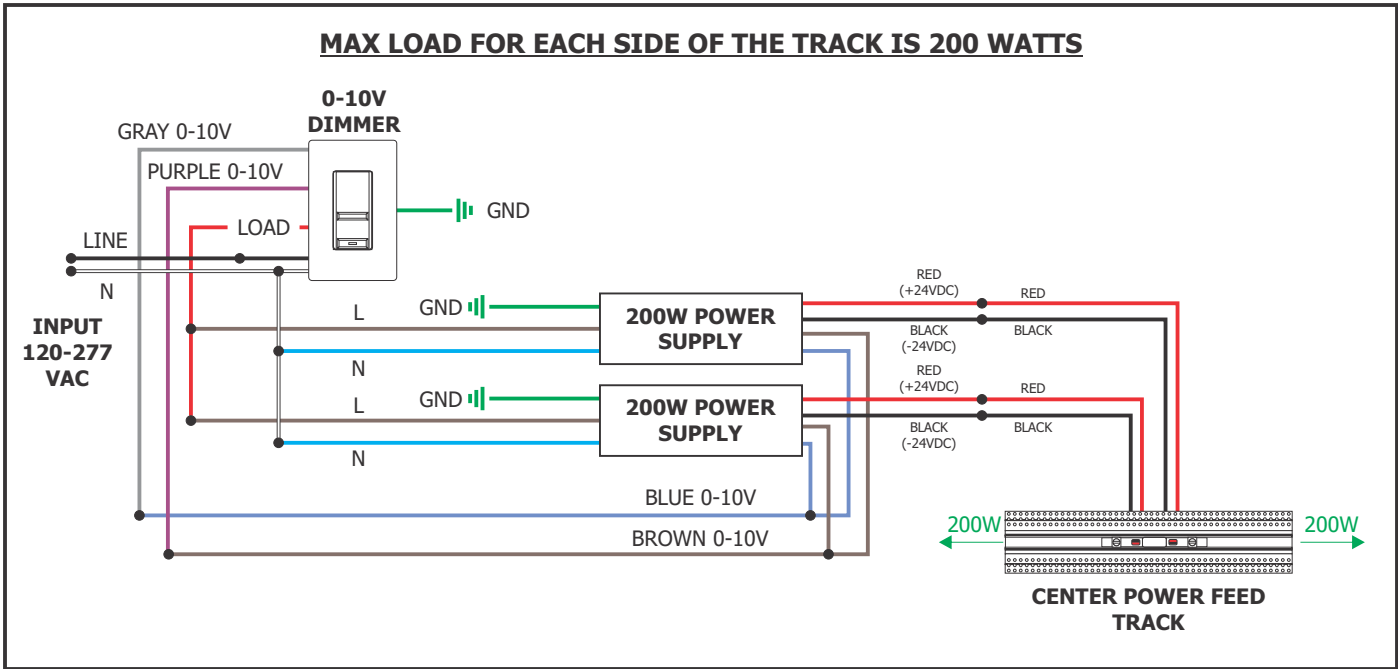
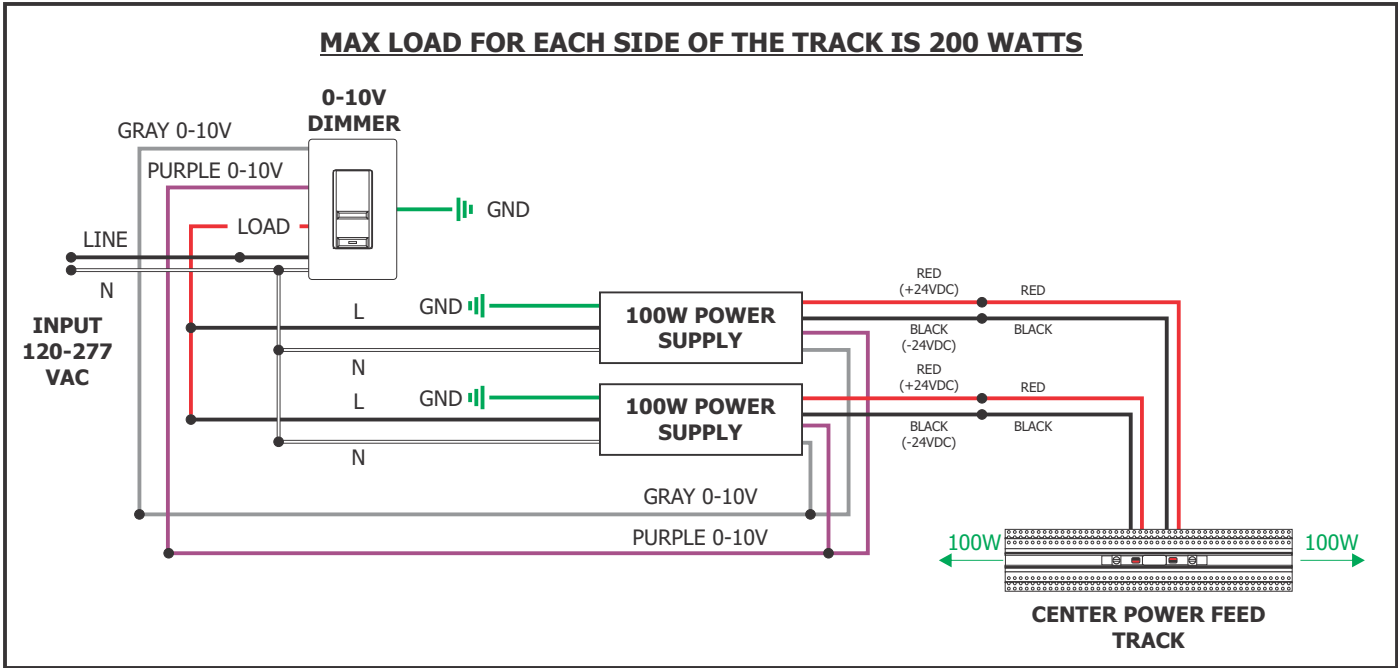

SINGLE MAX LOAD FOR BOTH SIDES OF THE TRACK IS 200 WATTS

